

PI3DPX1207B1

DP-Alt DP1.4/USB3.1 10Gbps Linear Redriver with Non-Blocking, Latency-Free and Built-in Aux Switch

Features

- DP-Alt 4-channel Redriver and DeMux (DP 2-ch and USB 2-ch)
- Latency-free USB Read/Write Transfer rate and DisplayPort Redriver Link Training for variable video frame rate control
- DP1.4 (8.1 Gbps) and USB3.1 Gen 2 (10 Gbps) standard compliant
- Type-C DP/USB mode selection: DP only, USB only, DP/USB split modes
- Natively support Transparent DisplayPort Link training with Non-blocking No-latency Linear ReDriver
- Independently controlled EQ/Gain/Swing signal outputs for DisplayPort and USB modes
- Type-C Plug and Aux Flipping controls through I2C slave pins
- Slave I2C support only. I2C speed up to 1MHz
- Auto power saving circuit
- Single Power Supply: 3.3V
- Totally Lead-Free & Fully RoHS Compliant (Notes 1 & 2)
- Halogen and Antimony Free. "Green" Device (Note 3)
- Packaging (Pb-free & Green):
 - 42-Contact, 3.5x9mm, ZH (TQFN)

Block Diagram

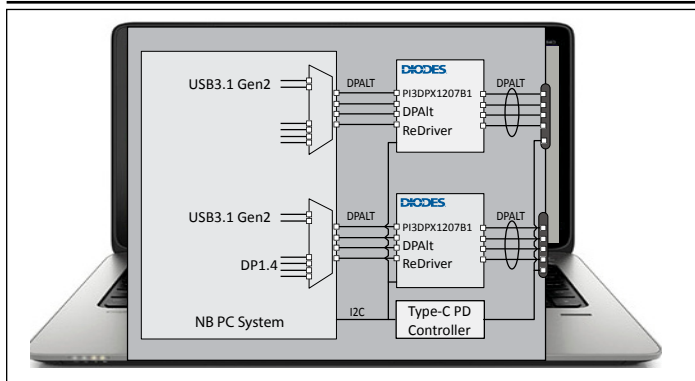

Figure 1. Type-C Connector Inside PCs

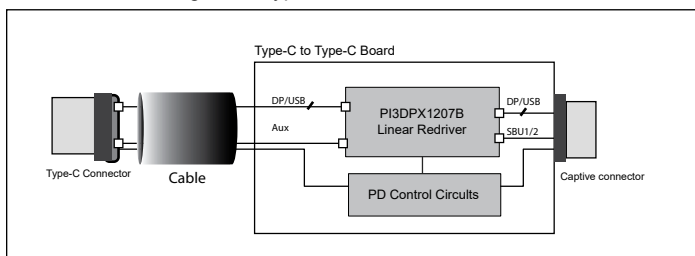

Figure 2. DP-Alt to DP Active Cables

ReDriver is a trademark of Diodes Incorporated.

Description

PI3DPX1207B1 is the DP-Alt 1.4 (Max 10Gbps) Linear Redriver™. DP1.4 standard can support 4K2K@120Hz / 25.82 Gbps with 4-channels.

Each of the DP1.4 and USB3.1 Gen2 differential signals can be easily adjustable with equalization, output swing and gain adjustment by either pin or I2C control settings. It can optimize the DP/USB 10Gbps signal performance over a variety of physical mediums by reducing Inter-symbol interference jitters.

Non-blocking linear Redriver can provides 2x better additive jitter performance than the conventional CMOS-based Redriver. Since Linear Redriver does not block the Receiver DFE's adaptive channel controls, it can natively support DisplayPort Transparent LT(Link Training) without any dependency of the DP-Aux channels listener.

Named as "Trace Loss Canceling" technology, and supports the cascading high speed link connections between Host and Device. It means multiple linear Redriver can be placed in the link to work seamlessly to compensate high insertion loss.

The Cascading, Low Jitter and Simplicity of Gain adjustment capabilities to extend signal transmission features are ideal choice for the 8-10Gbps high speed DP Alt signal integrity solutions.

Applications

- Notebook, Desktop and AIO Personal Computers
- DP-Alt Monitors and Displays
- Active DP-Alt Cables/Adapters

Ordering Information

Part Number	Package	Description
PI3DPX1207B1ZHEX	ZH	42-Pin, Very Thin Quad Flat No-Lead (TQFN)
PI3DPX1207B1ZHIEX	ZH	42-Pin, Very Thin Quad Flat No-Lead (TQFN)

Notes:

1. No purposely added lead. Fully EU Directive 2002/95/EC (RoHS), 2011/65/EU (RoHS 2) & 2015/863/EU (RoHS 3) compliant.
2. See <https://www.diodes.com/quality/lead-free/> for more information about Diodes Incorporated's definitions of Halogen- and Antimony-free, "Green" and Lead-free.
3. Halogen- and Antimony-free "Green" products are defined as those which contain <900ppm bromine, <900ppm chlorine (<1500ppm total Br + Cl) and <1000ppm antimony compounds.
4. E = Pb-free and Green
5. X suffix = Tape/Reel
6. I = Industrial Temperature