



New Product Announcement

AL17051

Ultra-Low Standby Power 700V Buck Converter for Smart Connected/IoT Applications

The AL17051 is a universal AC, high-voltage input, step-down converter that provides accurate 3.3V or 5V output, with dynamic performance and load regulation without requiring an optocoupler.

Typical applications include supplying power for offline low-power IoT (internet of things) devices that support WPAN (wireless personal area network) connectivity.

To support always-on requirements of IoT connectivity, the AL17051 features an ultra-low standby operation power of 10mW. It achieves a high 60% conversion efficiency at 50mA output current, and 50% at 10mA light loading during idle and sleep modes for IoT systems.

With a high-degree of integration, including a 700V high-voltage MOS switch, the device is designed to reduce external components and minimize e-BOM (bill of materials) with a small form-factor package and PCB space.

The part has rich protection features to enhance system safety and reliability. It has overtemperature protection, VCC undervoltage lock-out function, overcurrent protection, and overload protection.

The AL17051 comes in two variants, a 3.3V output and a 5V output version. Both are available in the SOT25 package.

The Diodes logo is a registered trademark of Diodes Incorporated in the United States and other countries.

All other trademarks are the property of their respective owners.

© 2022 Copyright Diodes Incorporated. All Rights Reserved.



The DIODES Advantage

The AL17051 is a low-standby power, non-isolated, high-voltage buck switcher for smart connected/IoT devices.

- **Integrated 700V MOSFET Supports Universal Mains Input Voltages**

Minimal external components required to provide a constant voltage power supply for MCU or other IoT devices

- **Two Fixed-Output Variants of 3.3V and 5V Output Voltages**

Requires no external resistor divider, minimizing BOM component count

- **High Efficiency at Both Full Load and Light Load (50% at Light Load 10mA)**

Enables systems to meet the latest energy efficiency targets

- **10mW Ultra-Low Standby Power**

Enables IoT devices to surpass latest standby power standards

- **Multiple Built-In Protections Against Anomalies**

Enhances system safety and reliability

Applications

- Power supply for Zigbee®/Bluetooth® Low Energy (BLE) in:
 - IoT connected lighting
 - Smart home appliances
- Standby and auxiliary power supplies
- Industrial controls

Typical Application

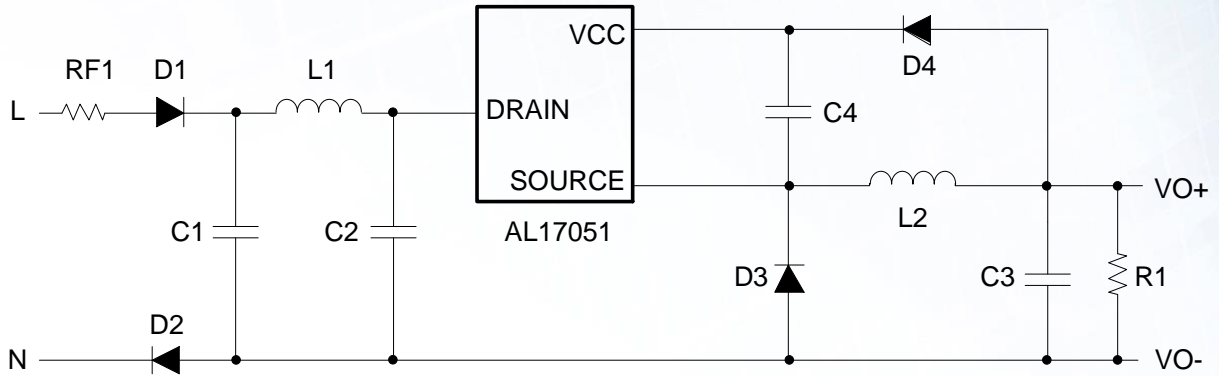

Product Portfolio

Part Number	Min. Input Voltage	Max. Input Voltage	Internal MOS BV	Output Voltage	Max. Output Current	Reference Voltage Accuracy	Max. Switching Frequency	Standby Power	Efficiency	Ambient Temp. Range	Package
	Vac	Vac	V	V	mA	±%	kHz	mW	%	°C	
AL17051V33	85	300	700	3.3	50	2.5	50	10	60	-40 to +105	SOT25
AL17051V5	85	300	700	5	50	2.5	50	10	65	-40 to +105	SOT25
AL17050	85	265	500	Set by external resistor	50	4	30	50	60	-40 to +105	SOT25
AL17150-10B	85	265	500	Set by external resistor	300	4	35	60	60	-40 to +105	SO-7

Ordering Information

Orderable Part Number	Compliance (Only Automotive Supports PPAPs)	Package	Moisture Sensitivity	Packing	
				Quantity	Carrier
AL17051V33W5-7	Standard	SOT25	MSL-1	3,000	7" Tape and Reel
AL17051V5W5-7	Standard	SOT25	MSL-1	3,000	7" Tape and Reel