

PI6CG18801 EVB Use Manual

Timing Application Engineering

1.1 Introduction

PI6CG18801 is 1.8V PCIe clock generator family product. Its low power HCSL output makes the IC has very low power consumption in high performance to comply with PCIe 1.0, 2.0, and 3.0 PCI_SIG.org reference clock waveform and jitter specifications. This doc. is to provide the EVB use guide and test example.

1.2 DUT Reference

1. Datasheet
2. EVB PCB and schematic
3. Device application circuit

1.3 EVB Photo and Test Diagram

- 1) EVB photo and connection guide

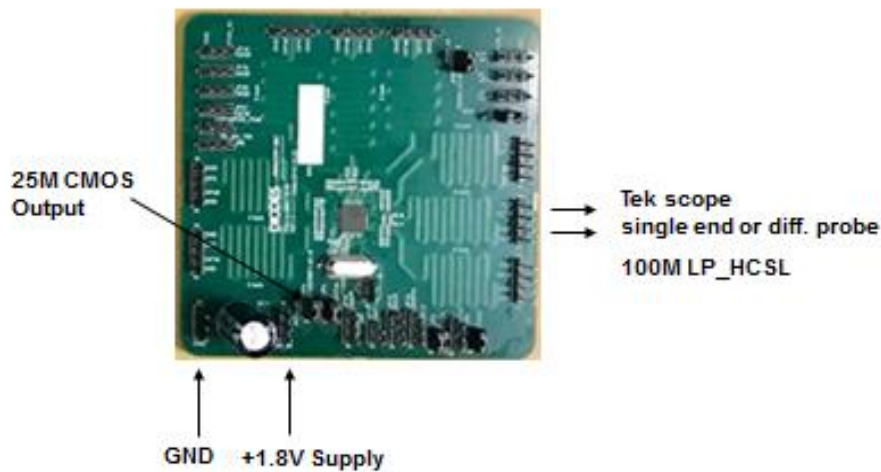

- 2) LP_HCSL test diagram

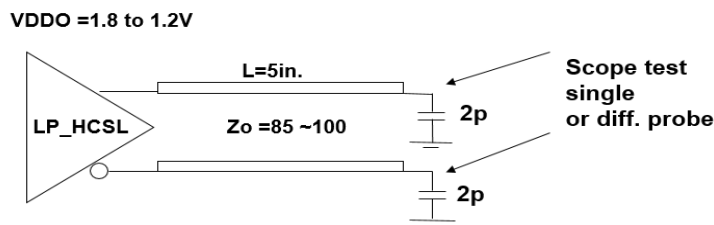

1.3 Equipment

Agilent DC supply: E3631A
Tektronix real time scope 20G/S: TDS7404

2.1 Summary

- i) The EVB has total current $I_{dd} = 17\text{mA}@1.8\text{V}$;
- ii) The single output waveform $T_r/T_f = 363/389\text{ps}$; $V_{amp} = 806\text{mV}$
- iii) differential output waveform $T_r/T_f = 406/415\text{ps}$; $V_{amp} = 1.62\text{V}$
- iv) The EVB meets design spec.

3.1 Test Reference Waveform

1) Tek scope single end probe waveform

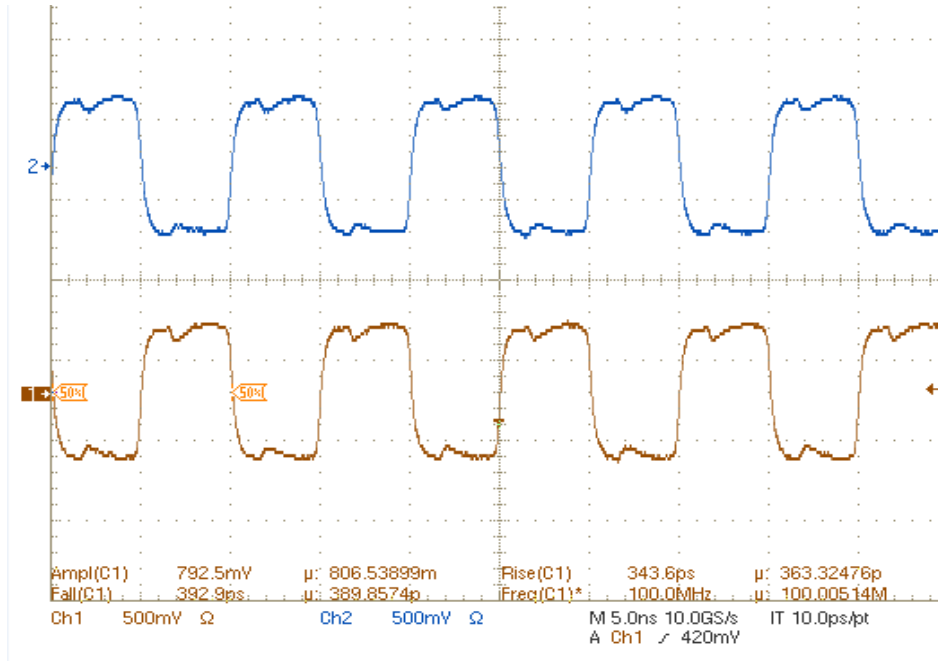

2) Tek scope differential probe waveform

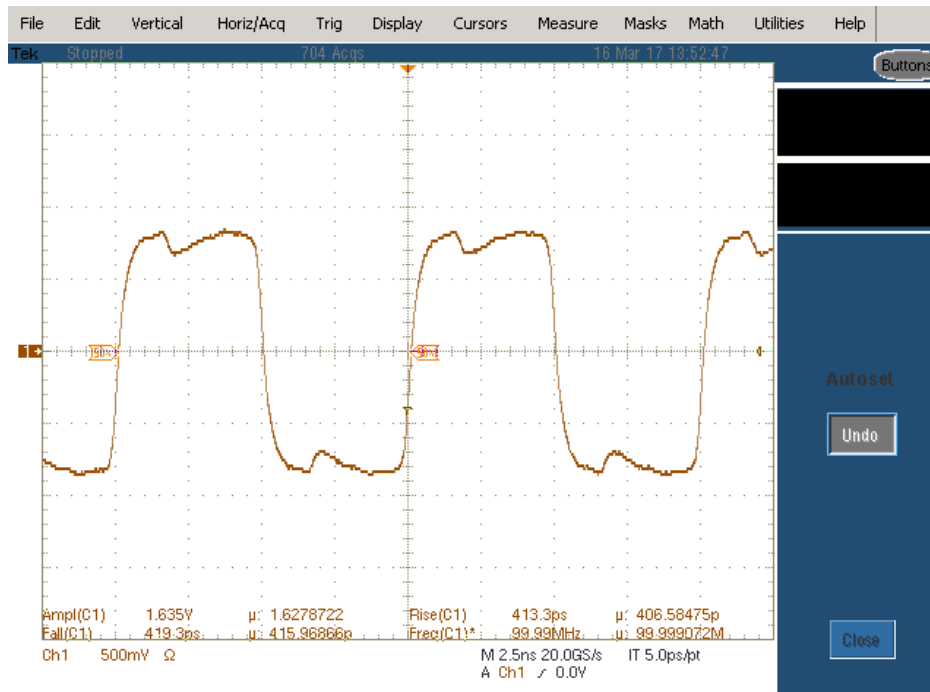

3.2 EVB PCB Layout

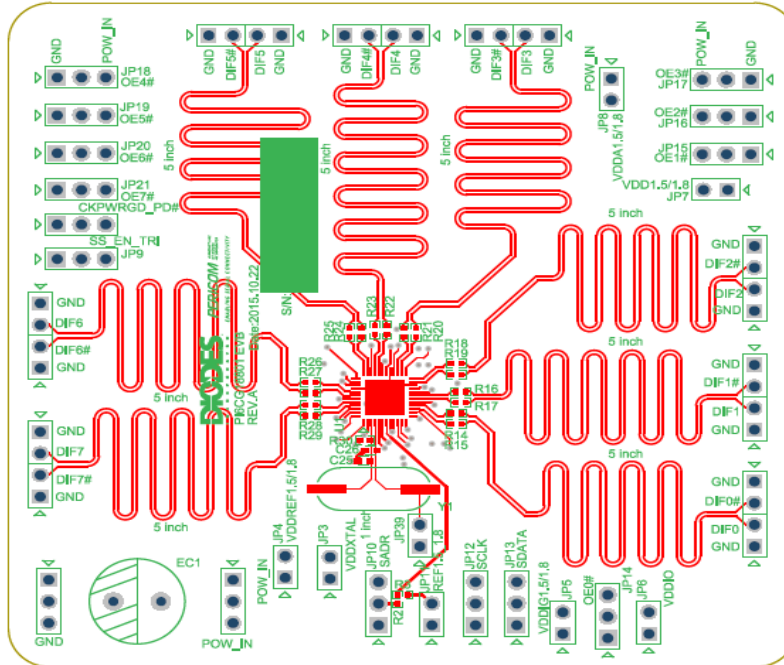

3.3 EVB Schematic

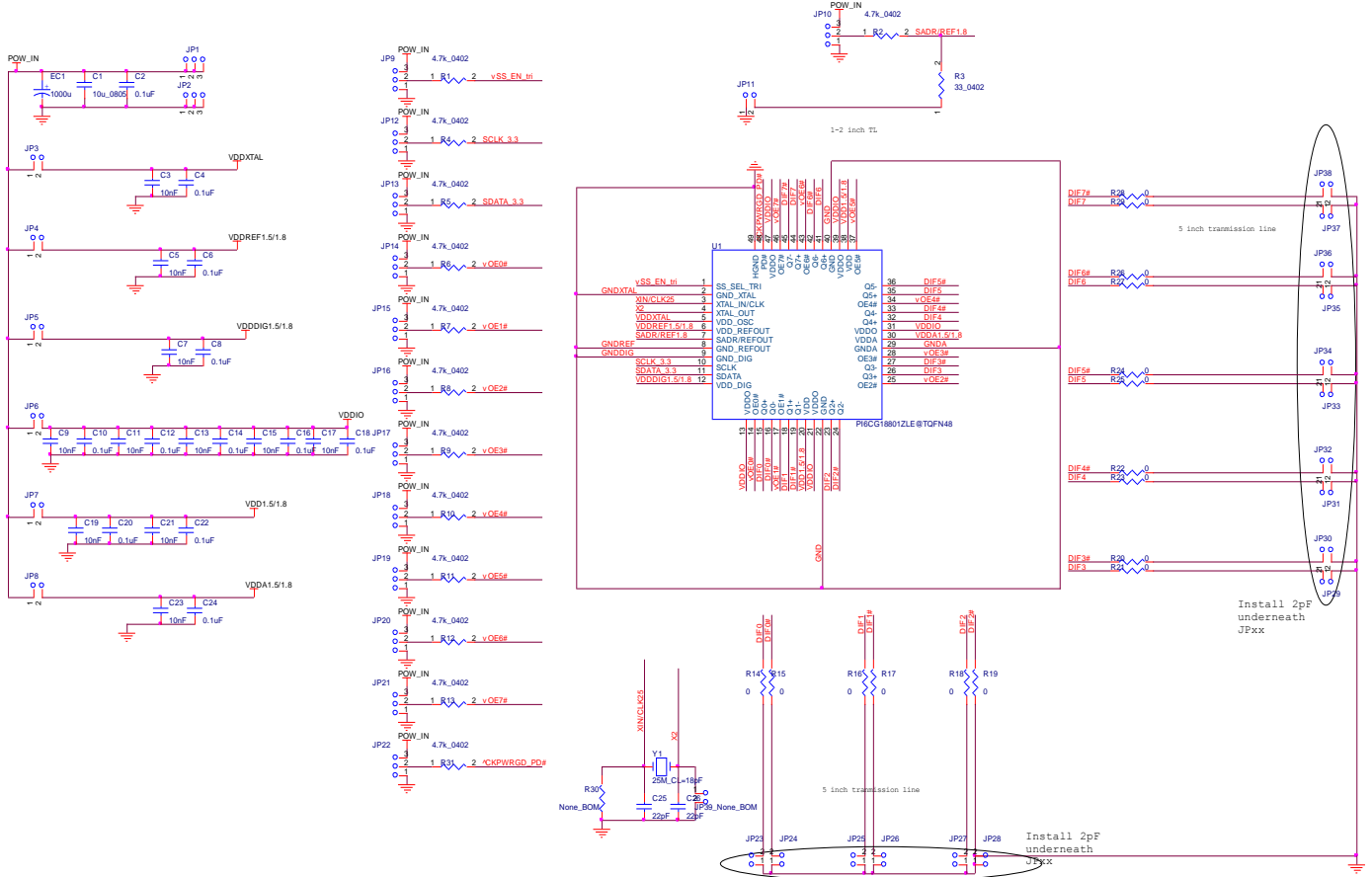

3.4 PI6CG18801 Application Circuit

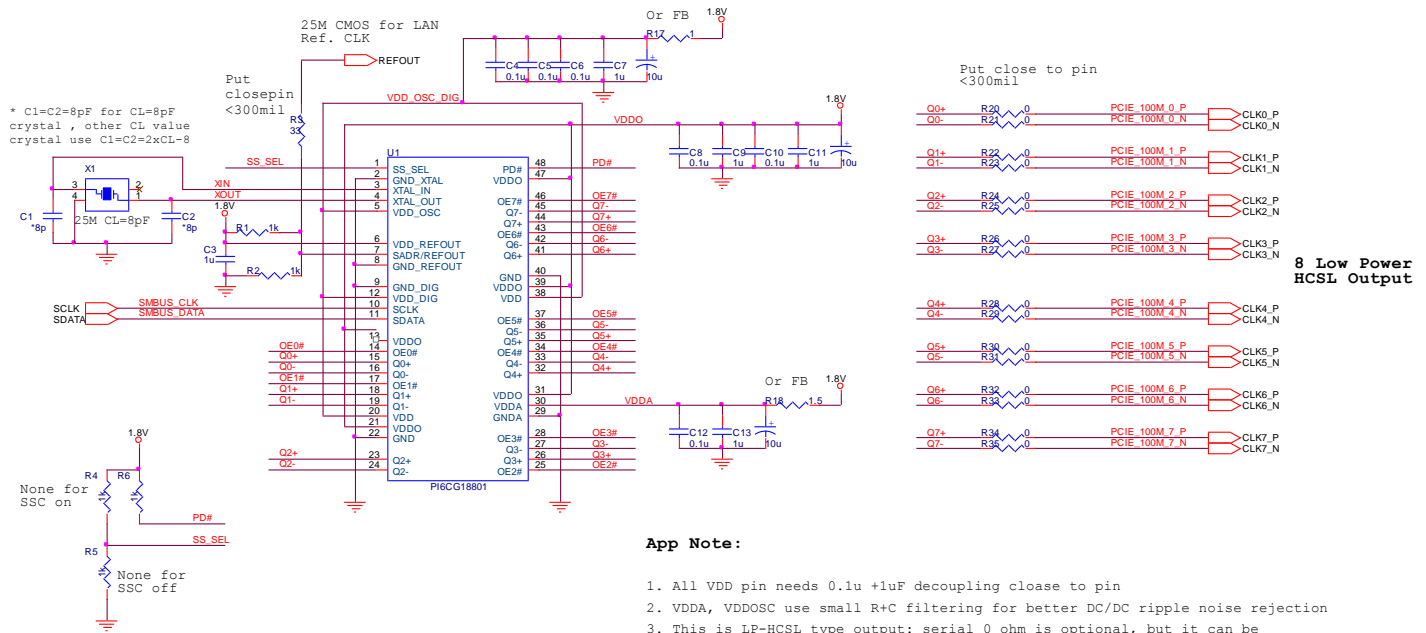

App Note:

1. All VDD pin needs 0.1u +1uF decoupling close to pin
2. VDDA, VDDOSC use small R+C filtering for better DC/DC ripple noise rejection
3. This is LP-HCSL type output: serial 0 ohm is optional, but it can be replace in 5 to 15 ohm for the optimal fine tune the board RX end waveform for different trace length if needed
4. Since OSC pin cap.=5pF so select CL=8pF crystal can C1=C2=8pF, other CL value crystal CL=C2=2xCL-5-3, 3 is C_stray pF
5. Note SSC_EN and SMBUS address pins are power on latch once set;
6. Make LVDS clock, it needs AC coupling and then RX side use pull-up/down Rs to bias LVDS level, refer to datasheet;
7. OEx# pins have internal pull-up, can be left open

Document History

Revision	Date	Description	Author
1.0	Mar, 2017	1 st rev. doc	Timing AE