

* C1=C2=27pF for CL=18pF crystal, other CL value crystal use C1=C2=2x(CL-4)

Diodes Pericom Crystal
Product: FY2500047
R7* for fine tune the drive level limit.

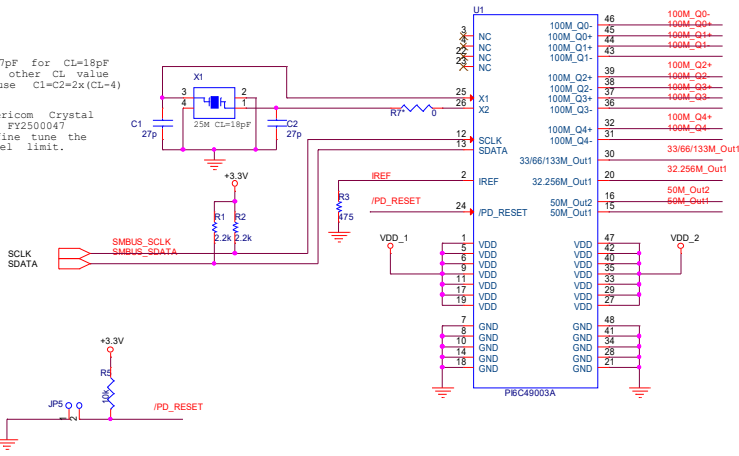

/PD_RESET:
Set /PD_RESET logic in R5/JP5 :
0: Power Down RESET
1: Enable

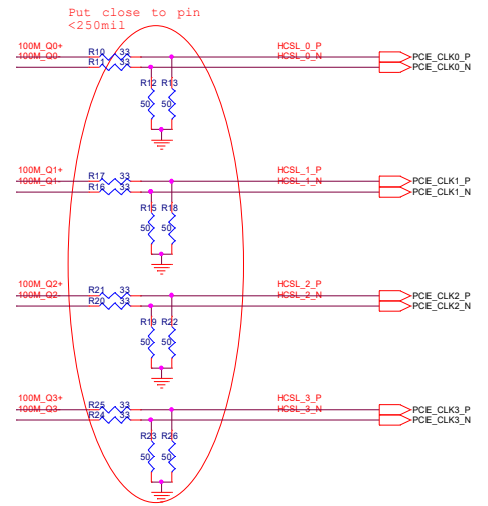

App Note:

1. Each VDD pin needs 0.1u +1uF decoupling close to pin.
2. VDD uses small R=1-2 ohm or FB(ferrite bead)+C=10uF filtering for better DC/AC ripple noise rejection
3. This is HCSL type output: Place 33ohm serial and 50 ohm pull down <250mil close to IO output pins on comp. side.
4. Leave unused 100M_Qx+ and 100M_Qx- open
5. IREF pin: A 475 ohm resistor to GND.

Title			
PIC49003A Application Schematic			
Size	Document	Number	Rev
B	Diodes Inc.	Clock IC application engineering	1.0
Date:	Friday, March 29, 2024	Sheet	1 of 1