

**Package Outline Dimensions**

U-WLB2626-36

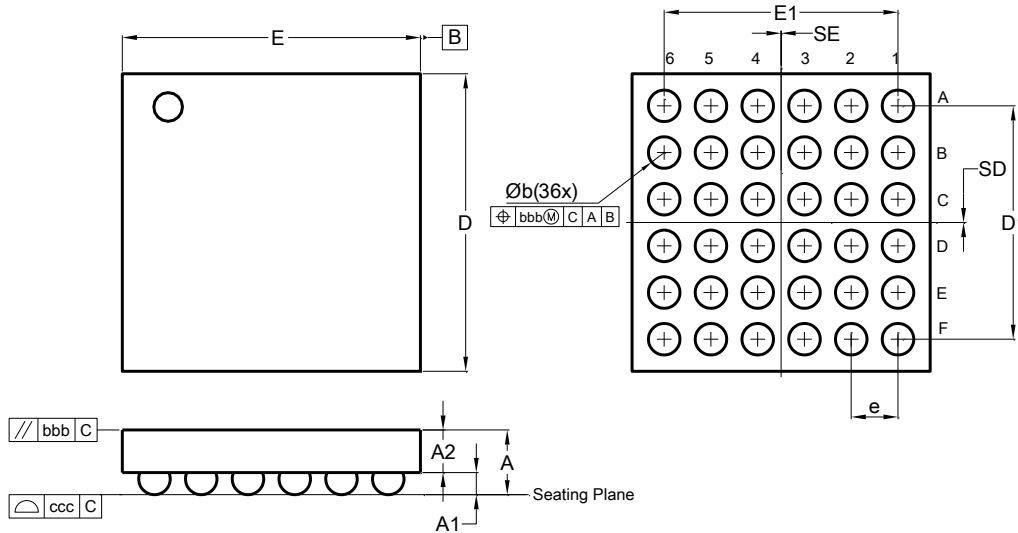

U-WLB2626-36			
Dim	Min	Max	Typ
A	0.520	0.590	0.555
A1	0.170	2.10	0.190
A2	0.350	0.380	0.365
b	0.240	0.300	0.270
D	2.500	2.600	2.550
D1	1.950	2.050	2.000
E	2.500	2.600	2.550
E1	1.950	2.050	2.000
e	0.400 BSC		
SD	0.000 BSC		
SE	0.000 BSC		
aaa	0.10		
bbb	0.10		
ccc	0.05		
All Dimensions in mm			

**Suggested Pad Layout**

U-WLB2626-36

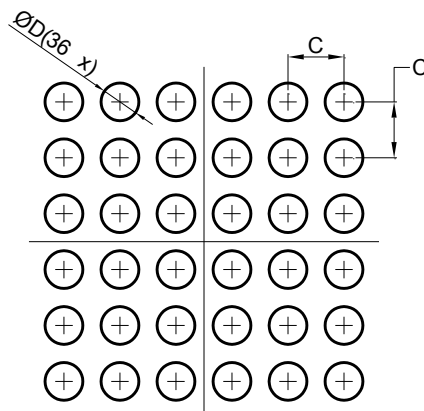

Dimensions	Value (in mm)
C	0.400
D	0.270

**ALL DIMENSIONS ARE NOMINAL VALUES SHOWN IN MILLIMETERS**

Note: The suggested land pattern dimensions have been provided for reference only, as actual pad layouts may vary depending on application. These numbers may be modified based on user equipment capability or fabrication criteria. A more robust pattern may be desired for wave soldering and is calculated by adding 0.2 mm to the 'Z' dimension. For further information, please reference document IPC-7351A, Naming Convention for Standard SMT Land Patterns, and for International grid details, please see document IEC, Publication 97.