

SYMBOL	DIMENSION IN MM		
	MIN.	NOM	MAX.
A	--	--	2.00
A1	0.05	--	0.25
A2	1.45	1.60	1.75
c	0.09	--	0.20
c1	0.09	0.13	0.16
E	5.80	6.00	6.20
E1	3.80	3.90	4.00
L	0.50	0.60	0.75
L1	0.25 BASIC		
θ	0	--	8
R1	0.09	--	--
b	0.17	--	0.27
b1	0.17	0.20	0.23
D	20.40	20.50	20.60
e	0.50 BASIC		

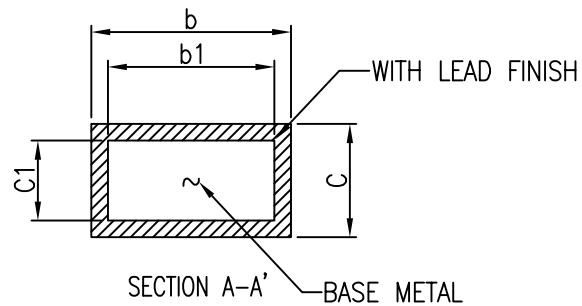
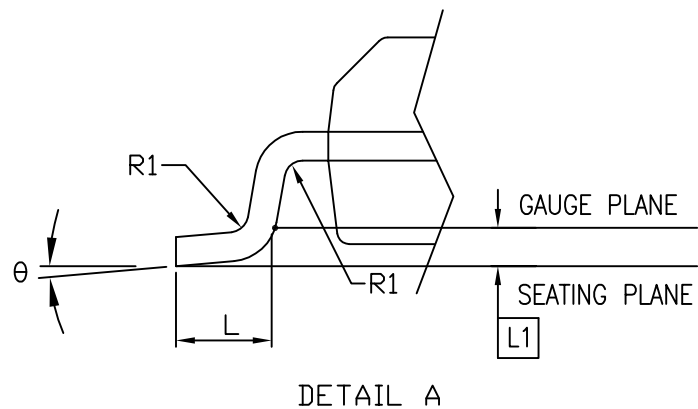

- Notes:
1. Controlling Dimension in Millimeters. Angle in Degrees.
 2. Refer JEDEC MO-154/BC
 3. Package Outline Exclusive of Mold Flash and Metal Burr

<small>A PRODUCT LINE OF DIODES INCORPORATED</small> <small>ENABLING SERIAL CONNECTIVITY</small>	DATE: 09/05/16
	DESCRIPTION: 80-Pin, 150mil Wide BQSOP
PACKAGE CODE: B (B80)	
DOCUMENT CONTROL #: PD-1211	REVISION: E