

Customer Notification of Product/Process Changes

*PCN No.: PCN-0084

*Issued Date: May/22/2018

*Subject: Change TVS Die size from 56mil to 60mil

*Effective date: Aug/22/2018

*Affected category: SMD

*Affected Family: DO-219(F1A)

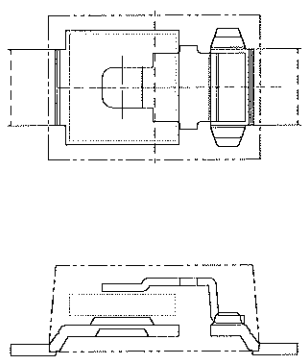
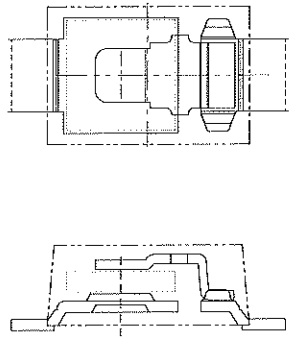
Change Item	<input checked="" type="checkbox"/> Material <input checked="" type="checkbox"/> Design <input type="checkbox"/> Process <input type="checkbox"/> Others	
Impact Item	1. Product P/N : <input type="checkbox"/> Yes <input checked="" type="checkbox"/> No 2. Marking : <input type="checkbox"/> Yes <input checked="" type="checkbox"/> No	3. Label : <input type="checkbox"/> Yes <input checked="" type="checkbox"/> No 4. Other items : <input type="checkbox"/> Yes <input checked="" type="checkbox"/> No
Other Related Item	1. BOM changing 2. Inner structure changing	
Change Purpose	1. Quality improvement --- IPP From 100%IPP capability to 120% lpp capability	
Description of Change	Before Change	After Change
	<p>Die size: 56mil & Inner structure</p> 	<p>Die size:60mil & Inner structure</p> 

Customer Approve Form For Engineering Change

Description of Change	Before Change	After Change
	1. Die size: 56mil	1. Die size: 60mil
Related Report	<input checked="" type="checkbox"/> Electrical Test Report (as the attachment) <input type="checkbox"/> SGS / MCD_MDS Report <input type="checkbox"/> ESD Report (as the attachment) <input type="checkbox"/> Mechanical Test Report <input checked="" type="checkbox"/> Others (ex. Impacted part list) (as the attachment)	
Sample availability	<input checked="" type="checkbox"/> Yes <input type="checkbox"/> No	
Customer Approval	<input type="checkbox"/> Approve <input type="checkbox"/> Disapprove	
Customer Requirement (ex. Last Buy requirement)		

(Note):

- 1.If you need sample(s) or any question, please contact with our Salesperson within 30day
- 2.LSC will follow WW industry standard spec (JESD46D) criteria define as below.
- A. Customers should acknowledge receipt of the PCN within 30 day period constitutes
- B. Lack of acknowledgement of the PCN within 30 days constitutes acceptance of the change.
- C. After acknowledgement, lack of additional response within the 90 day period constitutes acceptance of the change.
- D. If customer requires additional time to perform samples testing, beyond the 90 day review period an extension must be negotiate

Quality Assurance

