

ZXTR20XXEV1 USER GUIDE

Description

The board is intended for the evaluation of ZXTR20XX series high voltage 100V linear regulators with fixed 5V, 8V and 12V output voltages in SOT89, POWERDI5 and TO252. Refer to Table 1 for a detailed description.

The evaluation board is ideal for generating 5V, 8V and 12V from a nominal 24V or 48V rails connected to the common input on the board. It can supply well-regulated voltage rails, as well as, withstand and maintain regulation during very high and fast voltage transients.

The board can provide regulated 5V output from an input voltage within the range of 8V to 100V. Regulated 8V and 12V outputs can be provided from input voltage ranges of 12V to 100V and 15V to 100V, respectively. All the outputs can provide up to 50mA output current.

Load can be applied to all the 9 outputs either individually or simultaneously as long as the maximum temperature rating is not exceeded. Refer to the datasheets for further details on max operating conditions and regulation tolerances.

	5V Output	8V Output	12V Output
SOT89	ZXTR2005Z	ZXTR2008Z	ZXTR2012Z
POWERDI5	ZXTR2005P5	ZXTR2008P5	ZXTR2012P5
TO252 (DPAK)	ZXTR2005K	ZXTR2008K	ZXTR2012K

Table 1

Ordering Information

ORDER NUMBER
ZXTR20XXEV1

Please note evaluation boards are subject to availability and qualified leads

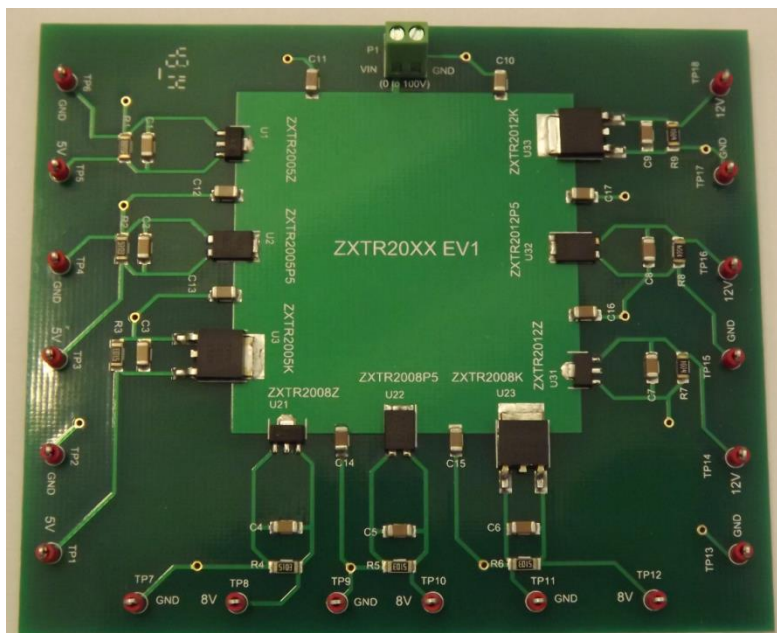

Figure 1 ZXTR20XXEV1 evaluation board

Quick Start Guide

Connect a DC supply voltage to the terminal block P1 and once this voltage is set to the right range (recommended min voltage for 5V, 8V and 12V regulation is 10V, 12V and 15V respectively) test points will start to regulated the voltage at rated value. Required loads can be connected to the test points. Typical performance details are provided in the sections below.

ZXTR20XXEV1 Schematic

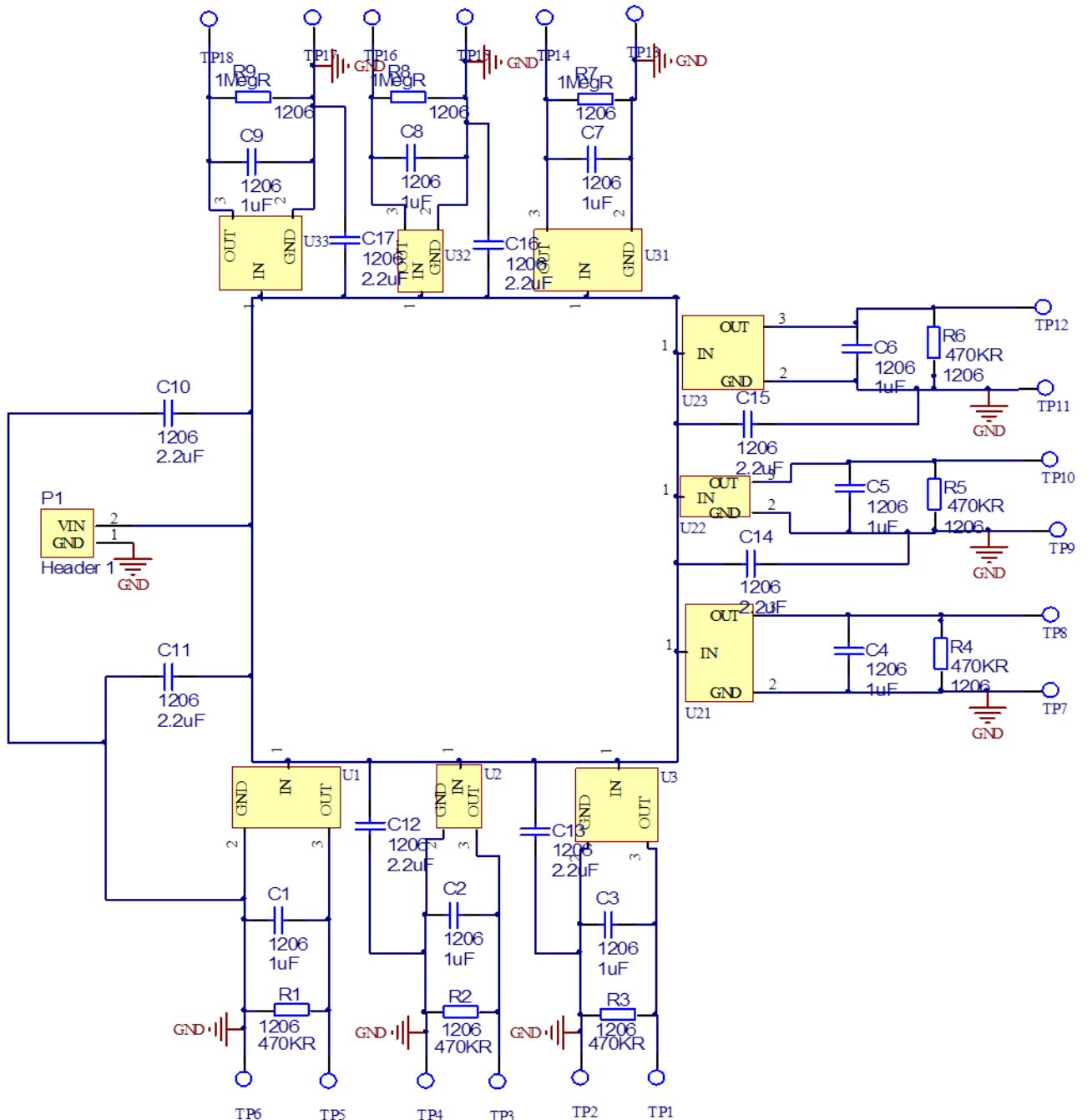

Figure 2 Evaluation board schematic diagram.

Parts List

Designator	Description	Package	Part Number	Manufacturer
C1, C2, C3, C4, C5, C6, C7, C8, C9	Capacitor, 1uF 50V X7R C1206X105K5RACTU	1206	C1206X105K5RACTU	Farnell
C10, C11, C12, C13, C14, C15, C16, C17	Capacitor, 2.2uH 100V X7R 12061C225KAT2A	1206	12061C225KAT2A	Farnell
P1	Phoenix Terminal Block, 2 way, 1725656	1206	1725656	Farnell
R1, R2, R3, R4, R5, R6	RESISTOR, THICK FILM, 510KOHM, 250mW, 1%	1206	CRCW1206510KFKE A	Farnell
R7, R8, R9	RESISTOR THICK FILM, 1MOHM, 1%, 1206	0805	CR1206-FX-1004ELF	Farnell
TP1, TP2, TP3, TP4, TP5, TP6, TP7, TP8, TP9, TP10, TP11, TP12, TP13, TP14, TP15, TP16, TP17, TP18	Vero loop terminal test point 20-313137	test point 20-313137	20-313137	Farnell
U1, U21, U31	5V voltage regulators	SOT89 PowerDI5 TO252 (DPAK)	ZXTR2005Z ZXTR2005P5 ZXTR2005K	Diodes Inc
U2, U22, U32	8V voltage regulators	SOT89 PowerDI5 TO252 (DPAK)	ZXTR2008Z ZXTR2008P5 ZXTR2008K	Diodes Inc
U3, U23, U33	12V voltage regulators	SOT89 PowerDI5 TO252 (DPAK)	ZXTR2012Z ZXTR2012P5 ZXTR2012K	Diodes Inc

Table 1 Parts list

Performance

Figure 3 to 8 show the performance of the ZXTR20XXEV1. Figure 3 shows the quiescent current of the ZXTR20XX is less than 2.5mA at VIN=48V when the VOUT terminals are left floating.

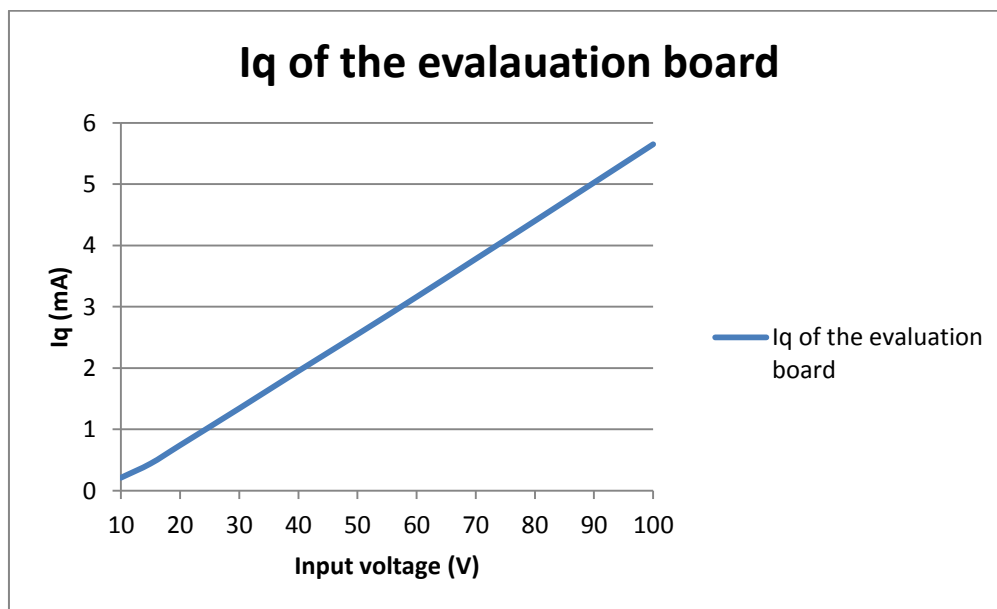

Figure 3 Quiescent supply current vs. supply voltage V_{CC}

For a fixed load of 15mA, figure 4 shows the regulation of three output voltages as the input voltage is swept from their respective minimum voltages to 100V. Load is applied to one output at a time.

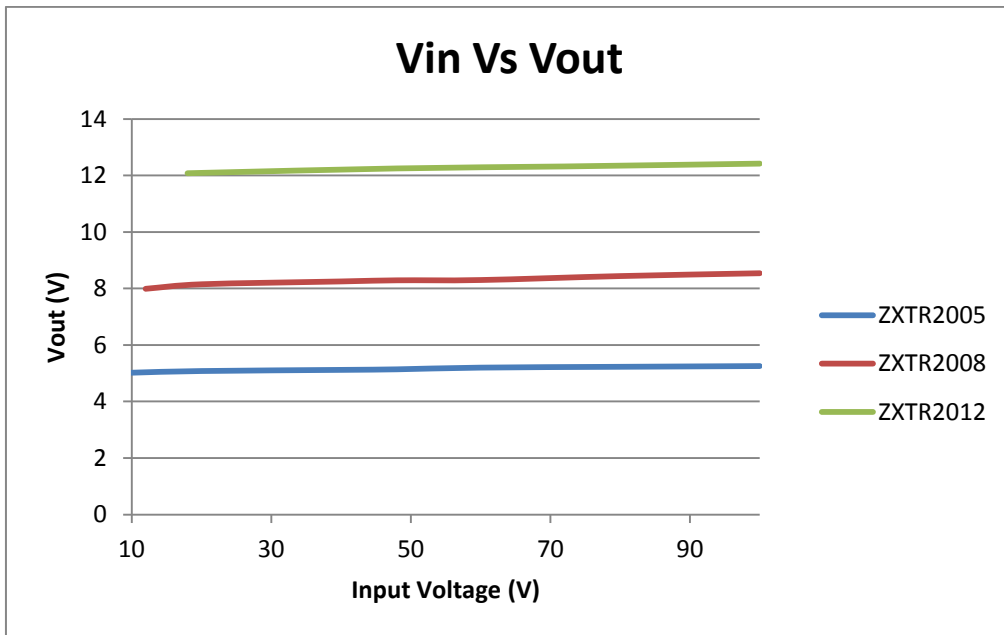

Figure 4 Input voltage VIN regulation

For a fixed input voltage of 48V, figure 5 shows the regulation of three output voltages as the load current is swept. Load is applied to one output at a time.

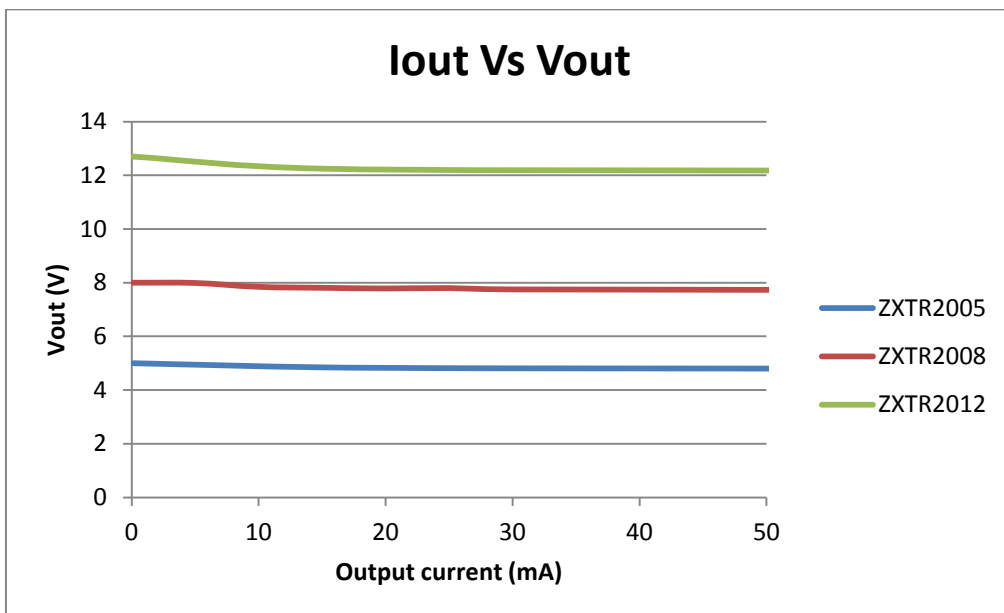
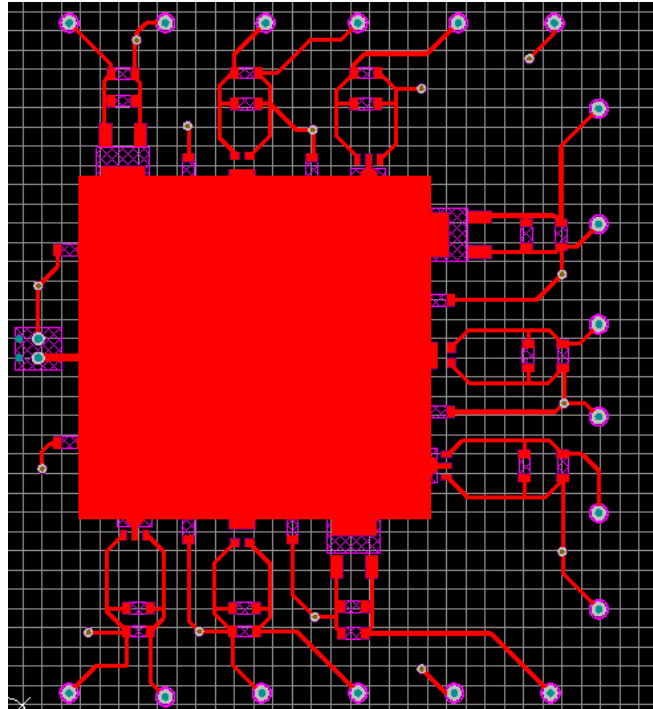
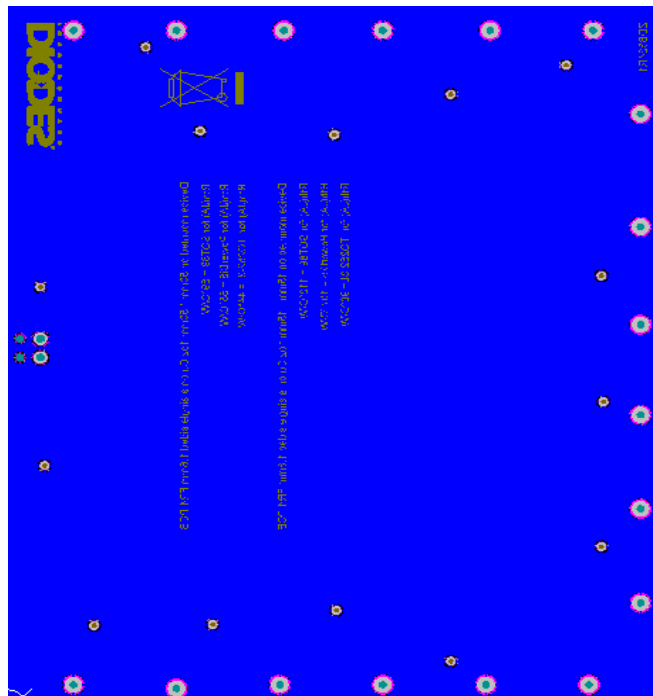

Figure 5 Output load regulation

PCB Layout



Top side



Bottom side

IMPORTANT NOTICE

DIODES INCORPORATED MAKES NO WARRANTY OF ANY KIND, EXPRESS OR IMPLIED, WITH REGARD TO THIS DOCUMENT, INCLUDING, BUT NOT LIMITED TO, THE IMPLIED WARRANTIES OF MERCHANTABILITY AND FITNESS FOR A PARTICULAR PURPOSE (AND THEIR EQUIVALENTS UNDER THE LAWS OF ANY JURISDICTION).

Diodes Incorporated and its subsidiaries reserve the right to make modifications, enhancements, improvements, corrections or other changes without further notice to this document and any product described herein. Diodes Incorporated does not assume any liability arising out of the application or use of this document or any product described herein; neither does Diodes Incorporated convey any license under its patent or trademark rights, nor the rights of others. Any Customer or user of this document or products described herein in such applications shall assume all risks of such use and will agree to hold Diodes Incorporated and all the companies whose products are represented on Diodes Incorporated website, harmless against all damages.

Diodes Incorporated does not warrant or accept any liability whatsoever in respect of any products purchased through unauthorized sales channels. Should Customers purchase or use Diodes Incorporated products for any unintended or unauthorized application, Customers shall indemnify and hold Diodes Incorporated and its representatives harmless against all claims, damages, expenses, and attorney fees arising out of, directly or indirectly, any claim of personal injury or death associated with such unintended or unauthorized application.

Products described herein may be covered by one or more United States, international or foreign patents pending. Product names and markings noted herein may also be covered by one or more United States, international or foreign trademarks.

LIFE SUPPORT

Diodes Incorporated products are specifically not authorized for use as critical components in life support devices or systems without the express written approval of the Chief Executive Officer of Diodes Incorporated. As used herein:

- A. Life support devices or systems are devices or systems which:
1. are intended to implant into the body, or
 2. support or sustain life and whose failure to perform when properly used in accordance with instructions for use provided in the labeling can be reasonably expected to result in significant injury to the user.
- B. A critical component is any component in a life support device or system whose failure to perform can be reasonably be expected to cause the failure of the life support device or to affect its safety or effectiveness.

Customers represent that they have all necessary expertise in the safety and regulatory ramifications of their life support devices or systems, and acknowledge and agree that they are solely responsible for all legal, regulatory and safety-related requirements concerning their products and any use of Diodes Incorporated products in such safety-critical, life support devices or systems, notwithstanding any devices- or systems-related information or support that may be provided by Diodes Incorporated. Further, Customers must fully indemnify Diodes Incorporated and its representatives against any damages arising out of the use of Diodes Incorporated products in such safety-critical, life support devices or systems.

Copyright © 2015, Diodes Incorporated

www.diodes.com