

## ZXSC400EV4 USER GUIDE

### DESCRIPTION

The ZXSC400 is voltage mode boost converter in SOT23-6 package. Its low feedback voltage allows the current in a chain of LEDs to be set and accurately monitored with a single resistor with minimal losses.

### FEATURES

- Drives a 1W white LED at 350mA
- Typical efficiency of 80%

The ZXSC400EV4 is configured as a boost converter to drive a 1W LED from two NiCd/NiMH batteries.

### APPLICATIONS

- LED torches
- High Power LED driving

### ORDERING INFORMATION

<b>ORDER NUMBER</b>
ZXSC400EV4

Please note evaluation boards are subject to availability and qualified leads.

### TYPICAL APPLICATION CIRCUIT

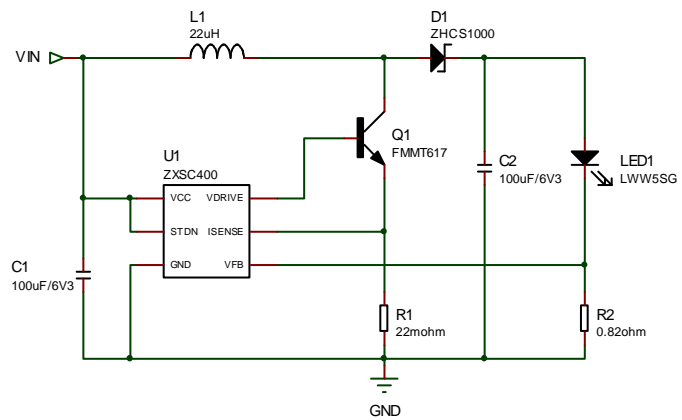

## REFERENCE DESIGN

ZXSC400EV4 is configured to the reference design below. The target application is a 1W white LED Driving from two NiCd/NiMH battery input for torches and high powered LED driving.

The supply voltage for ZXSC400EV4 is:  $V_{IN}=3V \sim 1.8V$ .

For other reference designs or further applications information please refer to the ZXSC400 datasheet.

## Schematic Diagram

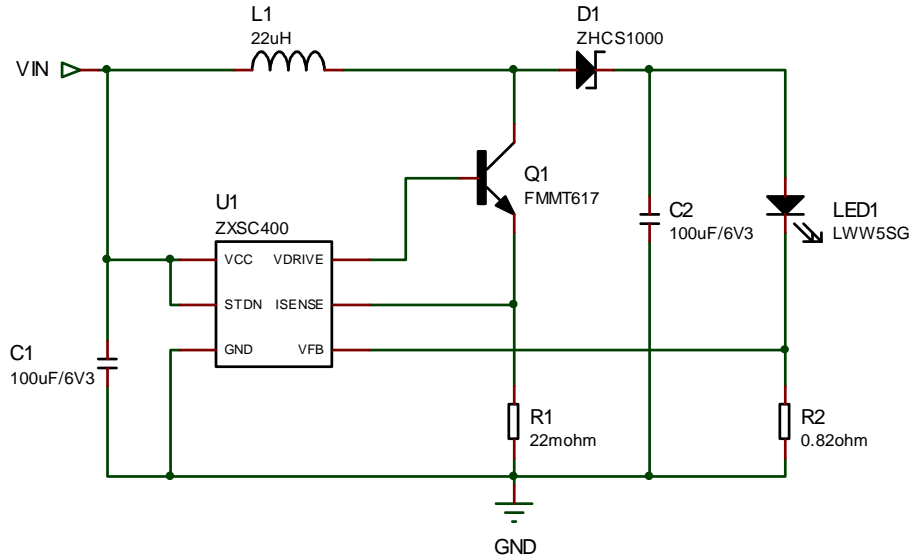

## Materials List

Ref	Value	Package	Part Number	Manufacturer	Notes
U1	N/A	SOT23-6	UZXS400E6	Zetex	Boost converter
Q1	N/A	SOT23	UFMMT617	Zetex	Low sat NPN transistor
D1	40V/1A	SOT23	UZHCS1000	Zetex	40V/1A Schottky diode
L1	22uH/2.5A	N/A	DO3316P-223	Coilcraft	22uH/2.5A SMT Inductor
R1	22mΩ	0805		Generic	0805 5% tolerance
R2	0.82Ω	0805		Generic	0805 5% tolerance
C1	100μF/6V3	1812	GRM43SR60J107ME20L	Murata	100uF/6V3/X5R/1812
C2	100μF/6V3	1812	GRM43SR60J107ME20L	Murata	100uF/6V3/X5R/1812
LED1	1W	N/A	LW W55G-GYHY-5K8L	Osram Opto Semiconductors	1W Golden Dragon™ WLED

**PERFORMANCE**

**Increasing efficiency**

On ZXSC400EV3, R1 is set to 22mΩ to ensure that the LED current is regulated over the full input voltage range of 3V ~ 1.8V. For improved efficiency R1 can be changed to a 33mΩ resistor but LED current will not be regulated below 2V. See performance graphs.

**Graphs**

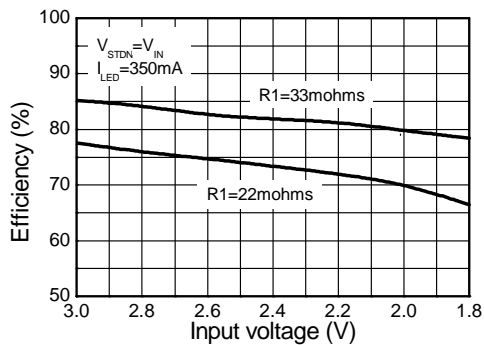

**Efficiency vs Input Voltage**

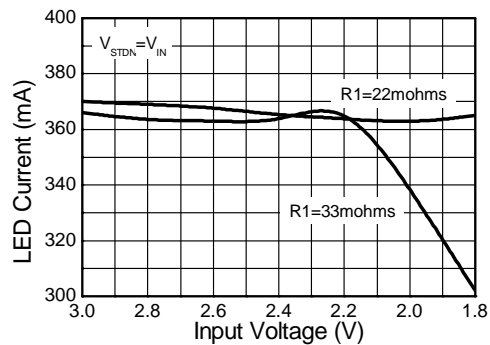

**LED Current vs Input Voltage**

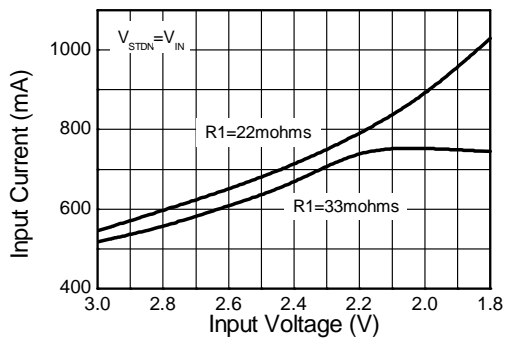

**Input Current vs Input Voltage**

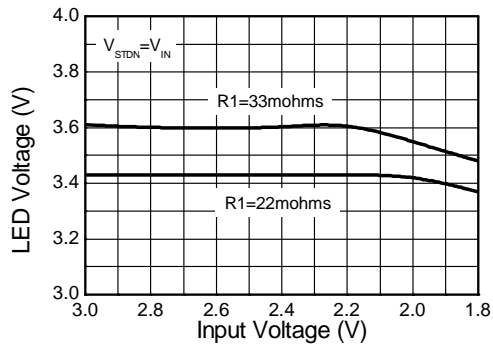

**LED Voltage vs Input Voltage**

## ZXSC400EV3 OPERATION

### Connection diagram

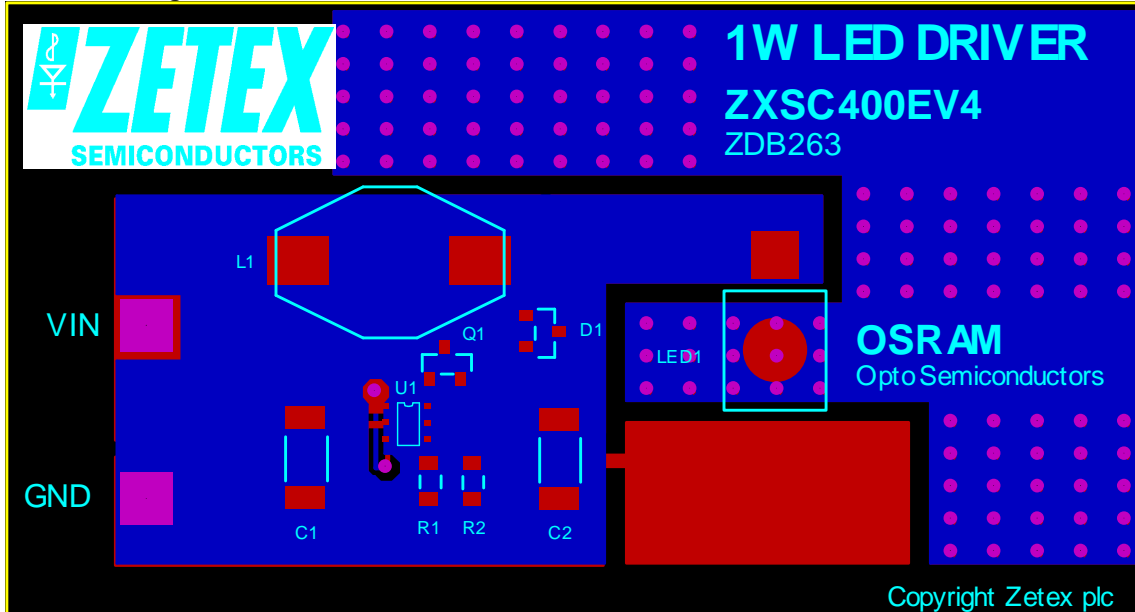

### ZXSC400EV4 Set-up and Test

1. Connect  $V_{IN}$  and GND to positive and zero volts of PSU supply respectively.
2. Set the PSU to 3V.
3. Turn on PSU.
4. The LED should illuminate and be regulated at 350mA.
5. Input current should measure between 0.5A ~ 0.6A - **THIS IS A FUNCTIONAL EVAL BOARD.**

## Layout considerations

PCB tracks should be kept as short as possible to minimise ground bounce, and the ground pin of the device should be soldered directly to the ground plane. It is particularly important to mount the coil and the input/output capacitors close to the device to minimise parasitic resistance and inductance, which will degrade efficiency. The FB pin is a high impedance input, so PCB track lengths to this should also be kept as short as possible to reduce noise pickup. Excess capacitance from the FB pin to ground should be avoided.

Below is the recommended layout of the ZXSC400EV4.

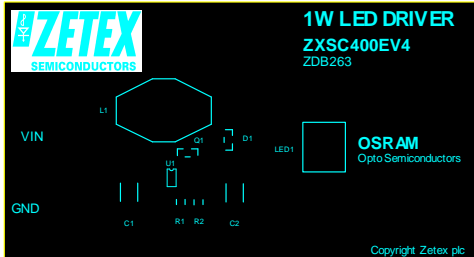

Top Silk

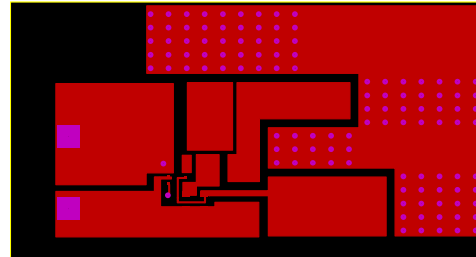

Top Copper

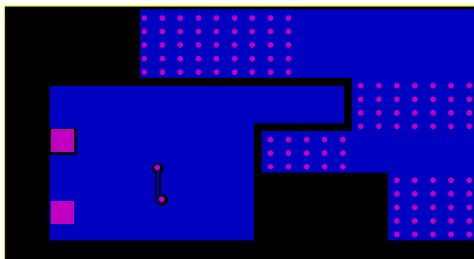

Bottom Copper

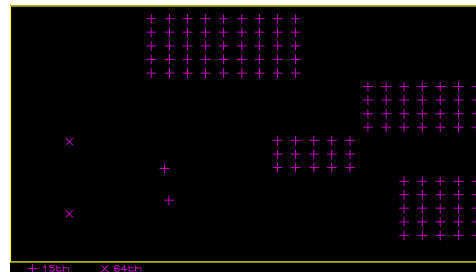

Drill File



© Zetex Semiconductors plc 2005

---

<b>Europe</b>	<b>The Americas</b>	<b>Asia</b>	<b>Corporate Headquarters</b>
Zetex GmbH Streitfeldstraße 19 D-81673 München Germany Telefon: (49) 89 45 49 49 0 Fax: (49) 89 45 49 49 49 email: <a href="mailto:europa.sales@zetex.com">europa.sales@zetex.com</a>	Zetex Inc 700 Veterans Memorial Hwy Hauppauge, NY 11788 USA Telephone: (1) 631 360 2222 Fax: (1) 631 360 8222 email: <a href="mailto:usa.sales@zetex.com">usa.sales@zetex.com</a>	Zetex (Asia) Ltd 3701-04 Metroplaza Tower 1 Hing Fong Road, Kwai Fong Hong Kong Telephone: (852) 26100 611 Fax: (852) 24250 494 email: <a href="mailto:asia.sales@zetex.com">asia.sales@zetex.com</a>	Zetex Semiconductors plc Zetex Technology Park, Chadderton, OL9 9LL United Kingdom Telephone (44) 161 622 4444 Fax: (44) 161 622 4446 email: <a href="mailto:hq@zetex.com">hq@zetex.com</a>

---

These offices are supported by agents and distributors in major countries world-wide.

This publication is issued to provide outline information only which (unless agreed by the Company in writing) may not be used, applied or reproduced for any purpose or form part of any order or contract or be regarded as a representation relating to the products or services concerned. The Company reserves the right to alter without notice the specification, design, price or conditions of supply of any product or service.

For the latest product information, log on to [www.zetex.com](http://www.zetex.com)