

ZXLD1352EV1 USER GUIDE

DESCRIPTION

The ZXLD1352EV1, Figure 1, is an evaluation board for evaluating the ZXLD1352 350mA LED driver with internal switch. The evaluation board can be used to drive an external choice of LEDs, and the number of external connected LEDs depends on the forward voltage of the LEDs connected.

The operating voltage is nominally 24V. For three 1W series-connected LEDs, the voltage can be from 12V minimum to 30V maximum. The 100uH inductor used in the circuit is based on a nominal 24V supply, which should be connected across +VCC and GND pads. Note: The evaluation board does not have reverse battery protection. The nominal current for the evaluation board is set at 300mA with a 0.33R sense resistor, R_s .

Test point ADJ provides a connection point for DC or PWM dimming and shutdown.

Warning: At 24V nominal operation with 300mA output, the LEDs and the PCB may be hot and the LEDs will be very bright.

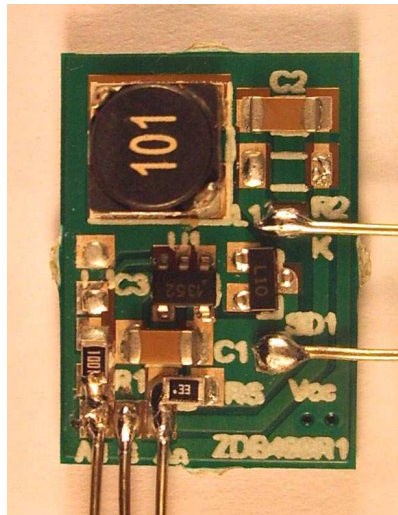

Figure 1: ZXLD1352EV1 evaluation board

ZXLD1352 DEVICE DESCRIPTION

The ZXLD1352 is a continuous mode inductive driver in a TSOT23-5 package, for driving one or more series connected LEDs efficiently from a voltage source higher than the LED voltage. The device includes the output switch and a current sense circuit, which requires an external sense resistor to set the nominal current up to 350mA. The device is particularly suitable for high resolution PWM dimming.

ZXLD1352 DEVICE FEATURES

- Drives one or more series-connected 1W white LEDs up to 350mA.
- Internal 30V switch.
- Wide input voltage: 7V to 30V.
- Inherent open circuit LED protection.
- Brightness control using DC or PWM.
- PWM dimming resolution up to 10bit.

DEVICE APPLICATIONS

- LED flashlights.
- High Power LED driving.
- Low-voltage halogen replacement LEDs.
- Automotive lighting.
- Illuminated signs.

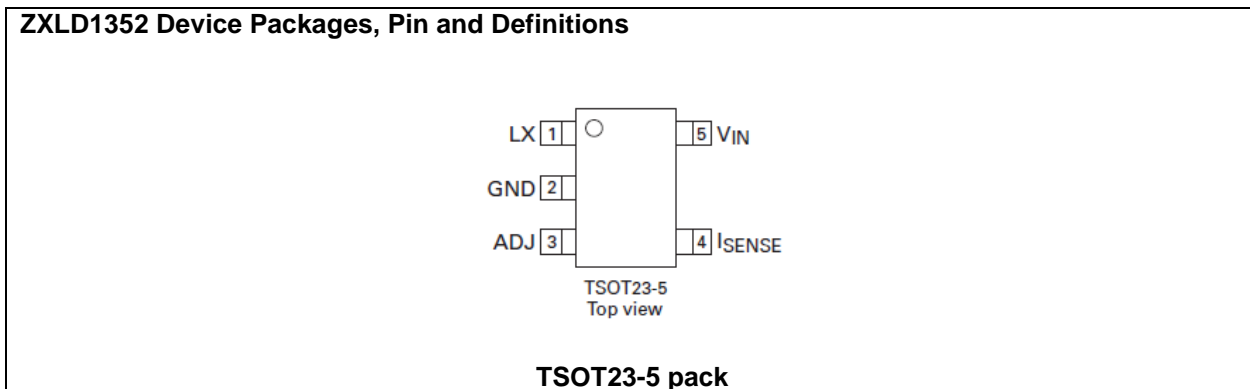

ZXLD1352 Device Pin Definition		
Name	Pin No	Description
LX	1	Drain of NDMOS switch.
GND	2	Ground (0V).
ADJ	3	Internal voltage ref. pin (1.25V) : <ul style="list-style-type: none"> • Leave floating for normal operation. • Connect to GND to turn off output current. • Drive with DC voltage (0.3V to 1.25V) or with PWM signal to adjust output current or.... • Connect a capacitor from this pin to ground to set soft-start time.
ISENSE	4	Connect a sense resistor, R_s , from the ADJ pin to VIN to sense the nominal output current. Nominal $I_{out} = 0.1 / R_s$
VIN	5	Input voltage: 7V to 30V. Decouple to ground with a 1uF or higher ceramic capacitor.

ORDERING INFORMATION

EVALBOARD ORDER NUMBER
ZXLD1352EV1

DEVICE ORDER NUMBER
ZXLD1352E5TA

Please note: Evaluation boards are subject to availability and qualified leads.

ZXLD1352EV1 EVALUATION BOARD REFERENCE DESIGN

The ZXLD1352EV1 is configured to the reference design in Figure 2. The target application is a driver for one or more series-connected 1W white LEDs for torches and other high powered LED driving applications.

The operating voltage is a nominal 24V. For three 1W series-connected LEDs, the voltage can be from 12V minimum to 30V maximum. The nominal current is set at 300mA with a 0.33R sense resistor, R_s . For three series - connected 1-watt LEDs, with a nominal supply of 24V, the ZXLD1352 runs in continuous mode at 545kHz, with a 100uH inductor.

Both DC and PWM dimming can be achieved by driving the ADJ pin. For DC dimming, the ADJ pin may be driven between 0.3V and 1.25V. Driving the ADJ pin below 0.2V will shutdown the output current. For PWM dimming, an external open-collector NPN transistor or open-drain N-channel MOSFET can be used to drive the ADJ pin. The PWM frequency can be low, around 100Hz to 1kHz, or high between 10kHz to 50kHz. C3 should not be fitted on the evaluation board when using the PWM dimming feature. Shorting R1 will connect

the test pin ADJ to device pin ADJ. The capacitor C3 should be around 10nF to decouple high frequency noise at the ADJ pin for DC dimming.

The soft-start time will be nominally 0.1ms without capacitor C3. Adding C3 will increase the soft start time by approximately 0.5ms/nF

For other reference designs or further applications information, please refer to the ZXLD1352 datasheet.

Schematic Diagram

Figure 2 shows the schematic for the ZXLD1352EV1 evaluation board.

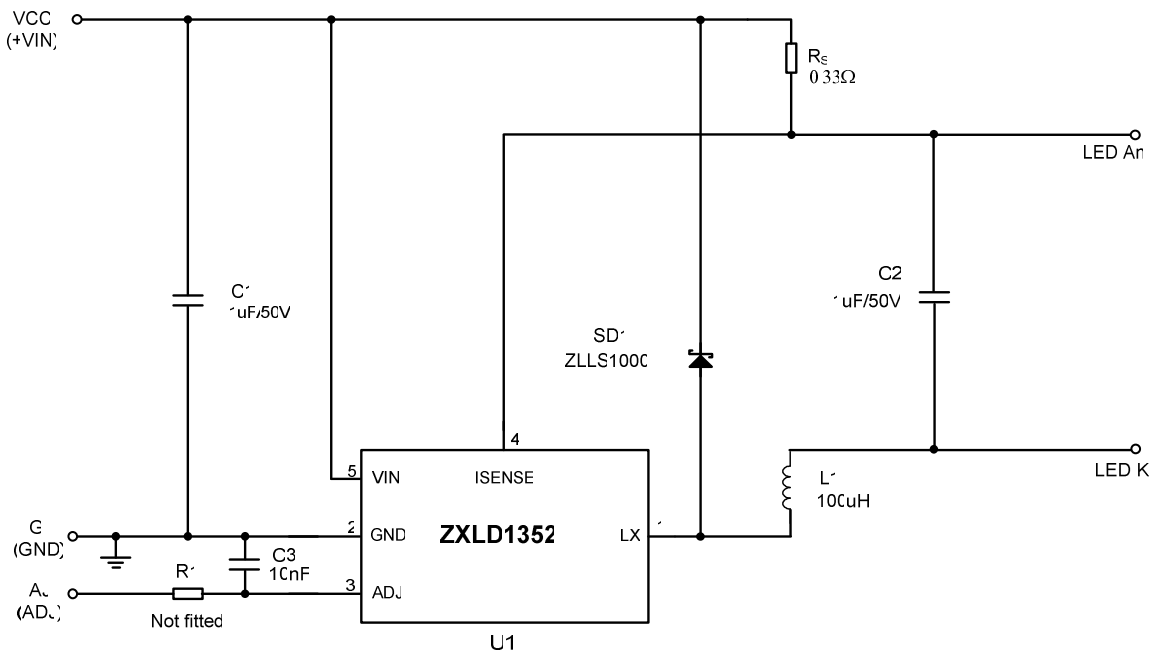

Figure 2: Schematic for the evaluation board ZXLD1352EV1

ZXLD1352 Operation

In normal operation, when voltage is applied at +VIN, the ZXLD1352 internal NDMOS switch is turned on. Current starts to flow through sense resistor Rs, inductor L1, and the LEDs. The current ramps up linearly, and the ramp rate is determined by the input voltage +VIN and the inductor L1. This rising current produces a voltage ramp across Rs. The internal circuit of the ZXLD1352 senses the voltage across Rs and applies a proportional voltage to the input of the internal comparator. When this voltage reaches an internally set upper threshold, the NDMOS switch is turned off. The inductor current continues to flow through Rs, L1, the LEDs, the Schottky diode SD1, and back to the supply rail, but it decays, with the rate of decay determined by the forward voltage drop of the LEDs and the Schottky diode. This decaying current produces a falling voltage at Rs, which is sensed by the ZXLD1352. A voltage proportional to the sense voltage across Rs is applied at the input of the internal comparator. When this voltage falls to the internally set lower threshold, the NDMOS switch is turned on again. This switch-on-and-off cycle continues to provide the average LED current set by the sense resistor Rs. Please refer to the datasheets for the threshold limits, ZXLD1352 internal circuits, electrical characteristics and parameters.

ZXLD1352EV1 Evaluation Board.

Ref	Value	Package	Part Number	Manufacturer	Notes
U1	ZXLD1352	TSOT23-5	ZXLD1352E5TA	Diodes Zetex	DC-DC converter
SD1	40V, 1.16A	SOT23	ZLLS1000	Diodes Zetex	Schottky diode
R _s	0.33R 1%,200ppm	0805	NCST10FR330FTRF	NIC comps.	
R1,R2	Not fitted	0805			Not fitted
C1,C2	1uF, 50V	1206	50V, 1206 X7R C1206C105K5RAC7800 NMC1206X7R105K50F	Kemet NIC comps.	
C3	Not fitted	0805			Not fitted
L1	100uH		MSS6132-104ML NPIS53D101MTRF	Coilcraft NIC comps.	100uH 0.5A rms

Warning: At a nominal 24V operation with 300mA output, the board temperature rises by around 30C from ambient after 30 minutes of operation.

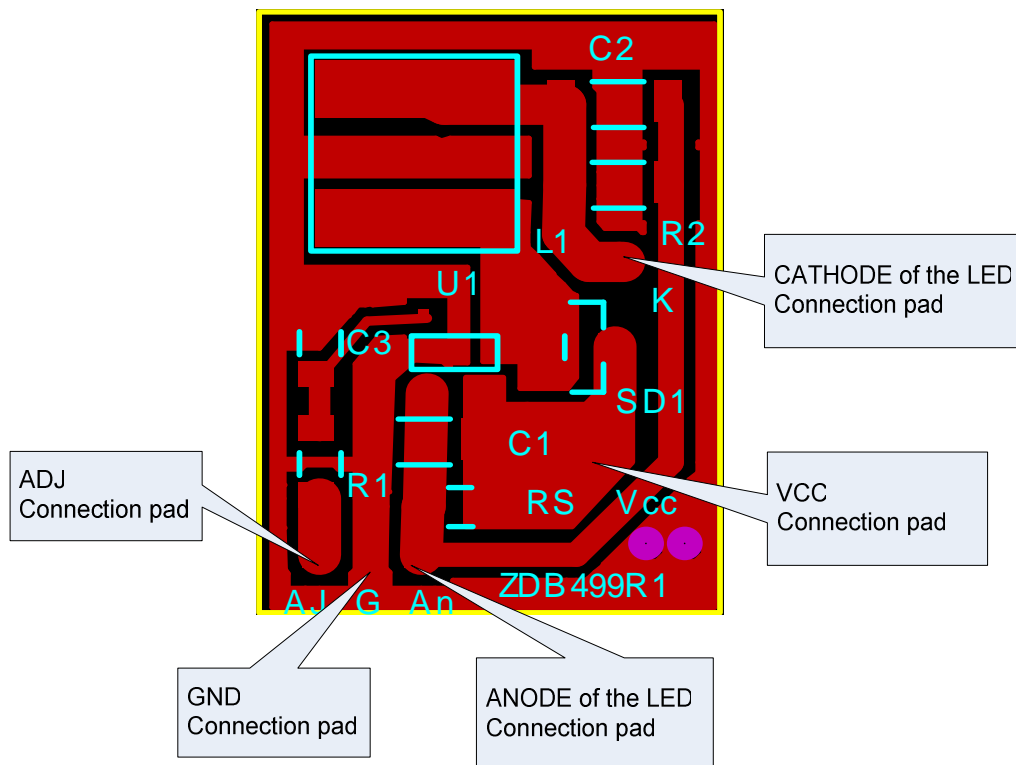

Figure 3: Component layout

ZXLD1352EV1 Connection Point Definition	
Name	Description
VCC (+VIN)	Positive supply voltage. Connect a +24V positive supply to this pin.
G	Supply Ground (0V). Connect supply ground to this pin.
AJ	Internal voltage ref. pin (1.25V). This pin can be used to achieve dimming and soft-start, and for switching the output current off. <ul style="list-style-type: none"> • Leave floating for normal operation. • See 'Other Features' section to achieve dimming and soft-start and for switching the output current off.
An	LED a connects to the ANODE of external LED.
K	LED k connects to the CATHODE of external LED.

ZXDL1352EV1 OPERATION

1. Connect VIN to +24V of the power supply unit (PSU). Connect GND to the power supply ground (0V).
Warning: The board does not feature reverse battery/supply protection.
2. Set the PSU to +24V. (+24V at VIN pin with ref. to the GND pin.)
3. Turn on the PSU.
Warning: Do not stare at the LEDs directly.
4. External LEDs should illuminate and will be regulated nominally at 300mA.
Warning: The LEDs may be hot.

OTHER FEATURES

Dimming

The ZXLD1352 provides three dimming options: DC dimming, high-frequency PWM and low-frequency PWM dimming.

DC Voltage Dimming

1. Switch off the power supply.
2. Solder a link across R1 pads.
3. Fit a 10nF capacitor at C3 to decouple the pin.
4. Drive the ADJ pin on the board with a DC voltage in the range 0.3V to 1.25V.
5. Do not exceed 1.25V, as this represents 100% of the LED current set by Rs. The current will increase in proportion to this voltage. For example, if 2.5V is applied, the current will increase to 200%. That is, the current will be twice the 1.25V rating. For such over-drive of the ADJ pin, the LED and ZXLD1352 are likely to be damaged. The nominal LED current (output current), I_{OUT}, is given by

$$I_{OUT} = 0.08 * V_{ADJ} / R_s \quad \text{where } I_{OUT} = \text{the nominal LED current.}$$

V_{ADJ} = the DC dimming voltage at ADJ pin resistor.
0.08 is the multiplier for the reference voltage on ADJ pin.
R_s = the sense resistor value in ohms.

Do not use a resistor value lower than 0.27Ω

6. The dimming ratio is around 6:1. Note: as the voltage approaches 0.2V on the ADJ pin, the ZXLD1352 will shut down.
7. Follow the 'ZXLD1352EV1 Power Up' sequence.

High Frequency PWM Dimming

1. Switch off the power supply.
2. Solder a link across R1 pads.
3. Ensure C3 is not fitted.
4. Connect a PWM signal to the ADJ pin via an open collector NPN transistor, or an open drain N-channel MOSFET.
5. Alternatively, drive the ADJ pin directly with a PWM signal. However, make sure the PWM signal voltage levels do not violate the ADJ pin voltage rating. Driving the ADJ pin above 1.25V will exceed the maximum set current for the value of Rs and may damage the device or LED.
6. Set the PWM frequency to between 10KHz and 50KHz. The cut-off frequency of the internal filter is 4kHz, and exceeding the 50kHz may cause modulation with the switching regulator.
7. The dimming ratio will be about 6:1, similar to the DC dimming. The nominal LED current (output current), I_{OUT} , is given by

$$I_{OUT} = 0.1 * D / R_s \text{ where } I_{OUT} = \text{the nominal LED current.}$$

R_s = the sense resistor value in ohms.
[Do not use a resistor value lower than 0.27 \$\bar{R}\$](#)
 D = the duty cycle of the PWM dimming frequency.
 0.1V is the nominal sense voltage with ADJ open circuit or set to 1.25V.

Note: The ADJ pin is internally referenced to 1.25V. This pin should be left floating for normal operation without dimming. Please refer to the datasheet for PWM frequency.

8. Follow the 'ZXLD1352EV1 Power Up' sequence.

Low Frequency PWM Dimming

The ZXLD1352 has enhanced performance in terms of PWM dimming resolution, and this can be tested applying the following procedure.

1. Switch off the power supply.
2. Solder a link across R1 pads.
3. Make sure C3 is not fitted.
4. Connect a PWM signal to the ADJ pin via an open collector NPN transistor or an open drain N-channel MOSFET.
5. Alternatively, drive the ADJ pin directly with a PWM signal. However, make sure the PWM signal voltage levels do not violate the ADJ pin voltage rating. Driving the ADJ pin above 1.25V will exceed the maximum set current for the value of Rs and may damage the device or LED
6. The PWM frequency can be low; around 100Hz or up to 1kHz.
7. The ZXLD1352 is now effectively being turned on and off at the PWM frequency. The dimming ratios are in the region of 1000:1, much greater than the DC dimming ratio. The average I LED current (output current), I_{OUT} , is given by

$$I_{OUT} = 0.1 * D / R_s \text{ where } I_{OUT} = \text{the average LED current.}$$

R_s = the sense resistor value in ohms.
[Do not use a resistor value lower than 0.27R](#)
 D = the duty cycle of the PWM dimming frequency.
 0.1V is the nominal sense voltage with ADJ open circuit or set to 1.25V.

8. Follow the 'ZXLD1352EV1 Power Up' sequence.

Soft-start

1. Switch off the power supply.
2. Solder a link across R1 pads.
3. Fit a capacitor at C3 to decouple the pin. The value of C3 will determine the soft-start time setting. Please see the datasheet for calculation of the capacitor value.
4. Follow the 'ZXLD1352EV1 Power Up' sequence.

Switching the output current off

1. Switch off the power supply.
2. Solder a link across R1 pads.
3. Follow the 'ZXLD1352EV1 Power Up' sequence.
4. Connect the ADJ pin to GND to turn off the output current.
5. Follow the 'ZXLD1352EV1 Power Up' sequence. The ZXLD1352 internal switch remains switched off (output current off) whilst the ADJ pin is pulled to GND.

Changing the LED current

1. Switch off the power supply.
2. Remove Rs.
3. Calculate and fit a new sense resistor, Rs, the value of which is based on the required LED current without dimming. Rs can be calculated using following equation :

$R_s = 0.1V/I_{OUT}$ where I_{OUT} = the LED current.
 Rs = the sense resistor value in ohms.
Do not use a resistor value lower than 0.27R
 0.1V is the nominal sense voltage with ADJ open circuit or set to 1.25V.

4. Follow the 'ZXLD1352EV1 Power Up' sequence.

PERFORMANCE

The system efficiency depends on the sense resistor, supply voltage, switching inductor and the number of 1W LEDs connected in series.

The graph below shows the efficiency with a 0.33R sense resistor R_s , and a 100uH inductor, for 1 to 3 series connected 1W LEDs.

With a 24V supply, the switching frequency is typically 545kHz for three series-connected 1-watt LEDs and 300kHz for a single 1-watt LED.

With a 12V supply, the switching frequency is typically 160kHz for three series-connected 1-watt LEDs and 280kHz for a single 1-watt LED

The detailed performance information for the device can be found in the datasheets.

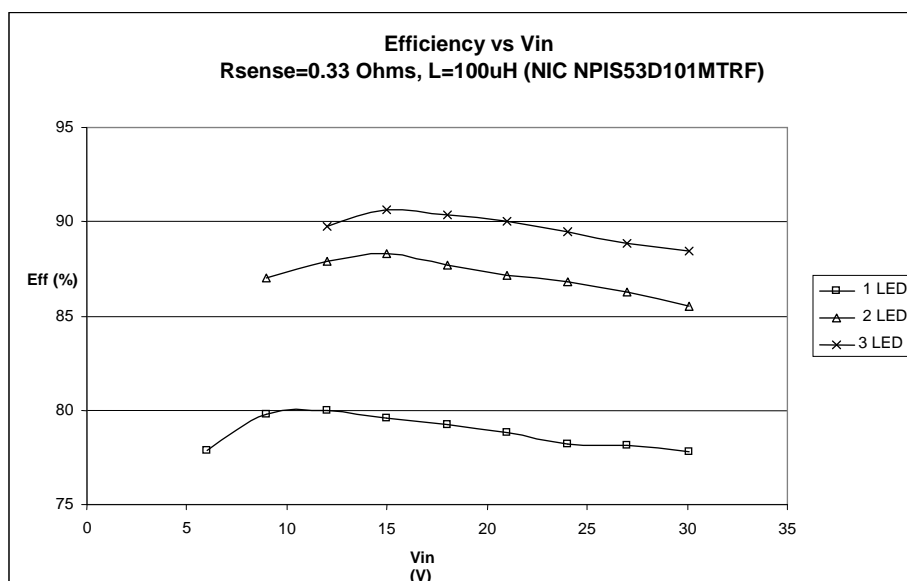

Figure 6: Efficiency vs supply voltage

IMPORTANT NOTICE

Diodes Incorporated and its subsidiaries reserve the right to make modifications, enhancements, improvements, corrections or other changes without further notice to any product herein. Diodes Incorporated does not assume any liability arising out of the application or use of any product described herein; neither does it convey any license under its patent rights, nor the rights of others. The user of products in such applications shall assume all risks of such use and will agree to hold Diodes Incorporated and all the companies whose products are represented on our website, harmless against all damages. Diodes Incorporated does not warrant or accept any liability whatsoever in respect of any parts purchased through unauthorized sales channels.

LIFE SUPPORT

Diodes Incorporated products are specifically not authorized for use as critical components in life support devices or systems without the express written approval of the Chief Executive Officer of Diodes Incorporated. As used herein:

- A. Life support devices or systems are devices or systems which:
1. are intended to implant into the body, or
 2. support or sustain life and whose failure to perform when properly used in accordance with instructions for use provided in the labeling can be reasonably expected to result in significant injury to the user.
- B. A critical component is any component in a life support device or system whose failure to perform can be reasonably expected to cause the failure of the life support device or to affect its safety or effectiveness.

Sales offices**The Americas**

3050 E. Hillcrest Drive
Westlake Village,
CA 91362-3154
Tel: (+1) 805 446 4800
Fax: (+1) 805 446 4850

Europe

Kustermannpark
Balanstraße 59,
D-81541 München
Germany
Tel: (+49) 894 549 490
Fax: (+49) 894 549 4949

Taiwan

7F, No. 50,
Min Chuan Road
Hsin-Tien
Taipei, Taiwan
Tel: (+886) 289 146 000
Fax: (+886) 289 146 639

Shanghai

Rm. 606, No.1158
Changning Road
Shanghai, China
Tel: (+86) 215 241 4882
Fax (+86) 215 241 4891

Shenzhen

Room A1103-04,
ANLIAN Plaza, #4018
Jintian Road
Futian CBD,
Shenzhen, China
Tel: (+86) 755 882 849 88
Fax: (+86) 755 882 849 99

Korea

6 Floor, Changhwa B/D,
1005-5 Yeongtong-dong,
Yeongtong-gu, Suwon-si,
Gyeonggi-do, Korea 443-813
Tel: (+82) 312 731 884
Fax: (+82) 312 731 885