

ZXGD3102EV1 USER GUIDE

Performance

- Two power inputs, -30V to -75V, 0 to 5A
- One power output, wired-OR
- Fast turn-off: 150ns from input short-circuit with 4A load
- Turn-on time typ 1 μ s
- Full reverse polarity protection (150V blocking)
- Voltage drop 68mV at 2A, 195mV at 5A
- Ambient temperature range -40 to 105°C

Description

This evaluation circuit demonstrates a shared power system using low-side wired-OR switching for two -48V 5A supplies, and uses two ZXGD3102 Active Or-ing Controllers. The circuit is suitable for Telecom and other shared power systems.

Each ZXGD3102 drives a MOSFET configured as a replacement for a Schottky diode. The ZXGD3102 is particularly optimized for wired-OR circuits providing a significantly lower voltage drop than a Schottky diode.

In the steady-state condition, the circuit demonstrates current sharing between two input powers supplies of approximately equal voltage.

During change-over or hot-swapping, a turn-off time of typically 150ns and a turn-on time of approximately 1 μ s prevents shoot-through between input power supplies, while allowing a moderate capacitor reservoir to support the load demand during the transient.

Ordering Information

Order Number
ZXGD3102EV1

The construction is a double-sided FR4 printed circuit board with 2oz/sq ft copper (35 μ m).

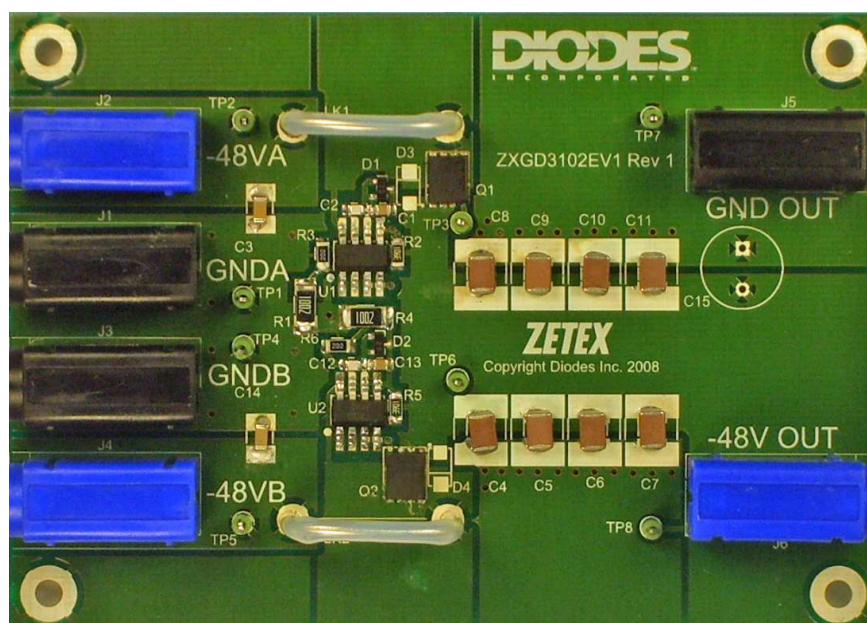

Schematic

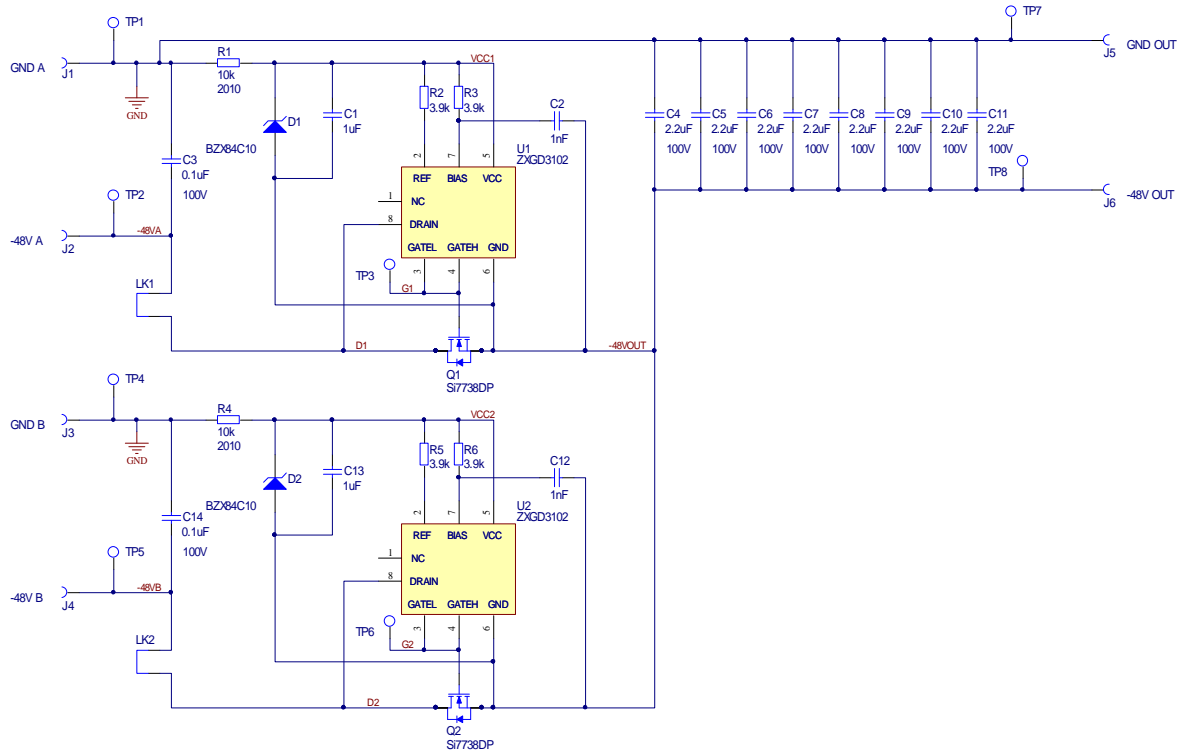

PCB Layout

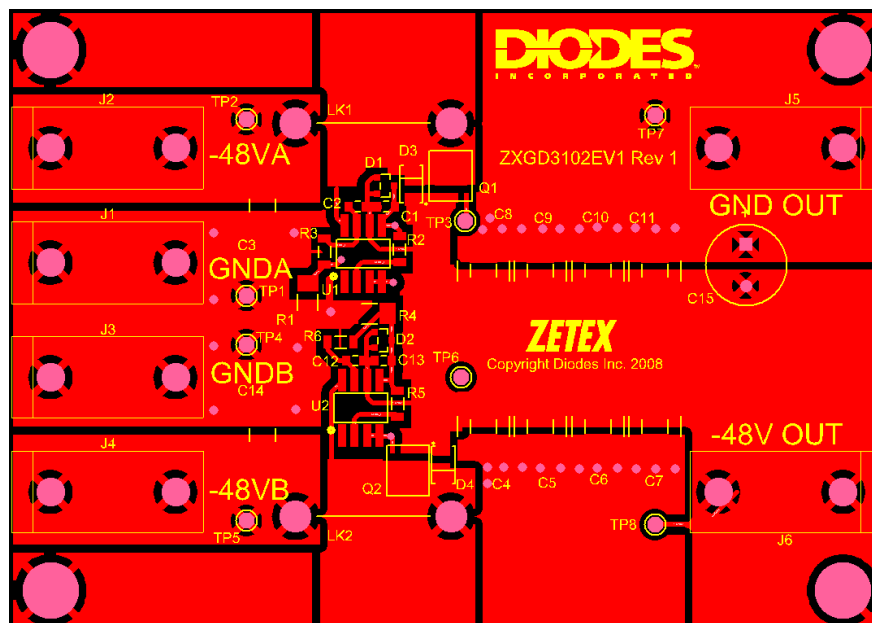

Top Side

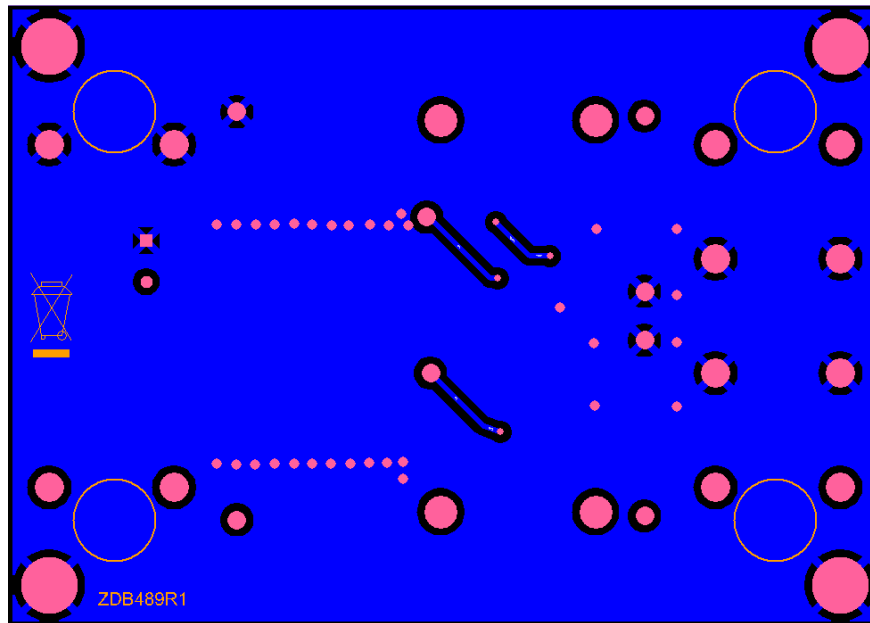

Bottom side

Parts List

Count	Designator	Description	Package	Manufacturer	Part Number
2	C1, C13	Capacitor SMD, 1uF 16V X7R	0805	Murata	GRM21BR71C105KA01L
2	C2, C12	Capacitor SMD, 1nF 50V NPO	0805	Kemet	C0805C102J5GAC
2	C3, C14	Capacitor, SMD, 0.1uF 100V X7R	1206	Kemet	C1206C104K1RAC
8	C4, C5, C6, C7, C8, C9, C10, C11	Capacitor, SMD, 2.2uF 100V X7R	1812	Murata	GRM43ER72A225KA01L
2	D1, D2	Zener Diode BZX84C10	SOT23	Diodes	BZX84C10
2	Q1, Q2	150V N-Channel MOSFET, Si7738DP	POWER PAK SO8	Vishay	Si7738DP
2	R1, R4	Resistor, SMD, 10k	2010		
4	R2, R3, R5, R6	Resistor, SMD, 3.9k	1206		
2	U1, U2	Active OR-ing Controller, ZXGD3102	SM8	Diodes	ZXGD3102T8

I/O and Test points

Count	Designator	Description	Function	Manufacturer	Part Number
1	J1 (GNDA)	Socket 4mm horizontal, black	Input A Ground (+ve terminal)	Deltron	571-0100
1	J2 (-48VA)	Socket 4mm horizontal, blue	Input A -48V (-ve terminal)	Deltron	571-0200
1	J3 (GNDB)	Socket 4mm horizontal, black	Input B Ground (+ve terminal)	Deltron	571-0100
1	J4 (-48VB)	Socket 4mm horizontal, blue	Input B -48V (-ve terminal)	Deltron	571-0200
1	J5 (GND OUT)	Socket 4mm horizontal, black	Output Ground (+ve terminal)	Deltron	571-0100
1	J6 (-48V OUT)	Socket 4mm horizontal, blue	Output -48V (-ve terminal)	Deltron	571-0200
1	LK1	Current Probe Link	Monitor Channel A MOSFET drain current using Tek current probe		
1	LK2	Current Probe Link	Monitor Channel B MOSFET drain current using Tek current probe		
1	TP2	Loop test point, 1.5mm, Green	Monitor Channel A input voltage	Hughes	200-208
1	TP5	Loop test point, 1.5mm, Green	Monitor Channel B input voltage	Hughes	200-208
1	TP3	Loop test point, 1.5mm, Green	Monitor Channel A MOSFET gate voltage	Hughes	200-208
1	TP6	Loop test point, 1.5mm, Green	Monitor Channel B MOSFET gate voltage	Hughes	200-208
1	TP8	Loop test point, 1.5mm, Green	Monitor Output voltage	Hughes	200-208
3	TP1, TP4, TP7	Loop test point, 1.5mm, Green	Monitor Ground reference	Hughes	200-208

Recommended Operating Conditions

Symbol	Parameter	Min	Max	Units
VA or VB	Active Input voltage A or B	-75	-30	V
VA or VB	Inactive Input Voltage A or B	-75	+75	V
IOUT	Output Load Current	0	5	A
T _A	Operating Ambient Temperature	-40	105	°C

Quick Start Guide

DC Test

1. Set a bench dual power supply to current limit at 2.5A on both outputs but do not switch on.
2. Connect one power supply (A) to the input -48VA with respect to GNDA (+ve).
3. Connect the other supply (B) to the input -48VB with respect to GNDB.
4. Connect an electronic load or a passive adjustable load resistance of approximately 12 ohms between GND OUT and -48V OUT, connected in series with a multimeter set to measure up to 5A.
5. Set power supply A to less than 1V and switch on. Gradually increase the supply voltage to 48.5V and adjust the load to a current of 2A.
6. Set power supply B to 48.0V and switch on. Observe that the current is drawn from supply A and no significant current is drawn from supply B.
7. Using a second multimeter, measure the voltage drop between the input A voltage at TP2 and the output at TP8. This is typically 68mV (80 mV maximum).
8. Switch off and increase the current limit of both supplies both to 4.5A. Switch on and increase the load current to 4A. The input-output voltage drop is seen to be typically 140mV (200mV maximum).

Transient Test at 2 A

9. Reduce the load current to 2A and reduce the current limit on both supplies to 2.5A.
10. Switch off supply A. Observe that full current is drawn from supply B. Switch on supply A.
11. Arrange convenient short circuit points across supply A, using a short length (about 15 cm) of 6A equipment wire (32x0.2mm or 1sq. mm minimum). **CAUTION:** a bright spark is produced, which is safe at this power level, but fingers should be kept away from the contact points.
12. Connect an oscilloscope via a probe to the test point J2 with respect to J1, and set the gain to 20V/div, DC coupled. Set the oscilloscope so that it will trigger on the positive going edge at J2, at a level of about 10V above the -48V input level. Set the timebase to 1µs/div.
13. Fit a current probe to LK1, connected to a second channel of the oscilloscope, set to a gain of 200mV/div, DC coupled. Set the current probe switch to 10mA/mV.
14. Short out supply A and observe the oscilloscope waveform. The oscilloscope display is shown as in the first of the typical waveforms given below.
15. Further waveforms are shown for alternative measurement connections. Take care, when measuring with respect to the output, to transfer both oscilloscope ground return leads to the same potential.

Note that, to capture the fast waveforms, it has been found that the scope probes need short signal and ground connections of about 2cm or less from the PCB test points.

Suitable Test Equipment

Count	Description	Manufacturer	Part Number
1	Dual Bench Power Supply, 60V 20A	Thurlby Thandar	CPX400A
2	Digital Multimeter	Fluke	179
1	Oscilloscope, 4 Channel Digital Storage, 200 MHz Single Shot BW	Tektronix	TDS2024
1	AC Current Probe	Tektronix	P6021
1	Resistive load or Electronic Load, 0 to 4A		

Typical Waveforms

These waveforms show the response to a short circuit across the power supply at input A. The voltage at Input A is -48.5V. The voltage at Input B is -48.0V. Waveforms 1 to 5 show the response for a load current of 2.1A. Waveforms 6 to 10 show the response for a load current of 4.1A.

It can be seen that there is a moderate high frequency ring on the MOSFET gate voltage and drain current waveforms. This is caused by the inductance of the current loop. Further tests, not depicted here, have shown that the ring is reduced significantly by shorting out the current loop with a low inductance connection. The ring is further reduced by adding an additional 0.1µF, X7R 100V surface mount capacitor from each MOSFET drain to ground near each MOSFET.

Stability is also improved by adding a resistor in series with the gate. This is not essential but a value of 4.7 to 10 ohms is recommended when using the Si7738 MOSFET.

Waveform 1

Load current = 2.1A.
Channel A Input Voltage and Current

This shows the partial collapse of the input A voltage. Also the input A current (using an AC probe) is reduced to zero (2A step) after a brief period of reverse current (Approx. 7.5A peak)

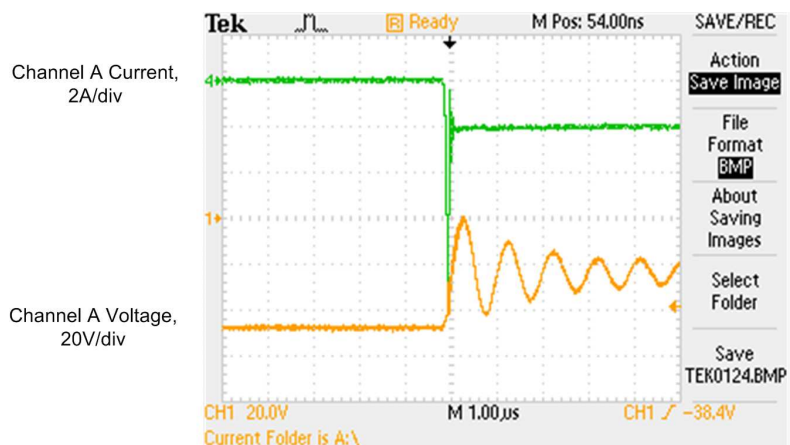

Waveform 2

Load current = 2.1A.
Channel A Input Voltage and Current, faster timebase

As Waveform 1 but the expanded time base shows that the transient lasts approximately 150ns.

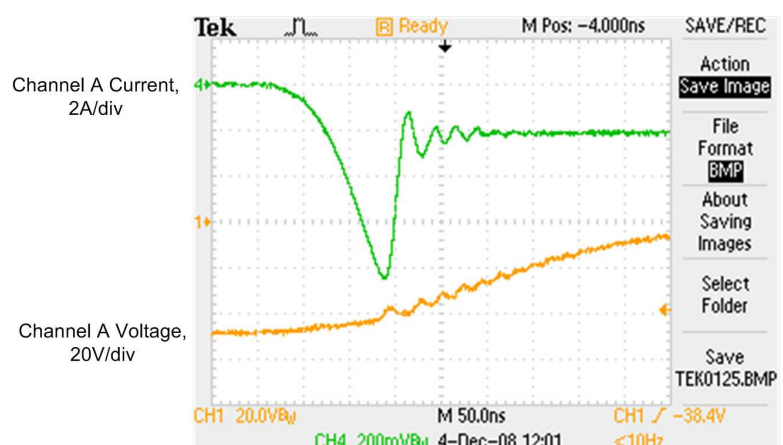

Waveform 3
Load current = 2.1A.
Channel A Input Voltage and
Output Voltage

This shows the small disturbance on the output

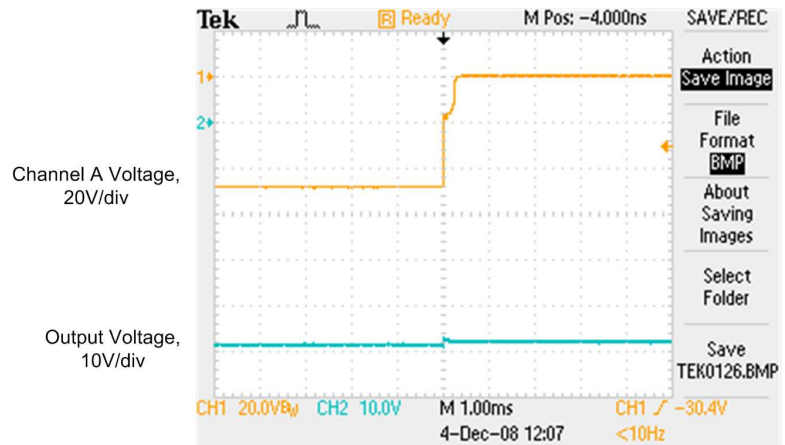

Waveform 4
Load current = 2.1A.
Channel A Input Voltage wrt Output, Channel A
Current and Channel A
Gate-Source Voltage

This shows the turn-off response of Channel A: the positive going step in Q1 drain-source voltage, Q1 gate-source turn-off transient and the drain current.

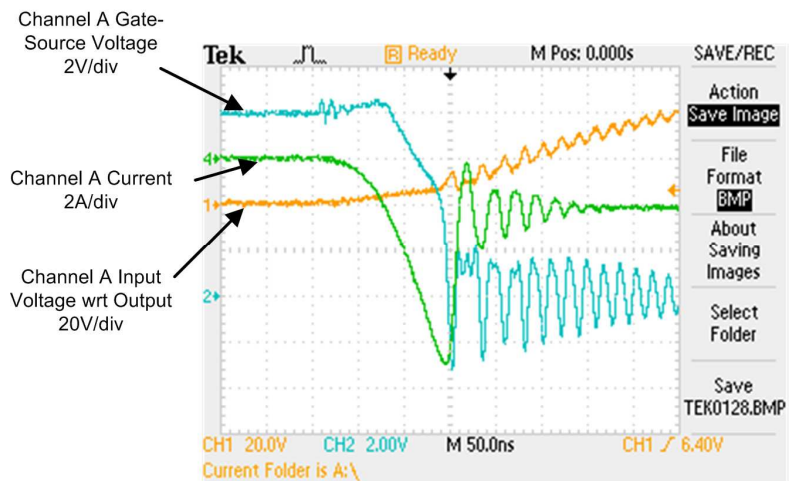

Waveform 5
Load current = 2.1A.
Channel A Input Voltage wrt Output, Channel B Current
and Channel B Gate-Source Voltage

This shows the turn-on response of Channel B, including Q2 gate-source voltage and the drain current. It can be seen that initially Q2 body diode turns on after about 1 μ s, then the MOSFET turns on in about 8 μ s

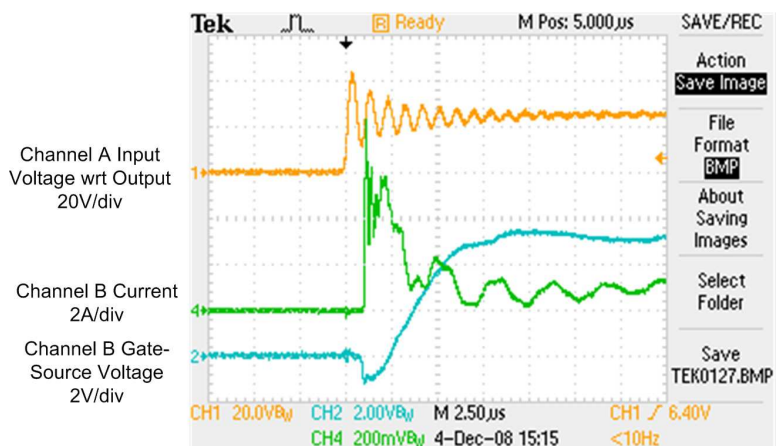

Waveform 6
Load Current = 4.1A.
Channel A Input Voltage and Current

This shows the partial collapse of the input A voltage. Also the input A current (using an AC probe) is reduced to zero (4A step) after a brief period of reverse current (Approx. 8.5A peak)

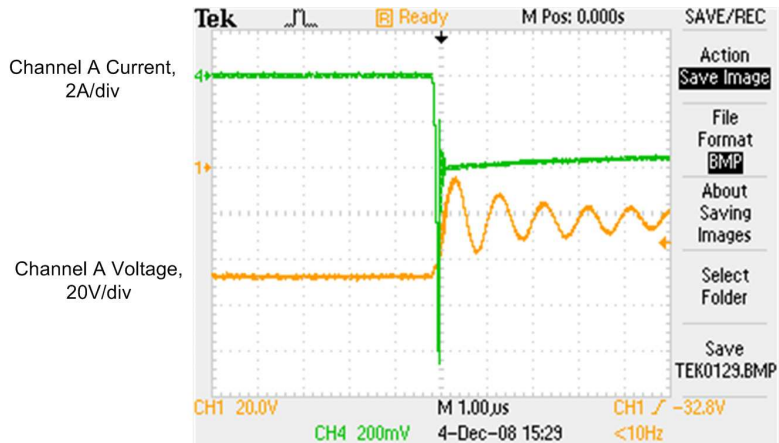

Waveform 7
Load Current = 4.1A.
Channel A Input Voltage and Current, expanded timebase

As Waveform 6 but the expanded time base shows that the transient lasts approximately 150ns.

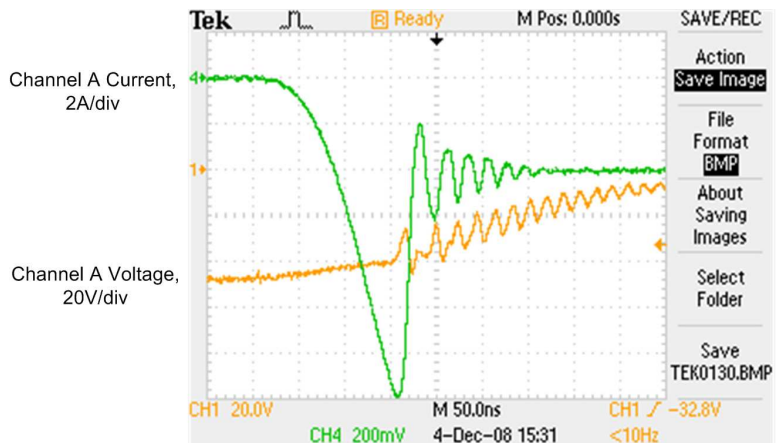

Waveform 8
Load Current = 4.1A.
Channel A Input Voltage and Output Voltage

This shows the small disturbance on the output

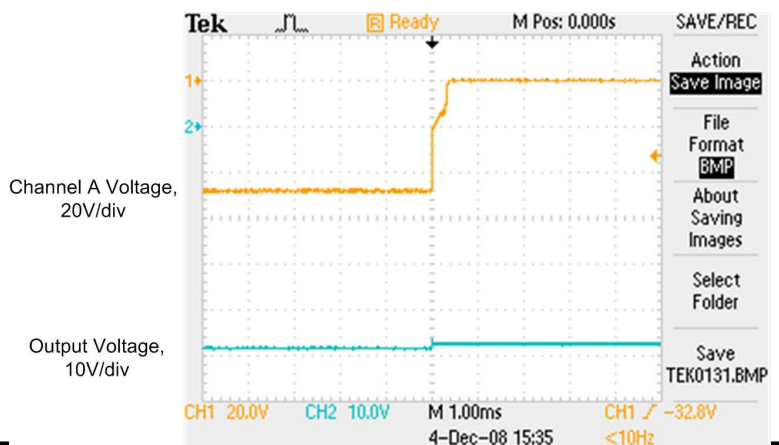

Waveform 9
Load Current = 4.1A.
Channel A Input Voltage wrt Output, Channel A Current and Channel A Gate-Source Voltage

This shows the turn-off response of Channel A: the positive going step in Q1 drain-source voltage, Q1 gate-source turn-off transient and the drain current.

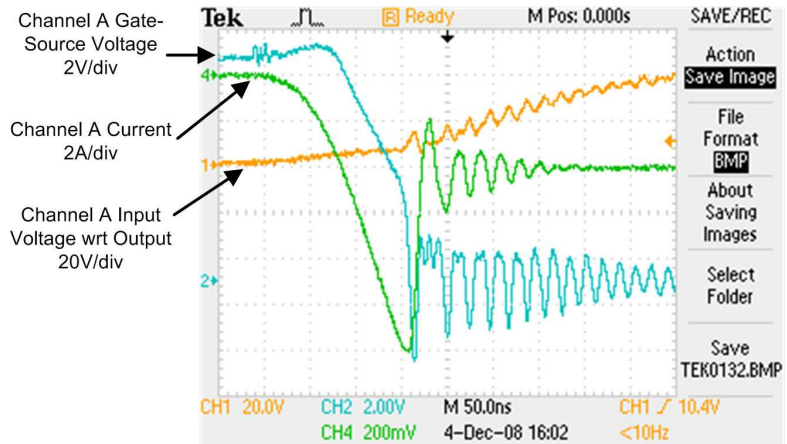

Waveform 10
Load Current = 4.1A.
Channel A Input Voltage wrt Output, Channel B Current and Channel B Gate-Source Voltage

This shows the turn-on response of Channel B, including Q2 gate-source voltage and the drain current. It can be seen that initially Q2 body diode turns on after about 1 μ s, then the MOSFET turns on in about 8 μ s

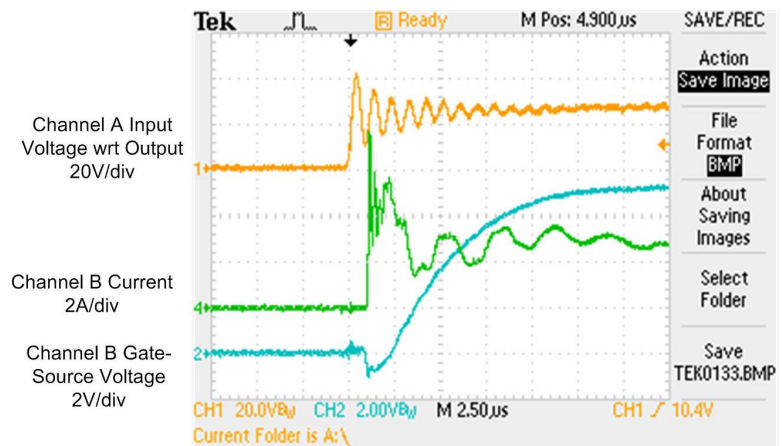

Definitions
Product change

Diodes Incorporated reserves the right to alter, without notice, specifications, design, price or conditions of supply of any product or service. Customers are solely responsible for obtaining the latest relevant information before placing orders.

Applications disclaimer

The circuits in this design/application note are offered as design ideas. It is the responsibility of the user to ensure that the circuit is fit for the user's application and meets with the user's requirements. No representation or warranty is given and no liability whatsoever is assumed by Diodes Inc. with respect to the accuracy or use of such information, or infringement of patents or other intellectual property rights arising from such use or otherwise. Diodes Inc. does not assume any legal responsibility or will not be held legally liable (whether in contract, tort (including negligence), breach of statutory duty, restriction or otherwise) for any damages, loss of profit, business, contract, opportunity or consequential loss in the use of these circuit applications, under any circumstances.

Life support

Diodes Zetex products are specifically not authorized for use as critical components in life support devices or systems without the express written approval of the Chief Executive Officer of Diodes Incorporated. As used herein:

- A. Life support devices or systems are devices or systems which:
1. are intended to implant into the body
- or
2. support or sustain life and whose failure to perform when properly used in accordance with instructions for use provided in the labeling can be reasonably expected to result in significant injury to the user.
- B. A critical component is any component in a life support device or system whose failure to perform can be reasonably expected to cause the failure of the life support device or to affect its safety or effectiveness.

Reproduction

The product specifications contained in this publication are issued to provide outline information only which (unless agreed by the company in writing) may not be used, applied or reproduced for any purpose or form part of any order or contract or be regarded as a representation relating to the products or services concerned.

Terms and Conditions

All products are sold subjects to Diodes Inc. terms and conditions of sale, and this disclaimer (save in the event of a conflict between the two when the terms of the contract shall prevail) according to region, supplied at the time of order acknowledgement.

For the latest information on technology, delivery terms and conditions and prices, please contact your nearest Diodes sales office.

Quality of product

Diodes Zetex Semiconductors Limited is an ISO 9001 and TS16949 certified semiconductor manufacturer.

To ensure quality of service and products we strongly advise the purchase of parts directly from Zetex Semiconductors or one of our regionally authorized distributors. For a complete listing of authorized distributors please visit: www.zetex.com or www.diodes.com.

Diodes Zetex Semiconductors does not warrant or accept any liability whatsoever in respect of any parts purchased through unauthorized sales channels.

ESD (Electrostatic discharge)

Semiconductor devices are susceptible to damage by ESD. Suitable precautions should be taken when handling and transporting devices. The possible damage to devices depends on the circumstances of the handling and transporting, and the nature of the device. The extent of damage can vary from immediate functional or parametric malfunction to degradation of function or performance in use over time. Devices suspected of being affected should be replaced.

Green compliance

Diodes Zetex Semiconductors is committed to environmental excellence in all aspects of its operations which includes meeting or exceeding regulatory requirements with respect to the use of hazardous substances. Numerous successful programs have been implemented to reduce the use of hazardous substances and/or emissions.

All Diodes Zetex components are compliant with the RoHS directive, and through this it is supporting its customers in their compliance with WEEE and ELV directives.

Product status key:

"Preview"	Future device intended for production at some point. Samples may be available
"Active"	Product status recommended for new designs
"Last time buy (LTB)"	Device will be discontinued and last time buy period and delivery is in effect
"Not recommended for new designs"	Device is still in production to support existing designs and production
"Obsolete"	Production has been discontinued

Datasheet status key:

"Draft version"	This term denotes a very early datasheet version and contains highly provisional information, which may change in any manner without notice.
"Provisional version"	This term denotes a pre-release datasheet. It provides a clear indication of anticipated performance. However, changes to the test conditions and specifications may occur, at any time and without notice.
"Issue"	This term denotes an issued datasheet containing finalized specifications. However, changes to specifications may occur, at any time and without notice.

Sales offices**The Americas**

3050 E. Hillcrest Drive
Westlake Village,
CA 91362-3154
Tel: (+1) 805 446 4800
Fax: (+1) 805 446 4850

Europe

Kustermannpark
Balanstraße 59,
D-81541 München
Germany
Tel: (+49) 894 549 490
Fax: (+49) 894 549 4949

Taiwan

7F, No. 50,
Min Chuan Road
Hsin-Tien
Taipei, Taiwan
Tel: (+886) 289 146 000
Fax: (+886) 289 146 639

Shanghai

Rm. 606, No.1158
Changning Road
Shanghai, China
Tel: (+86) 215 241 4882
Fax (+86) 215 241 4891

Shenzhen

Room A1103-04,
ANLIAN Plaza, #4018
Jintian Road
Futian CBD,
Shenzhen, China
Tel: (+86) 755 882 849 88
Fax: (+86) 755 882 849 99

Korea

6 Floor, Changhwa B/D,
ANLIAN Plaza, #4018
Yeongtong-gu, Suwon-si,
Gyeonggi-do, Korea 443-813
Tel: (+82) 312 731 884
Tel: (+82) 312 731 885