

ZXCT1107EV1 USER GUIDE

Performance

- **Current Monitor with wide supply range: 2.5V to 36V**
- **Demonstrates high-side current monitoring up to 4A**
- **Resistors on PCB set sense voltage and voltage gain**
- **Ambient temperature range -40°C to +125°C**

Ordering Information

Order Number
ZXCT1107EV1

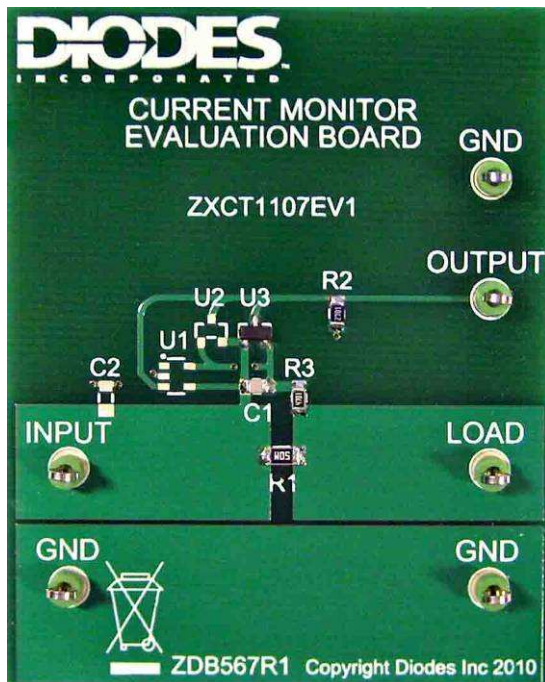

Introduction

The ZXCT1107EV1 evaluation circuit can simply be used to demonstrate the ZXCT1107 Current Monitor integrated circuit which is suitable for a wide range of power systems including automotive, industrial and white goods applications as well as portable and battery management systems.

The PCB is designed to accept one of three different current monitor products, the ZXCT1110 (U1), ZXCT1109 (U2) or ZXCT1107 (U3).

In this case the ZXCT1107 is fitted, but if desired, using conventional lab soldering and de-soldering techniques, this device can be removed and an alternative device fitted.

The ZXCT1107 provides an output voltage proportional to the current in an external load from two external resistors, a sense resistor and a gain set resistor, both are included on this PCB. This enables rapid evaluation of the ZXCT1107 for end user product design.

The construction is a double-sided FR4 printed circuit board, 63.5 x 50.8 x 1.6 mm with 2oz/sq ft copper (70µm).

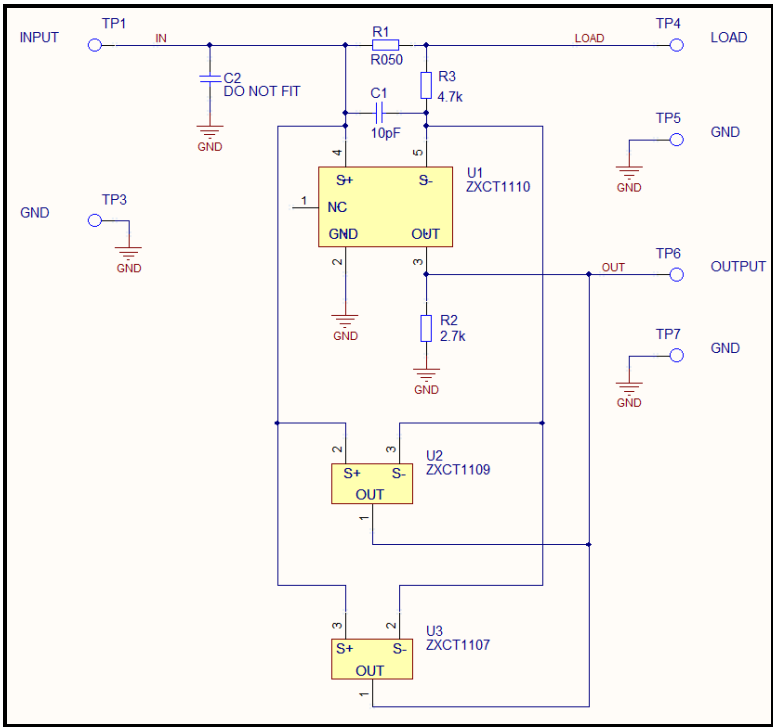

Fig. 1 – ZXCT1107EV1 Schematic

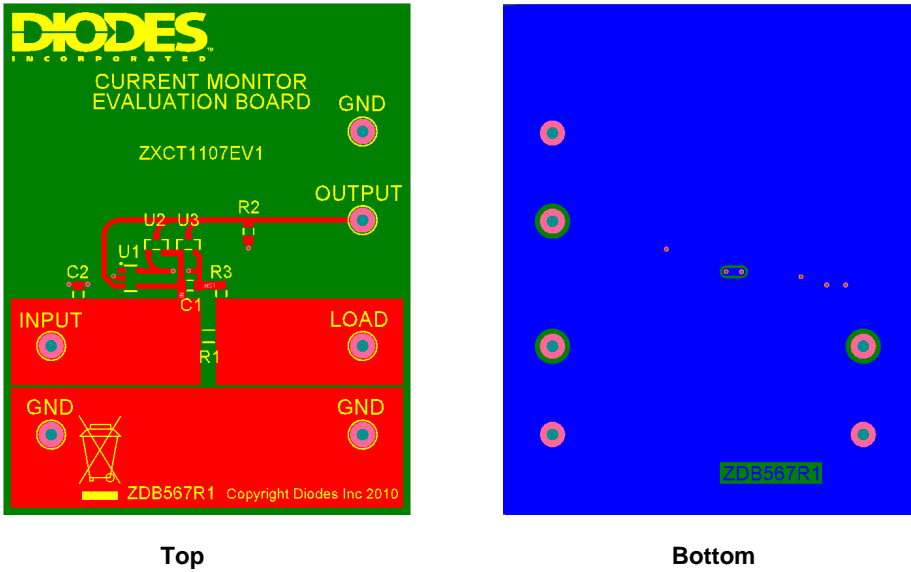

Fig. 2 – ZXCT1107EV1 PCB Layout

Symbol	Parameter	Min	Max	Units
V _{in}	Input Voltage	2.5	36	V
T _A	Operating Ambient Temperature	-40	125	°C

Table 1 – Recommended Operating Conditions

Count	Designator	Description	Package	Manufacturer	Part Number
1	C1	Capacitor SMD, 10pF 100V COG	0805	generic	
0	C2	NOT FTTED			
1	R1	Resistor, SMD, 0R05 1% 500mW 100ppm/ °C	1206	generic	Farnell 109-9913
1	R2	Resistor, SMD, 2.7k 1% 125mW, 250ppm/°C	0805	various	
1	R3	Resistor, SMD, 4.7k 1% 125mW, 250ppm/°C	0805	various	
0	U1	NOT FTTED			
0	U2	NOT FTTED			
1	U3	ZXCT1107	SOT23	Diodes	ZXCT1107SA-7

Table 2 – ZXCT1107EV1 Parts List

Count	Designator	Description	Function	Manufacturer	Part Number
1	TP1	Loop Terminal, 2.15mm, green	Input	Hughes	100-108
1	TP3	Loop Terminal, 2.15mm, green	Ground	Hughes	100-108
1	TP4	Loop Terminal, 2.15mm, green	Load	Hughes	100-108
1	TP5	Loop Terminal, 2.15mm, green	Ground	Hughes	100-108
1	TP6	Loop Terminal, 2.15mm, green	Output	Hughes	100-108
1	TP7	Loop Terminal, 2.15mm, green	Ground	Hughes	100-108

Table 3 – ZXCT1107EV1 I/O and Test Points

Detailed Description

As can be seen from the test setup in Figure 3, the ZXCT1107EV1 is designed to connect a power supply between test points TP1 and TP3, a load and DMM between test points TP4 and TP5, and a DMM to measure the output voltage between test points TP6 and TP7.

The sense resistor is $R1=50m\Omega$ (+/-1%) such that a load current of 2A produces a nominal sense voltage input to the ZXCT1107 of 100mV. From the datasheet, a sense input of 100mV produces a nominal output current of 408uA (+/- 3.4% at 25°C).

The preferred value of $R2=2.7k\Omega$ (+/-1%) will therefore provide a nominal output voltage between TP6 and TP7 of **1.102V**, giving a total voltage output error of **+/-5.4%** for the ZXCT1107EV1 circuit for a 2A load.

As also described in the datasheet, resistor R3 provides S- input protection and together with C1 provides attenuation of possible load generated EMC that might affect the IC input bias conditions.

Quick Start Guide

Suitable test equipment is given in the Table 4.

1. Set the power supply to 10.0V but do not switch on. Set the current limit to 5.0A.
2. Connect up the ZXCT1107EV1 board to the equipment as in **Figure 3** below. Set DMM1 to measure DC voltage. Set DMM2 to measure DC current.
3. Set the electronic load to draw a current of 2A or connect the 5Ω load resistor.
4. Switch on the power supply and adjust the input voltage or the electronic load until DMM2 reads to 2.00A.
5. DMM1 reads the output voltage and should read between **1.042V** and **1.161V** given the total circuit errors of **+/-5.4%** for 100mV sense input voltage.
6. Using an electronic load from zero to 4A load the measurements can be repeated to evaluate the circuit output voltage linearity & errors across the specified input voltage range.
7. Switch off the supply and remove the test connections. This concludes the demonstration.

Figures 4 to 6 demonstrate the product capability and possible V_{S+} errors (refer to datasheet).

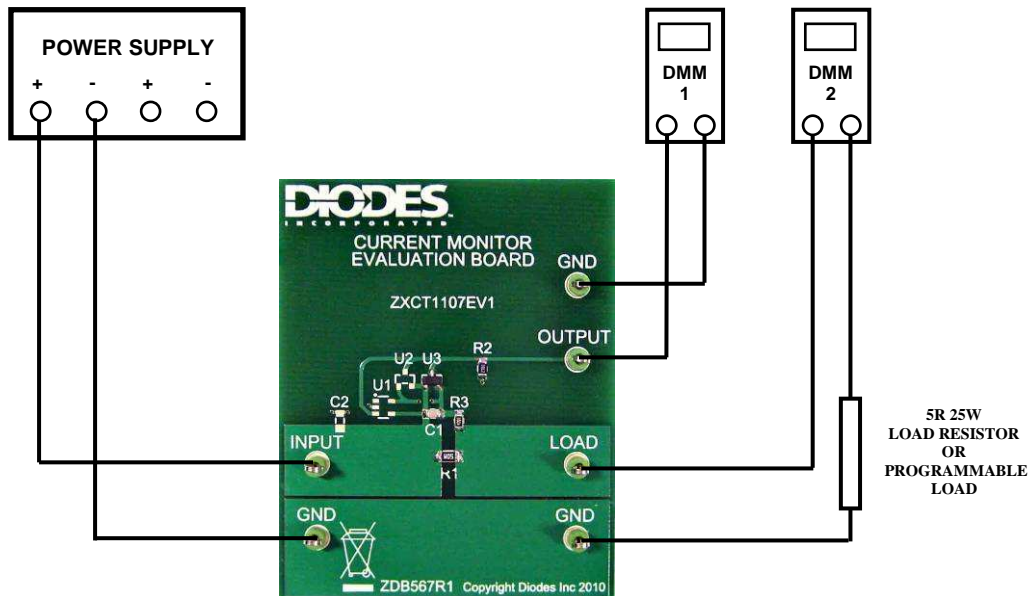

Fig. 3 – ZXCT1107EV1 Demonstration Setup

Count	Description	Manufacturer	Part Number
1	Adjustable Dual PSU 35V / 4A	TTi	354D
2	DMM	Fluke	179
1	Load resistor, 5 ohms ± 5%, 25W up to 2A or Electronic Load up to 4A	Welwyn TTi – 80V/80A/300W or Kikusui – 150V/15A/75W	WH25 5R JI LD300 PLZ70UA & PLZ30F

Table 4 – Suitable Test Equipment

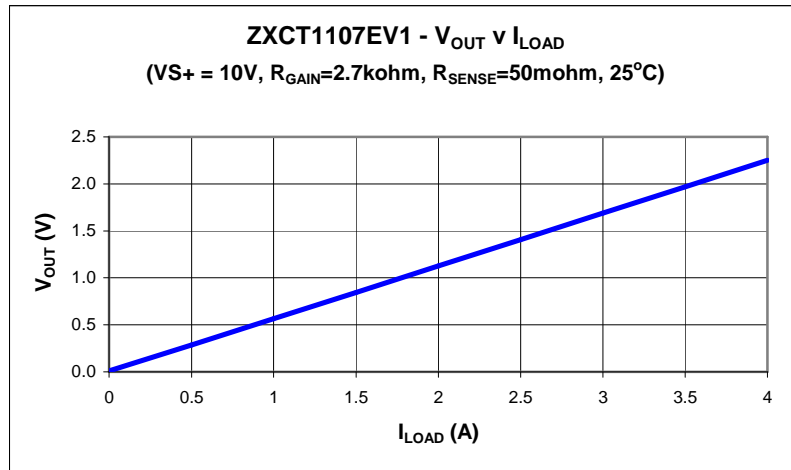

Fig. 4 – ZXCT1107EV1: V_{OUT} v I_{LOAD} @ $V_{S+} = 10V$

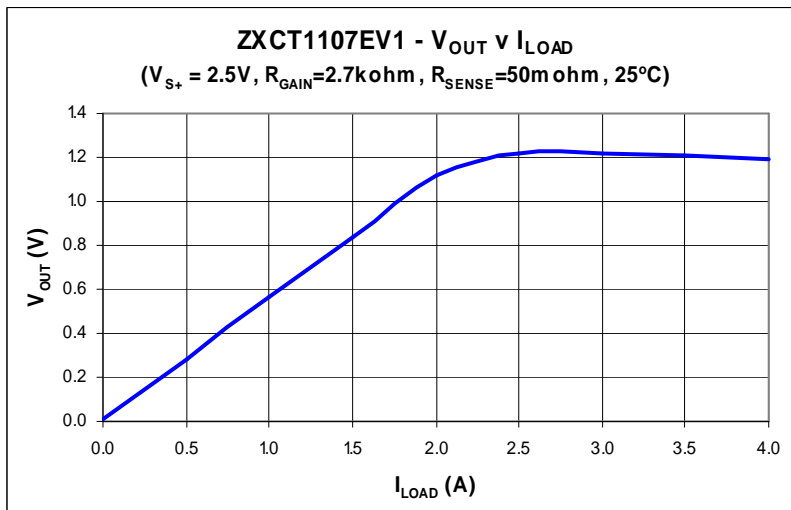

Fig. 5 – ZXCT1107EV1: V_{OUT} v I_{LOAD} @ $V_{S+} = 2.5V$

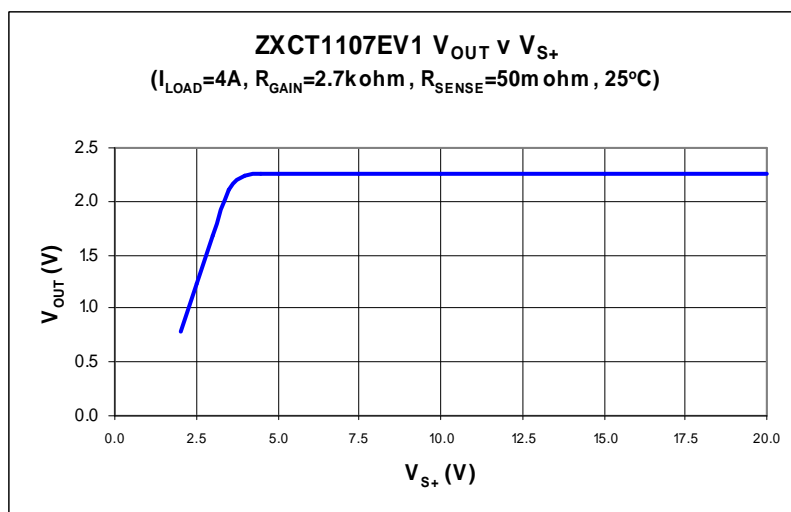

Fig. 6 – ZXCT1107EV1: V_{OUT} v V_{S+} @ $I_{LOAD} = 4A$

INTENTIONALLY BLANK

INTENTIONALLY BLANK

IMPORTANT NOTICE

DIODES INCORPORATED MAKES NO WARRANTY OF ANY KIND, EXPRESS OR IMPLIED, WITH REGARD TO THIS DOCUMENT, INCLUDING, BUT NOT LIMITED TO, THE IMPLIED WARRANTIES OF MERCHANTABILITY AND FITNESS FOR A PARTICULAR PURPOSE (AND THEIR EQUIVALENTS UNDER THE LAWS OF ANY JURISDICTION).

Diodes Incorporated and its subsidiaries reserve the right to make modifications, enhancements, improvements, corrections or other changes without further notice to this document and any product described herein. Diodes Incorporated does not assume any liability arising out of the application or use of this document or any product described herein; neither does Diodes Incorporated convey any license under its patent or trademark rights, nor the rights of others. Any Customer or user of this document or products described herein in such applications shall assume all risks of such use and will agree to hold Diodes Incorporated and all the companies whose products are represented on Diodes Incorporated website, harmless against all damages.

Diodes Incorporated does not warrant or accept any liability whatsoever in respect of any products purchased through unauthorized sales channels. Should Customers purchase or use Diodes Incorporated products for any unintended or unauthorized application, Customers shall indemnify and hold Diodes Incorporated and its representatives harmless against all claims, damages, expenses, and attorney fees arising out of, directly or indirectly, any claim of personal injury or death associated with such unintended or unauthorized application.

Products described herein may be covered by one or more United States, international or foreign patents pending. Product names and markings noted herein may also be covered by one or more United States, international or foreign trademarks.

LIFE SUPPORT

Diodes Incorporated products are specifically not authorized for use as critical components in life support devices or systems without the express written approval of the Chief Executive Officer of Diodes Incorporated. As used herein:

A. Life support devices or systems are devices or systems which:

1. are intended to implant into the body, or
2. support or sustain life and whose failure to perform when properly used in accordance with instructions for use provided in the labeling can be reasonably expected to result in significant injury to the user.

B. A critical component is any component in a life support device or system whose failure to perform can be reasonably be expected to cause the failure of the life support device or to affect its safety or effectiveness.

Customers represent that they have all necessary expertise in the safety and regulatory ramifications of their life support devices or systems, and acknowledge and agree that they are solely responsible for all legal, regulatory and safety-related requirements concerning their products and any use of Diodes Incorporated products in such safety-critical, life support devices or systems, notwithstanding any devices- or systems-related information or support that may be provided by Diodes Incorporated. Further, Customers must fully indemnify Diodes Incorporated and its representatives against any damages arising out of the use of Diodes Incorporated products in such safety-critical, life support devices or systems.

Copyright © 2009, Diodes Incorporated

www.diodes.com

Sales offices**The Americas**

3050 E. Hillcrest Drive
Westlake Village,
CA 91362-3154
Tel: (+1) 805 446 4800
Fax: (+1) 805 446 4850

Europe

Kustermannpark
Balanstraße 59,
D-81541 München
Germany
Tel: (+49) 894 549 490
Fax: (+49) 894 549 4949

Taiwan

7F, No. 50,
Min Chuan Road
Hsin-Tien
Taipei, Taiwan
Tel: (+886) 289 146 000
Fax: (+886) 289 146 639

Shanghai

Rm. 606, No.1158
Changning Road
Shanghai, China
Tel: (+86) 215 241 4882
Fax (+86) 215 241 4891

Shenzhen

Room A1103-04,
ANLIAN Plaza, #4018
Jintian Road
Futian CBD,
Shenzhen, China
Tel: (+86) 755 882 849 88
Fax: (+86) 755 882 849 99

Korea

6 Floor, Changhwa B/D,
1005-5 Yeongtong-dong,
Yeongtong-gu, Suwon-si,
Gyeonggi-do, Korea 443-813
Tel: (+82) 312 731 884
Fax: (+82) 312 731 885