

DESCRIPTION

The ZXCT1022EV1 evaluation board is intended for the evaluation of the ZXCT1022 device.

The ZXCT1022 is a precision high-side current sense monitor. Using this type of device eliminates the need to disrupt the ground plane when sensing a load current. The ZXCT1022 provides a fixed gain of 100 for applications where minimal sense voltage is required. The very low offset voltage enables a typical accuracy of 3% for sense voltages of only 10mV, giving better tolerances for small sense resistors necessary at higher currents. The wide input voltage range of 20V down to as low as 2.5V makes it suitable for a range of applications.

It requires no additional components thus making it a versatile device with minimal components count.

The evaluation board is delivered with the values shown in Figure 1 below. As can be seen, R_S consists of two resistors (R1 and R2) which are configured in parallel such that either one or both resistors could be connected by completing the solder-bridge link next to each one. R2 (0.1R) is connected by default.

R3 consists of two pads with a hole in each pad and provides means for connecting an external R_S .

With the values shown the board produces an output of 1V/A

The printed circuit board is common to other devices in the ZXCT family and contains redundant component positions which will not be discussed here as they are not relevant.

FEATURES

- High side current sensing
- Supply Range 2.5V to 20V.
- Fixed gain of 100
- 1% typical accuracy
- 5 Pin SOT23-5 package

APPLICATIONS

- Battery Charging
- Power Supplies
- Over Current Monitoring
- Automotive current measurement

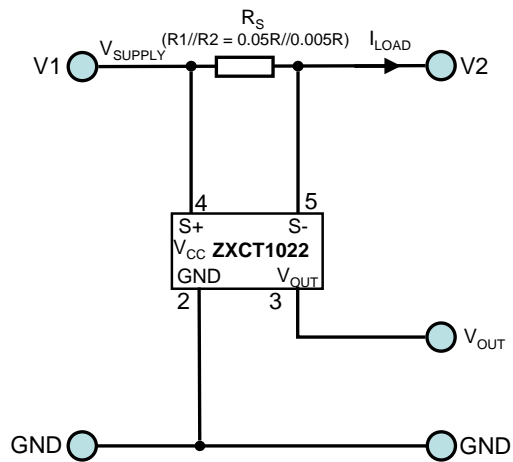

Figure 1 Equivalent circuit diagram for evaluation board ZXCT1022EV1

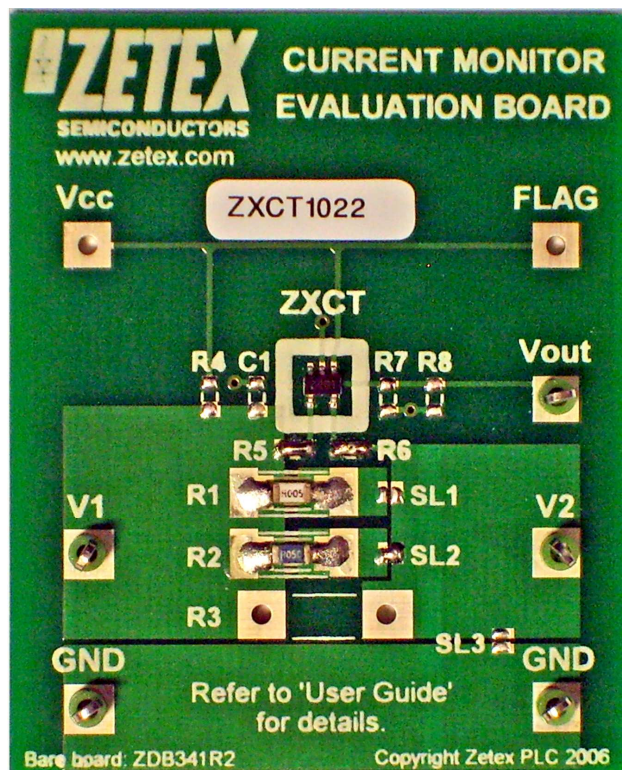

Figure 2 Evaluation board components' layout



ZXCT1022EV1

Evaluation Board

User Guide

Doc: ZXCT1022EV1-UG
Issue: 1.0
Date: 25 March 2008
Page: 3 of 8

ORDERING INFORMATION

ORDER NUMBER
ZXCT1022EV1

Please note evaluation boards are subject to availability and qualified leads.

PAD NAMES AND DEFINITIONS

NAME	DESCRIPTION
V1	Supply Voltage
V2	Connection to Load
VOUT	Output Voltage
FLAG	Not used
GND	0V / Ground
SL1,SL2	Solder Links
V _{CC}	Not used

The target applications are battery chargers, power supply units and other applications where high side current measurement is a requirement.

The input voltage (voltage on V1) range for the ZXCT1022EV1 is from 2.5V to 20V.

ZXCT1022EV1 Summary

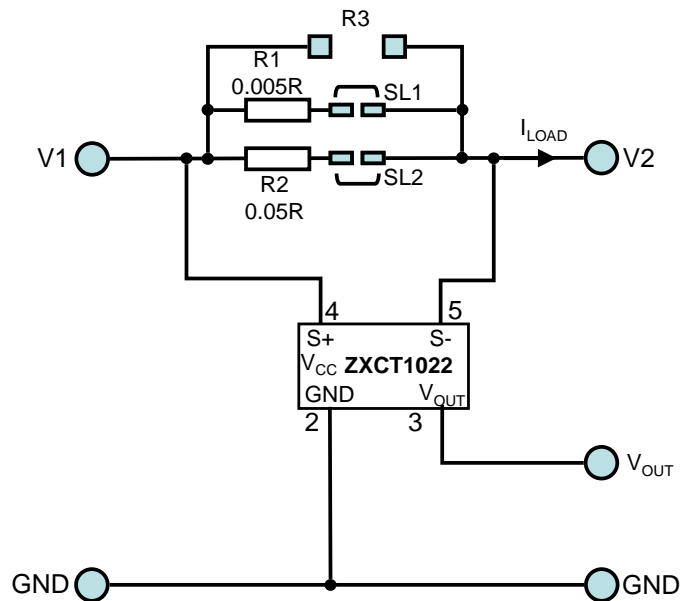

Figure 3 Actual circuit diagram for ZXCT1022EV1

Sense resistor

The board has been designed with two selectable values of sense resistor. The value of the sense resistor can be chosen by using the solder links SL1 and SL2.

The board is also tracked for a user defined through hole resistor (R3).

The 5mΩ resistor (R1) is selected by shorting SL1 and opening SL2. This results in an output of 0.5 V/A.

The 50mΩ resistor (R2) is selected by shorting SL2 and opening SL1, resulting in an output of 5V/A.

If both links are shorted the effective resistance is 4.54mΩ giving an output of 454 mV/A.

If both links are open, the optional leaded resistor R3 can be exclusively used as the sense resistor. The maximum power dissipation rating of the resistor must be appropriate to the load current level.

For further information on choosing a value of sense resistor please refer to the ZXCT1022 datasheet.

Configuration table for ZXCT1022EV1

LOAD CURRENT (A)	R_{SENSE} (mΩ)	V_{OUT} (V)	SOLDER LINK CONFIGURATION
1.0	5	0.5	Short SL1
1.0	50	5	Short SL2
1.0	4.54	0.454	Short SL1 & SL2

Configuration for different LOAD currents.

The board can be configured for different load currents by changing the SMD resistors or fitting a suitable wire ended resistor and opening both solder links. It is important to ensure an appropriate value of R_S is selected to obtain the desired accuracy for a given output current.

The value of V_{OUT} is the voltage dropped across the sensing resistor multiplied by a hundred.

Choosing a larger value for R_S gives a higher output voltage for a given current resulting in better resolution but at the expense of increased voltage drop and higher dissipation in R_S .

The ZXCT1022 is optimized for values of V_{SENSE} between 10mV and 100mV.

Accuracy

The ZXCT1022 has a typical 3% accuracy for a V_{SENSE} of between 10mV and 100mV. The accuracy of the output voltage will be influenced by the tolerance of the external sense used. The ZXCT1022EV1 utilizes 1% sense resistors.

COMPONENTS LIST

Ref	Value	Package	Part Number	Manufacturer	Notes
R1	5m Ω	1206	LR1206-R005FI	Welwyn	SMD Sense Resistor 1%
R2	50m Ω	1206	LR1206-R050FI	Welwyn	SMD Sense Resistor 1%
R5,R6	0R	Link			
ZXCT		SOT23-5	ZXCT1022E5	ZETEX	

SET-UP AND TEST

The board is preset to give an output Voltage of 5V for a load current of 1A - SL2 is shorted to connect in the 50m Ω (R2) sense resistor. To change the board to give an output Voltage of 0.5V for a current of 1.0A, de-solder SL2 and short SL1. This connects the 5m Ω (R1) sense resistor.

Required Equipment

1. 1 x 10R 5W resistor (load).
2. 1 x adjustable bench PSU's.
3. 2 x DVM's (one for voltage measurement and one for current measurement)

500mA load test

1. Ensure SL2 is shorted.
2. Connect the bench power supply, PSU1, between the V1 and GND terminals.
3. Connect a resistor in series with an ammeter set to 1A or 2A range between the V2 and GND terminals - 10R 5W suggested. If using a different value, make sure its power rating is $P \geq 2(I^2 \cdot R)$. Make sure PSU1 is set to zero volts to start with.
4. Switch on PSU1 and adjust until the ammeter reads 500 mA \pm 2 mA,
5. Measure V_{OUT} with a DVM. The output voltage should read 2.5V \pm 0.1 V.

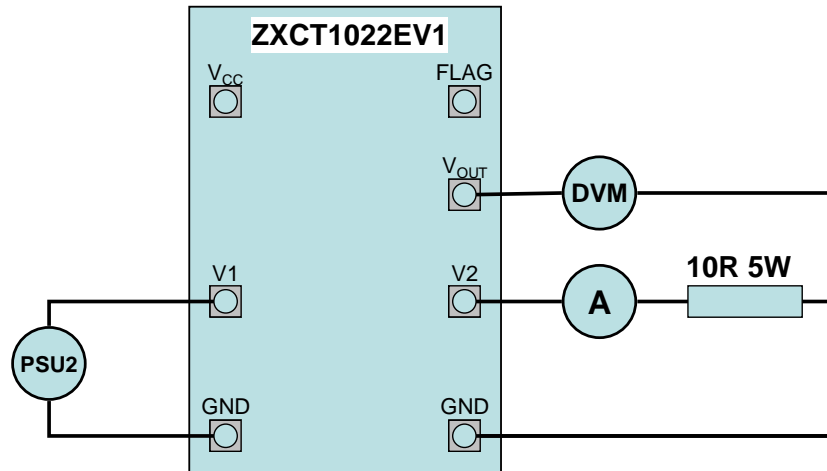
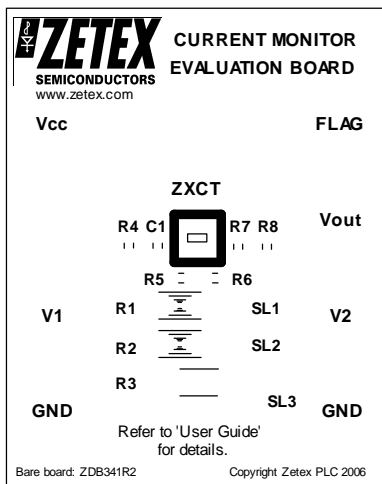
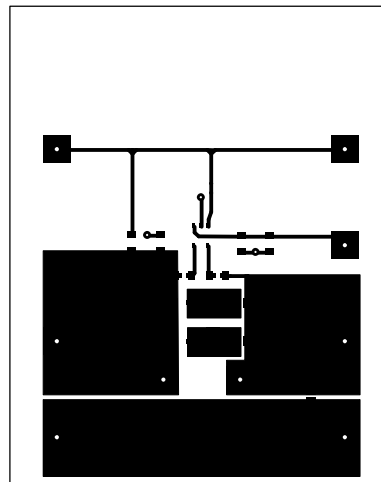

Figure 4 Test diagram for ZXCT1022EV1

EVALUATION BOARD



Top Silk



Top Copper



ZXCT1022EV1 Evaluation Board User Guide

Doc: ZXCT1022EV1-UG
Issue: 1.0
Date: 25 March 2008
Page: 8 of 8

Definitions

Product change

Zetex Semiconductors reserves the right to alter, without notice, specifications, design, price or conditions of supply of any product or service. Customers are solely responsible for obtaining the latest relevant information before placing orders.

Applications disclaimer

The circuits in this design/application note are offered as design ideas. It is the responsibility of the user to ensure that the circuit is fit for the user's application and meets with the user's requirements. No representation or warranty is given and no liability whatsoever is assumed by Zetex with respect to the accuracy or use of such information, or infringement of patents or other intellectual property rights arising from such use or otherwise. Zetex does not assume any legal responsibility or will not be held legally liable (whether in contract, tort (including negligence), breach of statutory duty, restriction or otherwise) for any damages, loss of profit, business, contract, opportunity or consequential loss in the use of these circuit applications, under any circumstances.

Life support

Zetex products are specifically not authorized for use as critical components in life support devices or systems without the express written approval of the Chief Executive Officer of Zetex Semiconductors plc. As used herein:

A. Life support devices or systems are devices or systems which:

1. are intended to implant into the body

or

2. support or sustain life and whose failure to perform when properly used in accordance with instructions for use provided in the labelling can be reasonably expected to result in significant injury to the user.

B. A critical component is any component in a life support device or system whose failure to perform can be reasonably expected to cause the failure of the life support device or to affect its safety or effectiveness.

Reproduction

The product specifications contained in this publication are issued to provide outline information only which (unless agreed by the company in writing) may not be used, applied or reproduced for any purpose or form part of any order or contract or be regarded as a representation relating to the products or services concerned.

Terms and Conditions

All products are sold subjects to Zetex' terms and conditions of sale, and this disclaimer (save in the event of a conflict between the two when the terms of the contract shall prevail) according to region, supplied at the time of order acknowledgement.

For the latest information on technology, delivery terms and conditions and prices, please contact your nearest Zetex sales office.

Quality of product

Zetex is an ISO 9001 and TS16949 certified semiconductor manufacturer.

To ensure quality of service and products we strongly advise the purchase of parts directly from Zetex Semiconductors or one of our regionally authorized distributors. For a complete listing of authorized distributors please visit: www.zetex.com/salesnetwork

Zetex Semiconductors does not warrant or accept any liability whatsoever in respect of any parts purchased through unauthorized sales channels.

ESD (Electrostatic discharge)

Semiconductor devices are susceptible to damage by ESD. Suitable precautions should be taken when handling and transporting devices. The possible damage to devices depends on the circumstances of the handling and transporting, and the nature of the device. The extent of damage can vary from immediate functional or parametric malfunction to degradation of function or performance in use over time. Devices suspected of being affected should be replaced.

Green compliance

Zetex Semiconductors is committed to environmental excellence in all aspects of its operations which includes meeting or exceeding regulatory requirements with respect to the use of hazardous substances. Numerous successful programs have been implemented to reduce the use of hazardous substances and/or emissions.

All Zetex components are compliant with the RoHS directive, and through this it is supporting its customers in their compliance with WEEE and ELV directives.

Product status key:

"Preview"	Future device intended for production at some point. Samples may be available
"Active"	Product status recommended for new designs
"Last time buy (LTB)"	Device will be discontinued and last time buy period and delivery is in effect
"Not recommended for new designs"	Device is still in production to support existing designs and production
"Obsolete"	Production has been discontinued

Datasheet status key:

"Draft version"	This term denotes a very early datasheet version and contains highly provisional information, which may change in any manner without notice.
"Provisional version"	This term denotes a pre-release datasheet. It provides a clear indication of anticipated performance. However, changes to the test conditions and specifications may occur, at any time and without notice.
"Issue"	This term denotes an issued datasheet containing finalized specifications. However, changes to specifications may occur, at any time and without notice.

Europe	Americas	Asia Pacific	Corporate Headquarters
Zetex GmbH Kustermann-park Balanstraße 59 D-81541 München Germany Telefon: (49) 89 45 49 49 0 Fax: (49) 89 45 49 49 49 europe.sales@zetex.com	Zetex Inc 700 Veterans Memorial Highway Hauppauge, NY 11788 USA Telephone: (1) 631 360 2222 Fax: (1) 631 360 8222 usa.sales@zetex.com	Zetex (Asia Ltd) 3701-04 Metroplaza Tower 1 Hing Fong Road, Kwai Fong Hong Kong Telephone: (852) 26100 611 Fax: (852) 24250 494 asia.sales@zetex.com	Zetex Semiconductors plc Zetex Technology Park, Chadderton Oldham, OL9 9LL United Kingdom Telephone (44) 161 622 4444 Fax: (44) 161 622 4446 hq@zetex.com

© 2006 Published by Zetex Semiconductors plc.