

3. PAM8803DS Description

PAM8803 EVB is designed for PAM8803 evaluation, targeted to be used in providing a simple and convenient evaluation environment for the PAM8803. Requires parts, potentiometer for standard RCA jacks for audio inputs, pin jacks for power supply and signal outputs, low-pass RC output filter for each channel, etc. on the board make it easy to be evaluated.

4. EVB Graph Package SSOP24

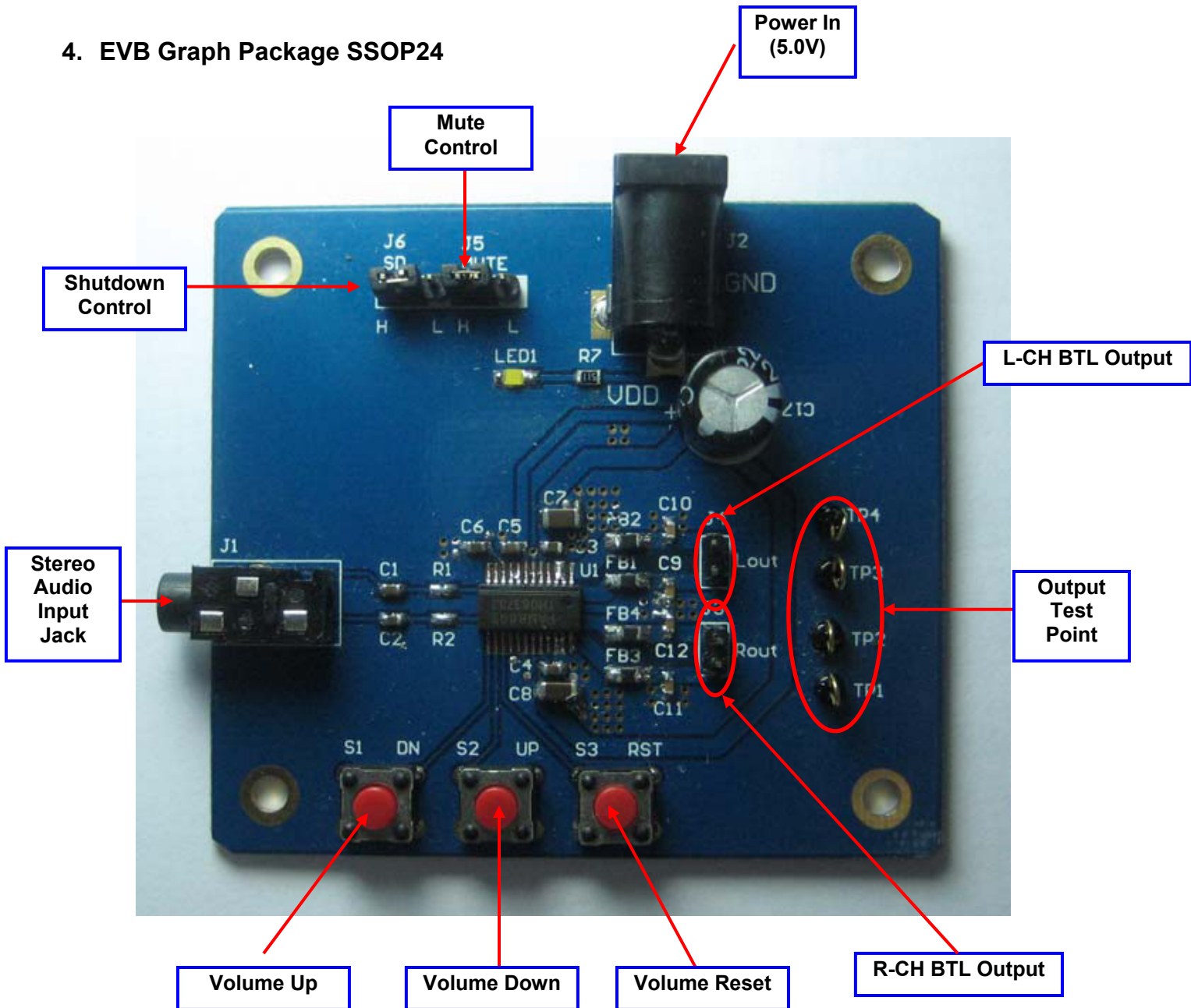

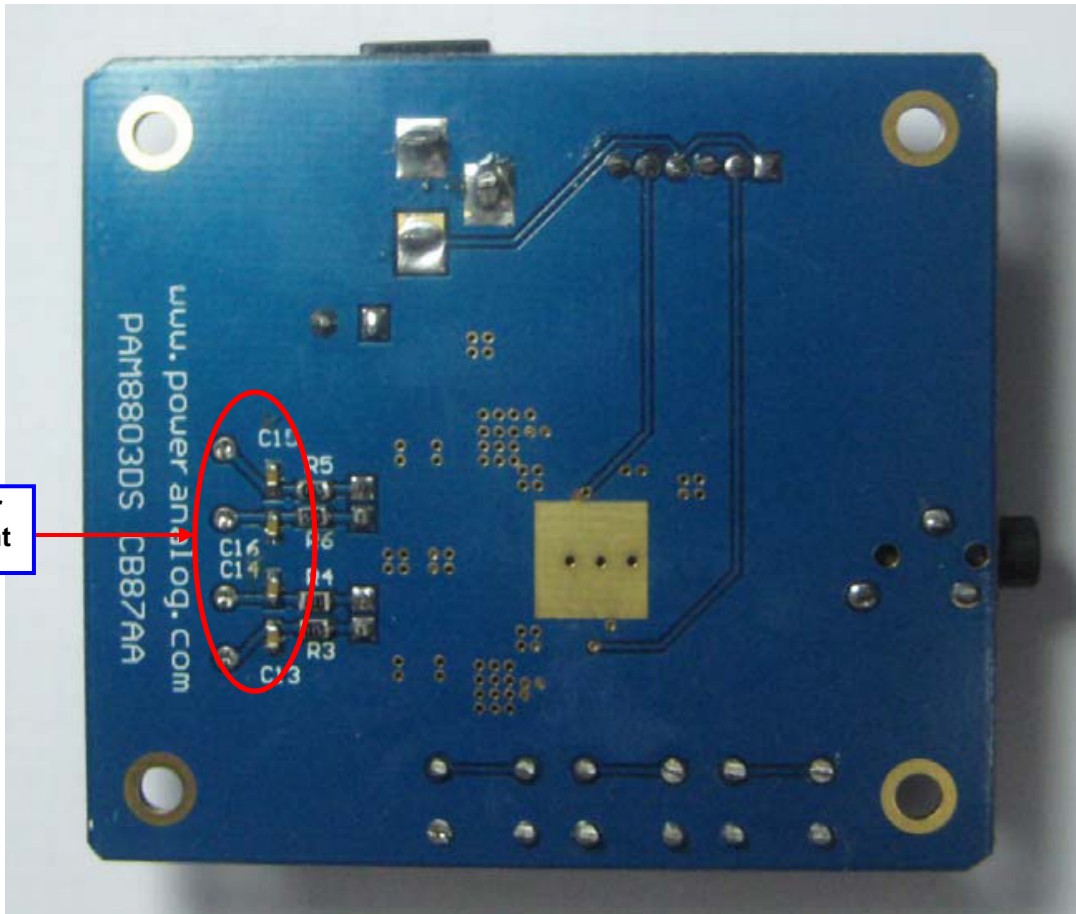

**RC Filter for
Measurement**

5. EVB BOM List

Capacitors	Qty	Value	Description	Rating	Package	Purpose
C1, C2	2	0.47 μ F	Ceramic X5R/X7R	6.3V	0603	Input Coupling
C3, C4, C5	4	1.0 μ F	Ceramic X5R/X7R	6.3V	0603	VDD Bypass
C6	1	1.0 μ F	Ceramic X5R/X7R	6.3V	0603	VREF Bypass
C7, C8	2	10.0 μ F	Ceramic X5R/X7R	6.3V	0805	PVDD Main Bypass
C17	1	470 μ F	Electrolytic	10V		Power in Bypass
Resistors	Qty	Value	Description	Rating	Package	Purpose
R1, R2	2	1k Ω	1% Tolerance		0603	Input Resistor, Option
EMI Components	Qty	Value	Description	Rating	Package	Purpose
FB1, FB2, FB3, FB4	4	120 Ω	PBY201209T-600Y-N		0805	EMI Component
C9, C10, C11, C12	4	220pF	Ceramic X5R/X7R	25V	0603	EMI Component
Test Components	Qty	Value	Description	Rating	Package	Purpose
C13, C14, C15, C16	4	10nF	Ceramic X5R/X7R	6.3V	0603	Test Component
R3, R4, R5, R6	4	500 Ω	RES, SMD J, RT		0603	Test Component
Indicate Section	Qty	Value	Description	Rating	Package	Purpose
R7	1	300 Ω			0805	
LED1	1					Power On Indicate
Jack	Qty	Value	Description	Rating	Package	Purpose
J1	1		Audio Input			
J2	1		Power Supply			
J3	1		L-CH-BTL Output			
J4	1		R-CH-BTL Output			
J5	1		Mute			
J6	1		Shutdown			
Key	Qty	Value	Description	Rating	Package	Purpose
S1						Volume Down Control
S2						Volume Up Control
S3						Volume Reset Control

6. PCB Layout

Top Layer

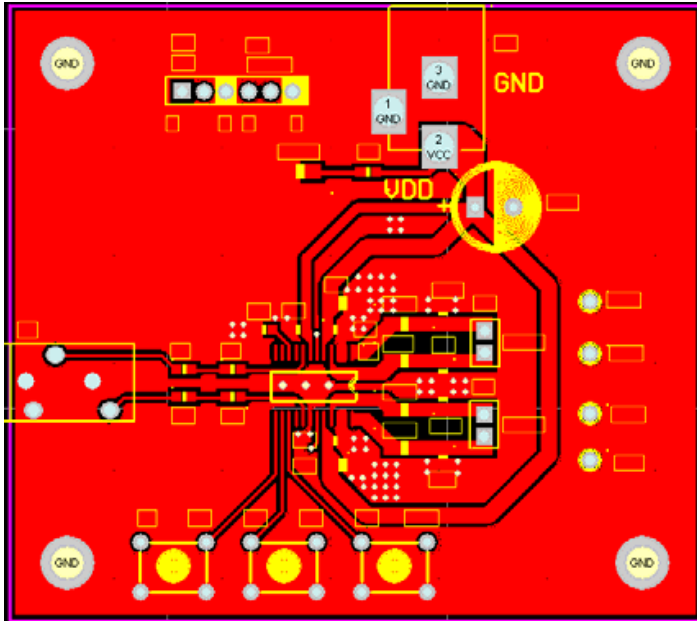

Bottom Layer

