

2. Key Features

- ◆ 3W Output at 10% THD with a 4Ω load and 5V Power Supply
- ◆ 2.4W Output at 1% THD with a 4Ω Load and 5V Power Supply
- ◆ Filterless, Low Quiescent Current and Low EMI
- ◆ Low THD+N
- ◆ 32-step Digital Volume Control from -80dB(mute) to 24dB
- ◆ Superior Low Noise: 60uV
- ◆ Minimize Pop/Clip Noise
- ◆ High Efficiency up to 90%
- ◆ Auto Recovery Short Circuit Protection
- ◆ Thermal Shutdown
- ◆ Pb-Free Package

3. EV Board Schematic

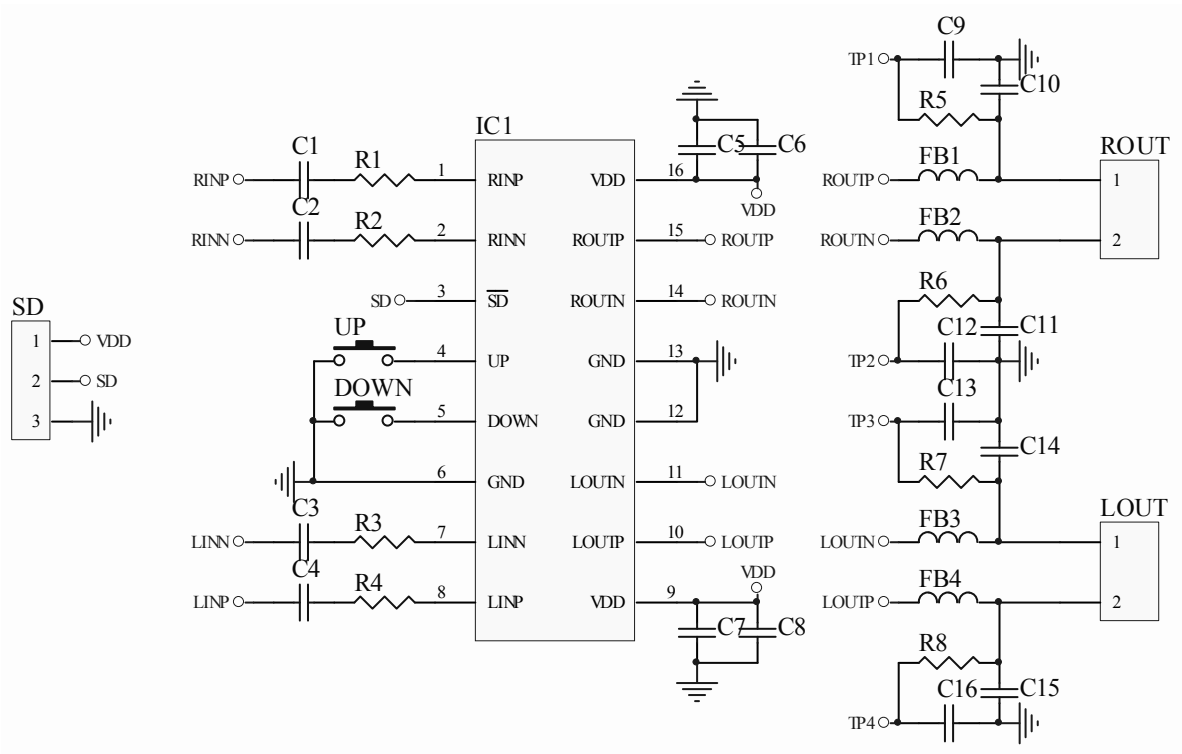

This application note contains new product information. Diodes, Inc. reserves the right to modify the product specification without notice. No liability is assumed as a result of the use of this product. No rights under any patent accompany the sale of the product.

4. EV-Board PAM8407 EB37AA Description

PAM8407 EB37AA is designed for evaluated PAM8407. The PAM8407 is a 3W, class-D audio amplifier. Advanced 32-step Digital volume control minimizes external components and allows speaker volume control. The board is targeted to be used in providing a simple and convenient evaluation environment for the PAM8407.

5. EV Board View and Jack Description

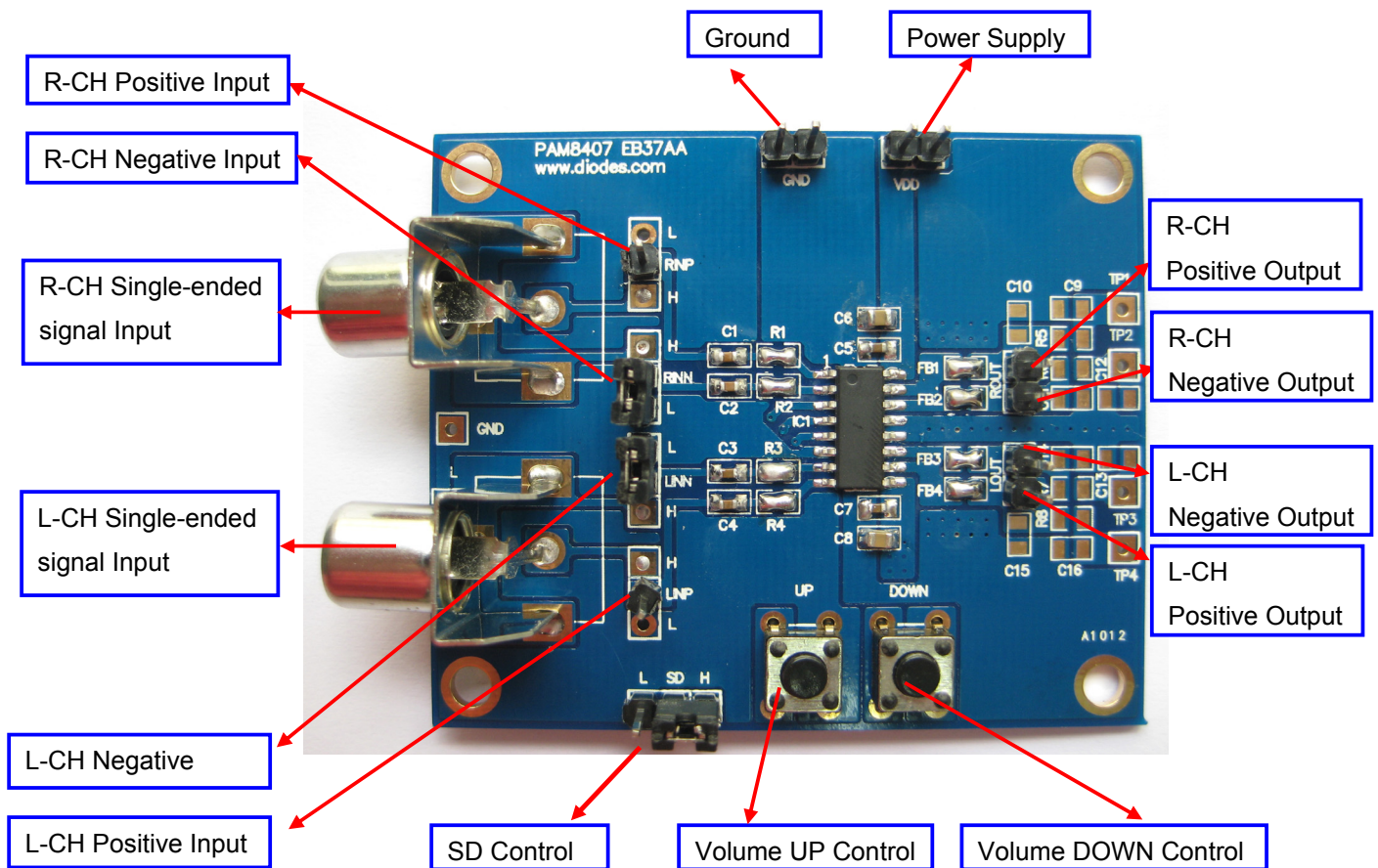

This application note contains new product information. Diodes, Inc. reserves the right to modify the product specification without notice. No liability is assumed as a result of the use of this product. No rights under any patent accompany the sale of the product.

6. EV board operational sequence:

- a. Connect SD to a high for normal operation.
- b. To use the PAM8407 with a differential source, connect the positive lead of the audio source to the INP input and the negative lead of the audio source to the INN input. To use the PAM8407 with a single-ended source, the INN input should be ac-grounded.
- c. Connect the loading (speaker or power resistor) to the output jack.
- d. Power on: 2.7V to 5.5V DC power supply.

7. EV Board BOM List

Item	Value	Type	Rating	Description	Vender and port
C1,C2, C3,C4	0.1uF	X5R/X7R, Ceramic/0603	25V	Input coupling CAP	TAIYO YUDEN UMK212B7104KG-T
C5, C7	1uF	X5R/X7R, Ceramic/0603	25V	VDD coupling CAP,	TAIYO YUDEN TMK107B7105KA-T
C6, C8	10uF	X5R/X7R, Ceramic/0805	16V	VDD main coupling CAP,	TAIYO YUDEN EMK212ABJ106KD-T
R1,R2, R3,R4	0ohm	0603	1%	Input Resistor	
IC1	PM8407	SOP-16L			

This application note contains new product information. Diodes, Inc. reserves the right to modify the product specification without notice. No liability is assumed as a result of the use of this product. No rights under any patent accompany the sale of the product.

8. PCB Layout Example

Top layer

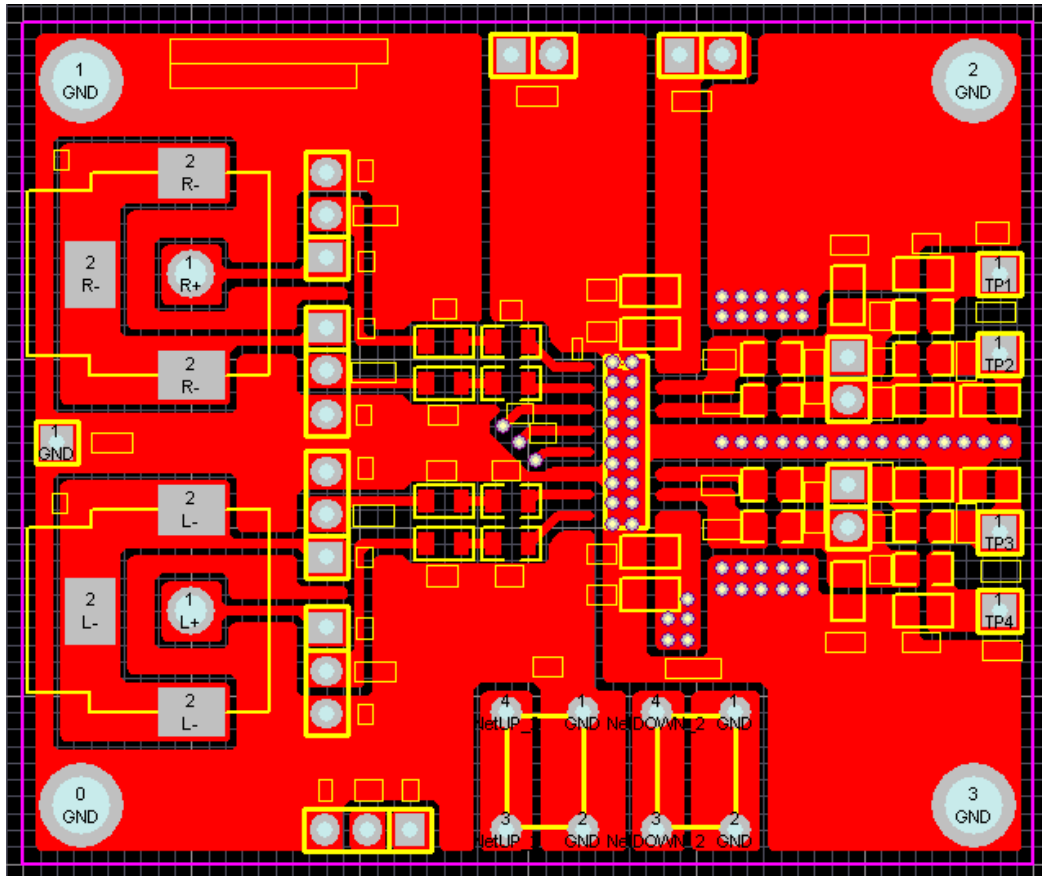

This application note contains new product information. Diodes, Inc. reserves the right to modify the product specification without notice. No liability is assumed as a result of the use of this product. No rights under any patent accompany the sale of the product.

Bottom layer

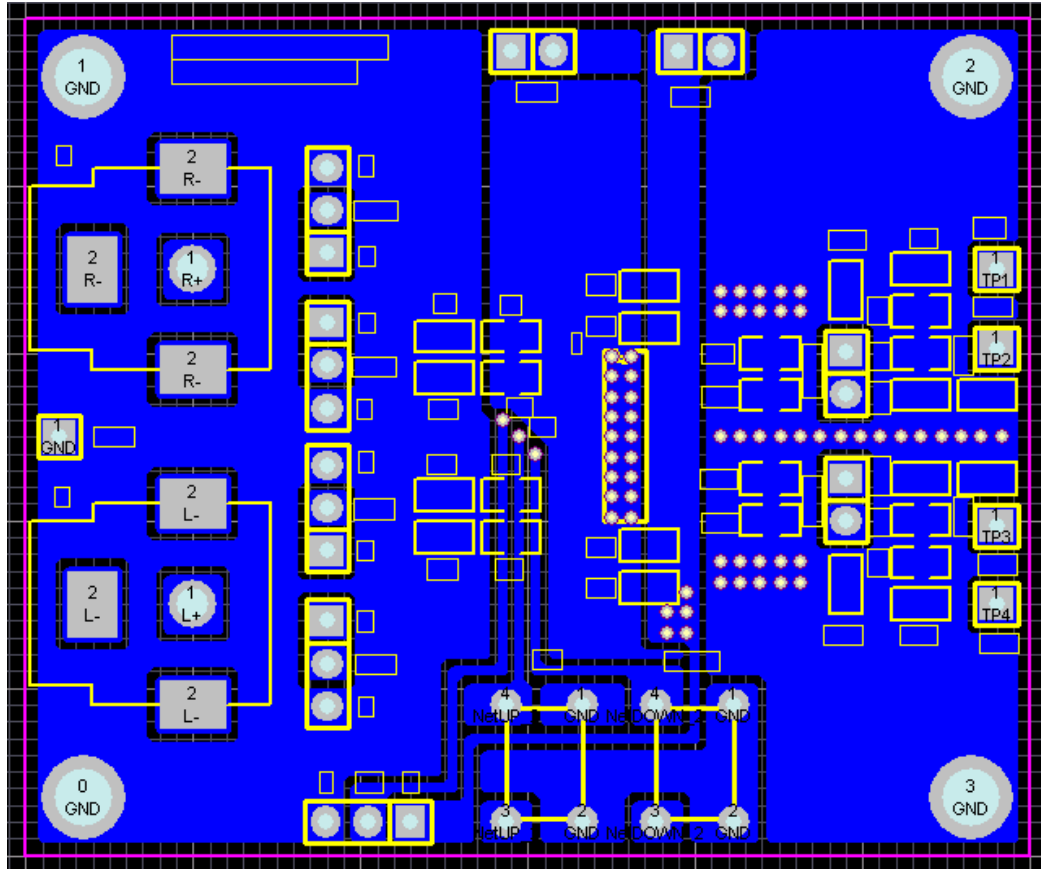

This application note contains new product information. Diodes, Inc. reserves the right to modify the product specification without notice. No liability is assumed as a result of the use of this product. No rights under any patent accompany the sale of the product.