

2. PAM2401 General Description

The PAM2401 is a high efficiency, current mode, fixed frequency, step-up DC/DC converter with true output disconnect and inrush current limiting. The device includes one 0.10 Ω N-channel MOSFET switch and one 0.15 Ω P-channel synchronous rectifier. This product has the ability to simply program the output voltage from 2.5V to 5.0V. The switching frequency is 1.0MHz programmable current limit set by an external resistor from 1.0A to 3.0A with internal soft-start. When loading became light, the converter will automatically enter into PSM to improve the efficiency.

Quiescent current is only 150uA during Pulse Skip Mode operation, maximizing battery life in portable applications. Other features include: <1uA shutdown, anti-ringing control, Hiccup mode at short protection, over voltage protection and over temperature protection.

The PAM2401 is available in MSOP-8 and U-DFN3030-12 packages

3. Key Features

- Up to 95% Efficiency
- True Output Disconnect
- Inrush Current Limiting When Power On
- Output Current up to 1000mA at $V_{in}=3V$ and $V_{out}=5.0V$
- Fixed Frequency Operation Up to 1MHz
- 0.9V to 4.75V Input Range
- 2.5V to 5.0V Adjustable Output Voltage
- Guaranteed 1.0V Start-Up
- Programmable Current Limit
- Internal Soft-Start
- Internal Compensation
- Pulse Skipping Mode at Light Load Operation
- Hiccup Mode Short Protection
- Over Voltage Protection
- Over Temperature Protection
- <1uA Shutdown Current
- Power Good Indicator
- MSOP-8 and U-DFN3030-12 packages

DO NOT DISTRIBUTE OR REPRODUCE WITHOUT PERMISSION FROM P.A.M

4. EV Board Schematic

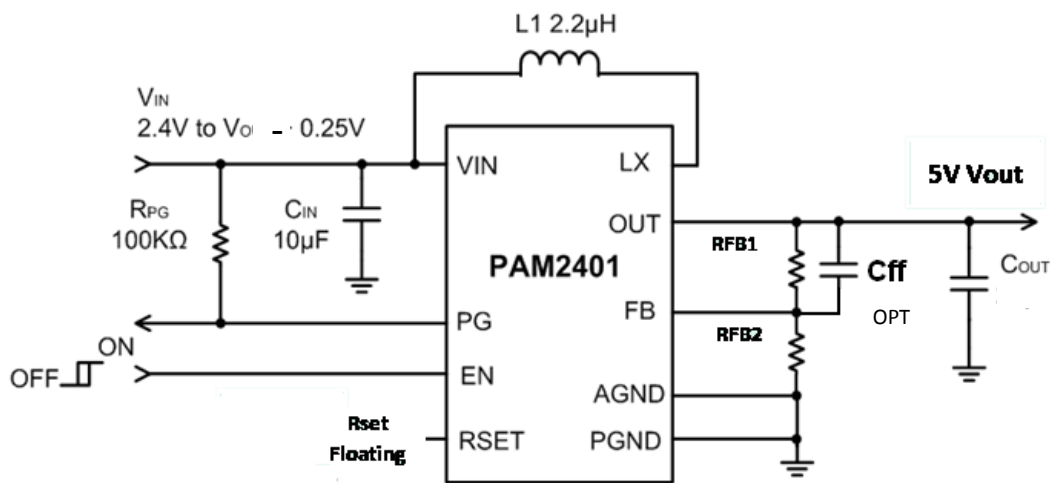

5. EVB PAM2401 Description

PAM2401 EB33AA and EB33AB are both suitable evaluation board for the PAM2401, a DC/DC converter. The board is targeted to be used in providing a simple and convenient evaluation environment for the PAM2401. Requires parts, power supply connectors etc. on the board, which makes it easy to be evaluated.

DO NOT DISTRIBUTE OR REPRODUCE WITHOUT PERMISSION FROM P.A.M

Power Analog Microelectronics, Inc.

Rev. V2.0
April, 2014

6. EV Board View

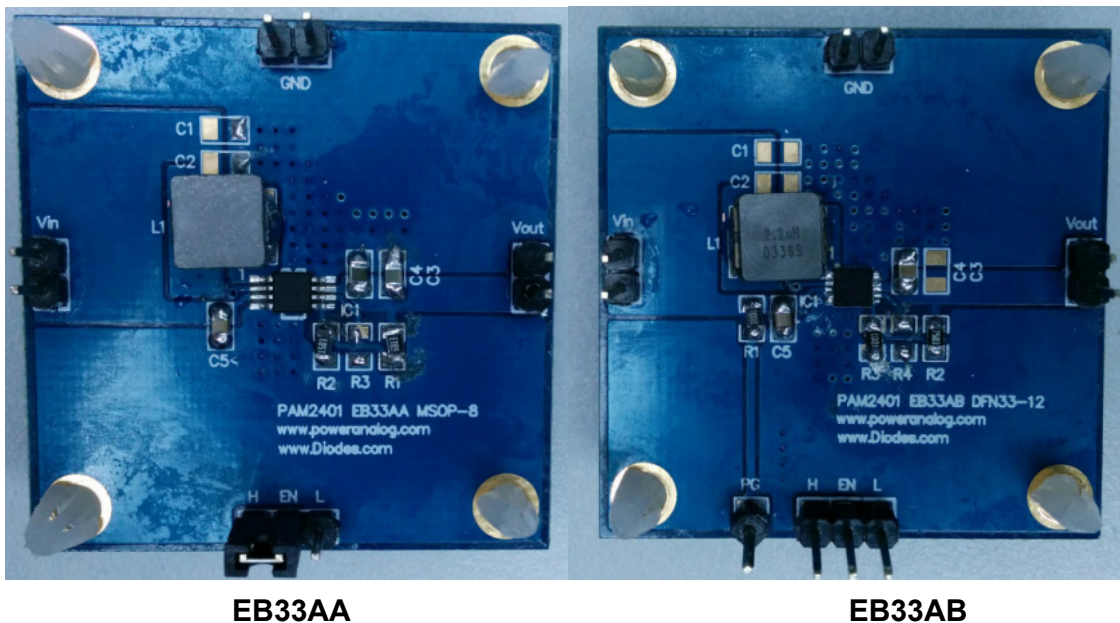

7. Resistor select for output voltage setting

$$V_{out} = (1 + R1/R2) \times V_{ref} \quad (\text{For EB33AA}) \quad (V_{ref}=0.6V)$$

$$V_{out} = (1 + R2/R3) \times V_{ref} \quad (\text{For EB33AB})$$

Vo	R1(R2)	R2(R3)	L1
3.3V	680k	150k	1.5uH
3.6V	750k	150k	1.5uH
4.2V	620k	100k	1.5uH
5V	825k	110k	2.2uH

DO NOT DISTRIBUTE OR REPRODUCE WITHOUT PERMISSION FROM P.A.M

8. External Components Selection

Input & output Capacitors ($C_{1/2/5}$, $C_{3/4}$)

- (1) For lower output ripple, low ESR is required.
- (2) Low leakage current needed, X5R/X7R ceramic recommend, multiple capacitor parallel connection.
- (3) For output lower than 4.2V application, the minimum value of output capacitor should more than 32uF at least.

Output Voltage programmer resistors ($R_{1/2}$, $R_{2/3}$)

- (1) For programmer output voltage
- (2) For accurate output voltage, 1% tolerance is required.

Inductor (L1)

- (1) Low DCR for good efficiency
- (2) Inductance saturate current must higher than the output current

Current Limit Set resistor ($R_{3/4}$)

- (1) Rset floating or Rset >200K, Ilimit=3A
- (2) Rset=100K, Ilimit=1.5A
- (3) Rset=66K, Ilimit=1A

9. Evaluation board BOM list for EB33AA:

Item	Value	Type	Rating	Description	Description
C1,C2,C5	10uF	X5R/X7R, Ceramic/0805	10V	Input coupling CAP	TAIYO YUDEN EMK212ABJ106KD-T
C3,C4	22uF	X5R/X7R, Ceramic/0805	10V	Output coupling CAP	TAIYO YUDEN EMK212ABJ106KD-T
L1	2.2uH		>3A	Inductor	CDMC6D28NP-2R2M
R1	825K	0805	1%	Voltage set RES*	
R2	110K	0805	1%		
R3	Floating			Current Limit Res	Ilimit=3A
IC1		PAM2401	MSOP-8		
PCB		PAM2401 EB33AA			

*Note: The present value of R1/R2 are based on Vout=5V

DO NOT DISTRIBUTE OR REPRODUCE WITHOUT PERMISSION FROM P.A.M

10. Evaluation board BOM list for EB33AB:

Item	Value	Type	Rating	Description	Description
C1,C2,C5	10uF	X5R/X7R, Ceramic/0805	10V	Input coupling CAP	TAIYO YUDEN EMK212ABJ106KD-T
C3,C4	22uF	X5R/X7R, Ceramic/0805	10V	Output coupling CAP	TAIYO YUDEN EMK212ABJ106KD-T
L1	2.2uH		>3A	Inductor	CDMC6D28NP-2R2M
R1	0 Ω	X5R/X7R, Ceramic/0805			
R2	825K	0805	1%	Voltage set RES*	
R3	110K	0805	1%		
R4	Floating			Current Limit Res	Ilimit=3A
IC1		PAM2401	DFN3030-12		
PCB		PAM2401 EB33AB			

*Note: The present value of R1/R2 are based on Vout=5V