

Quick Start Guide:



Figure 1: DDB106R1 Demo Board

Pin	Description
B1	Voltage Input Banana Plug Socket
B3	Voltage Output Banana Plug Socket
B2, B4	GROUND 0V Banana Plug Socket
Vin, Vout, GND1, GND2	Power rail test points
CP	Charge pump test point
J1	Enable pin selection header
EN	Enable pin test point
GATE	MOSFET gate test point

Table 1: DDB106R1 Pin Legend

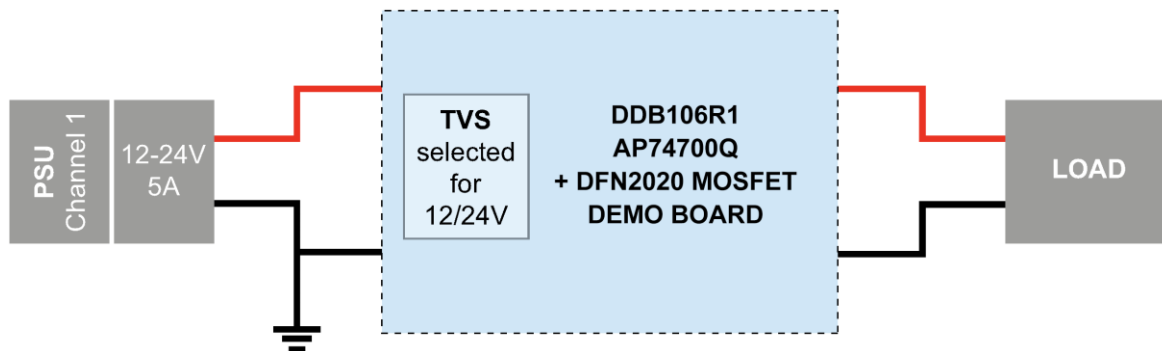

Figure 2: DDB106R1 Test Setup

1. Ensure correct TVS device is used for the testing.
2. Set channel 1 of PSU to 12V or 24V, depending on the TVS device selected, and current limit to 5A.
3. Connect B3 and B4 to a load using banana plugs.
4. Set the jumper to Enabled on the J1 header.
5. Connect B1 to channel 1 of the PSU.
6. Connect B2 to the ground of the PSU.
7. Attach oscilloscope probe to Vin, Vout, and Gate test points, and a current probe between Vout and the load.

Description:

The DDB106R1 Demo Board showcases the [AP74700Q](#), which is an automotive-compliant ideal diode MOSFET controller. When used with an appropriate external N-channel power MOSFET, it provides a low-loss 20mV forward voltage drop rectification in unidirectional power paths and reverse voltage protection. It supports a wide input operation range from 3.2V to 65V, allowing control of many popular DC rail voltages such as 12V, 24V, or higher automotive battery systems. The 3.2V input voltage support is suitable for severe cold crank systems. The AP74700Q can withstand and protect loads from reverse voltages down to -65V. Its internal gate driver quickly turns off the MOSFET during a reverse current event and ensures there is no DC reverse current flow. The fast reverse current blocking response makes it suitable for systems with output voltage holdup requirements during ISO7637-2 pulse testing, as well as power failure and input micro-short conditions. The high 65V voltage rating of the AP74700Q simplifies system designs for automotive ISO7637-2 protection.

The DDB106R1 Demo Board is designed to allow testing of the AP74700Q with a 2x2mm MOSFET in the U-DFN2020-6 package, which provides a compact layout, as seen in Figure 3. Due to the pinout of the U-DFN2020-6 package, the gate pin of the AP74700Q must be routed through vias to the other side of the MOSFET to reach its gate pin.

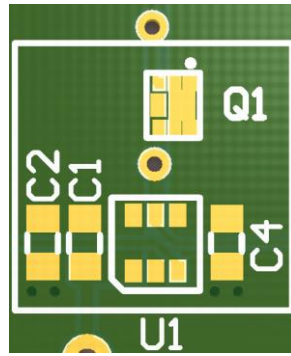

Figure 3: Q1 MOSFET footprint and connection to AP74700Q

MOSFET Selection Table

Based on the design requirements, preferred MOSFET ratings are:

- 60V $V_{DS(MAX)}$ and $\pm 20V$ $V_{GS(MAX)}$
- $R_{DS(ON)} @ I_{Load(Nominal)}: (20mV / I_{Load(Nominal)}) \leq R_{DS(ON)}$
- MOSFET gate threshold voltage V_{TH} : 2V maximum

According to the criteria mentioned above, the following table presents MOSFETs recommended for use with the AP74700Q, depending on the load current:

Part Number	V_{DS} (V)	$R_{DS(ON)} @ V_{GS}=10V$ (m Ω)	$I_{Load(Nominal)}$ (A)*	Package
DMT3020LFDFQ	30	17	1.175 to 6	U-DFN2020-6 (Type F)
DMN3016LFDFQ		12	1.66 to 7	U-DFN2020-6 (Type F)
DMT3006LFDFQ		7	2.85 to 10	U-DFN2020-6 (Type F)
DMN4020LFDEQ	40	21	0.95 to 6	U-DFN2020-6 (Type E)
DMTH4008LFDFWQ**		11.5	1.73 to 9	U-DFN2020-6 (SWP) (Type F)
DMTH6016LFDFWQ	60	18	1.1 to 7	U-DFN2020-6 (SWP) (Type F)

Table 2: MOSFET Selection Table

*Note that the MOSFET's load current limit for ambient temperature applications is closer to the higher value, and for high temperature applications it is closer to the lower value.

**The default MOSFET used on this board is the DMTH4008LFDFWQ.

Description (continued):

The thermal image in Figure 4 shows the AP74700Q driving a DMTH4008LDFWQ at 5A load current at an ambient temperature of $T_A=25^\circ\text{C}$.

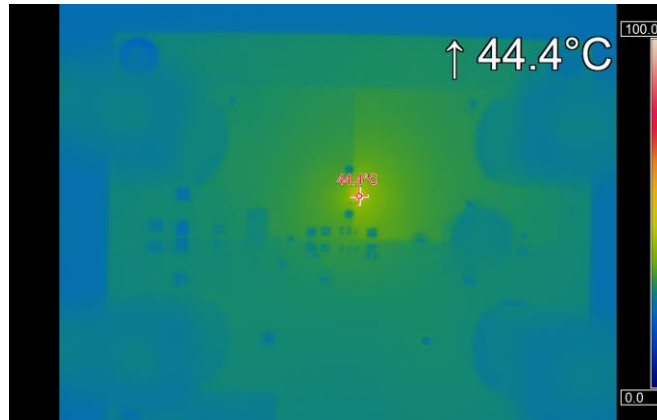

Figure 4: Thermal image of DMTH4008LDFWQ at 5A load current

The DDB106R1 Demo Board comes with 4mm banana plug sockets to make it easier to use. Connections to these points can be made using 4mm banana plugs, or by soldering wires to them. Banana plug sockets B1 and B2 are the inputs of the DDB106R1 Demo Board. Banana plug sockets B3 and B4 are the outputs of the Demo Board. A load must be connected across the outputs of the demo board for it to work optimally.

Table 3 below describes the behavior of the AP74700Q when the jumper on the J1 header is set in different positions.

	J1 jumper position	Behaviour of the AP74700Q
	ENABLED	Normal operation. The AP74700Q regulates the MOSFET's gate voltage to minimize forward conduction losses
	DISABLED	The AP74700Q is in shutdown mode. The forward current flow through the external MOSFET is uninterrupted but is conducted through the MOSFET's body diode.
	Not Connected	Same as DISABLED

Table 3: J1 header jumper position functionality

The board has the option to add TVS protection devices on the input side to protect against voltage spikes that might occur in an automotive environment. The recommended TVS devices to use on the DDB106R1 are either a single SMF bidirectional TVS, which comes in a DO-219AA package with almost half the size of an SMA TVS and the same power rating; or two P6SMA unidirectional TVSs which come in the D-FLAT package with the same size as an SMA but with the power rating of an SMB. The TVS devices are not included as default, and, if used, must be selected according to the voltage range the AP74700Q is tested at.

Board Schematic:

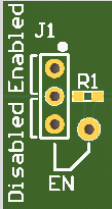
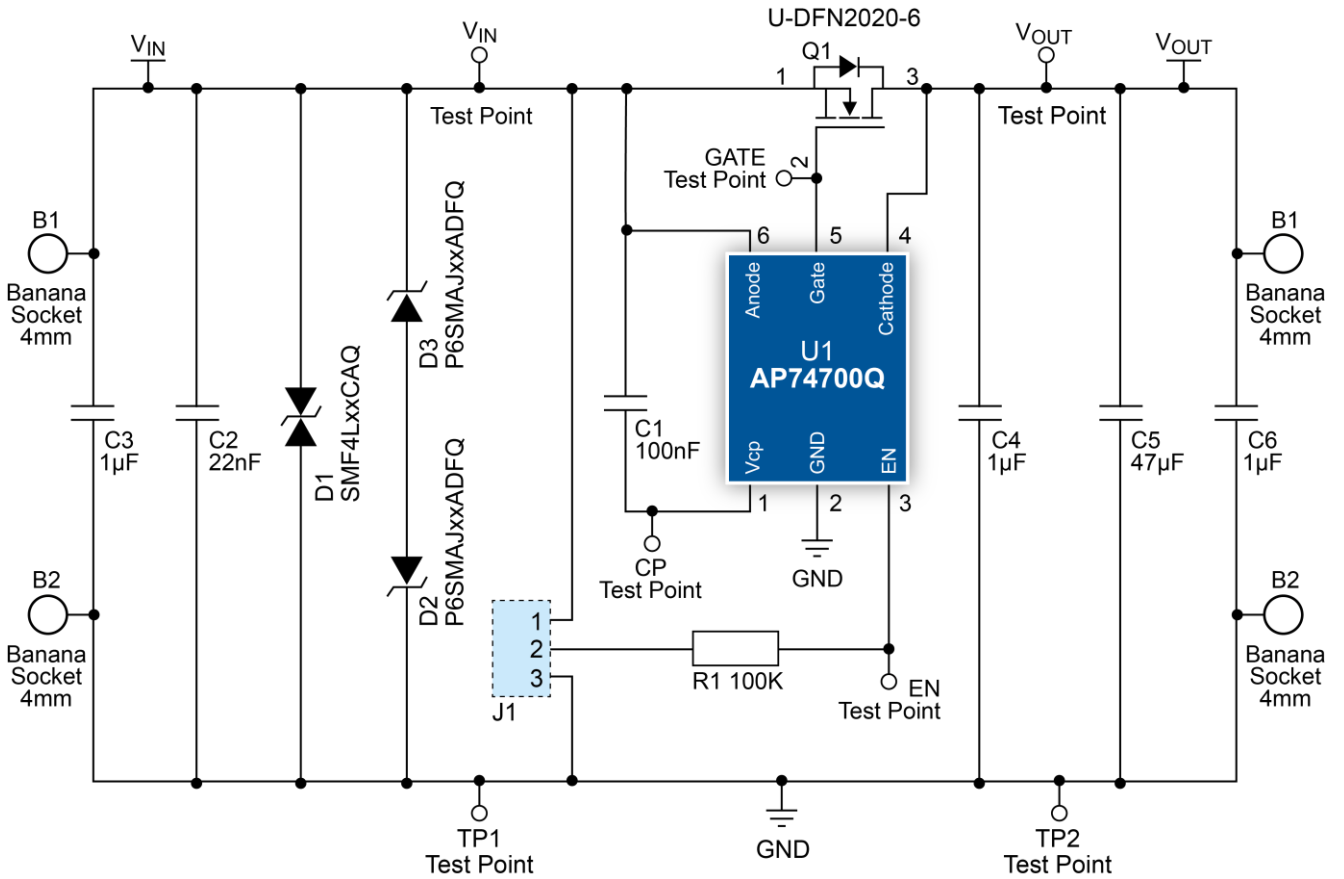

Board Layers (Top View):

Top layer:

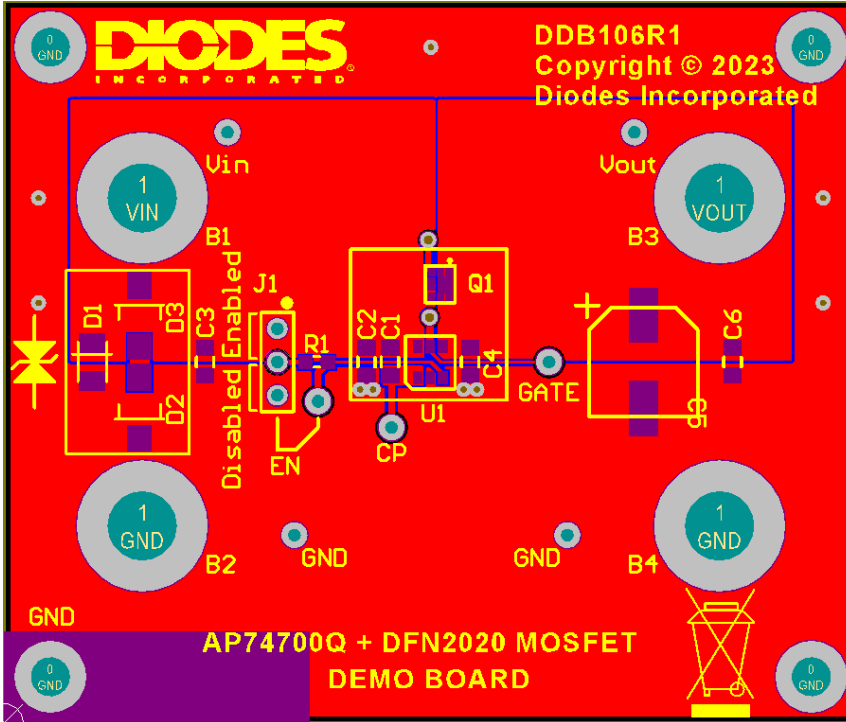

Bottom layer:

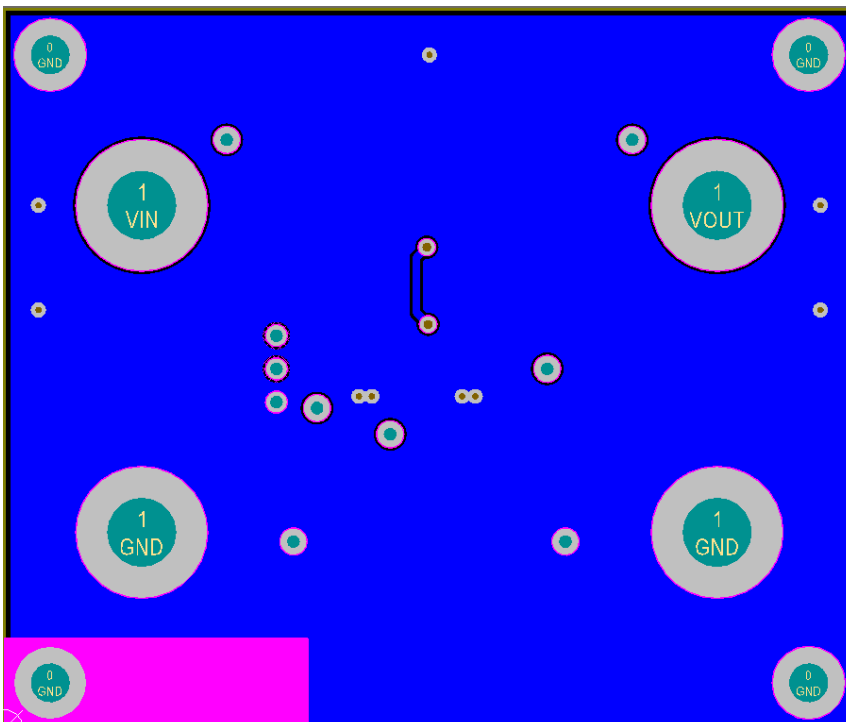

Bill Of Materials:

Qty.	Indents	Description	Footprint
4	B1, B2, B3, B4	Banana Socket 4mm	Banana socket
3	C3, C4, C6	1 μ F X7R 100V Ceramic SMD Capacitor	0805
1	C1	100nF X7R 100V Ceramic SMD Capacitor	0805
1	C2	22nF X7R 100V Ceramic SMD Capacitor	0805
1	C5	47 μ F 80V Electrolytic SMD Capacitor	Case D8
1	R1	100k SMD Resistor	0603
1	J1	3W Header	0.1" 3W
1	U1	AP74700Q	SOT26
1	Q1	MOSFET from selection Table 2 (DMTH4008LDFDQ default)	U-DFN2020-6
1	D1	SMF4LxxCAQ*	DO-219AA
1	D2	P6SMAJxxADFDQ*	D-FLAT
1	D3	P6SMAJxxADFDQ*	D-FLAT

*Note: these components are not fitted on the board and the user should fit the desired TVS device by themselves.

IMPORTANT NOTICE

1. DIODES INCORPORATED (Diodes) AND ITS SUBSIDIARIES MAKE NO WARRANTY OF ANY KIND, EXPRESS OR IMPLIED, WITH REGARDS TO ANY INFORMATION CONTAINED IN THIS DOCUMENT, INCLUDING, BUT NOT LIMITED TO, THE IMPLIED WARRANTIES OF MERCHANTABILITY, FITNESS FOR A PARTICULAR PURPOSE OR NON-INFRINGEMENT OF THIRD PARTY INTELLECTUAL PROPERTY RIGHTS (AND THEIR EQUIVALENTS UNDER THE LAWS OF ANY JURISDICTION).
2. The Information contained herein is for informational purpose only and is provided only to illustrate the operation of Diodes' products described herein and application examples. Diodes does not assume any liability arising out of the application or use of this document or any product described herein. This document is intended for skilled and technically trained engineering customers and users who design with Diodes' products. Diodes' products may be used to facilitate safety-related applications; however, in all instances customers and users are responsible for (a) selecting the appropriate Diodes products for their applications, (b) evaluating the suitability of Diodes' products for their intended applications, (c) ensuring their applications, which incorporate Diodes' products, comply the applicable legal and regulatory requirements as well as safety and functional-safety related standards, and (d) ensuring they design with appropriate safeguards (including testing, validation, quality control techniques, redundancy, malfunction prevention, and appropriate treatment for aging degradation) to minimize the risks associated with their applications.
3. Diodes assumes no liability for any application-related information, support, assistance or feedback that may be provided by Diodes from time to time. Any customer or user of this document or products described herein will assume all risks and liabilities associated with such use, and will hold Diodes and all companies whose products are represented herein or on Diodes' websites, harmless against all damages and liabilities.
4. Products described herein may be covered by one or more United States, international or foreign patents and pending patent applications. Product names and markings noted herein may also be covered by one or more United States, international or foreign trademarks and trademark applications. Diodes does not convey any license under any of its intellectual property rights or the rights of any third parties (including third parties whose products and services may be described in this document or on Diodes' website) under this document.
5. Diodes' products are provided subject to Diodes' Standard Terms and Conditions of Sale (<https://www.diodes.com/about/company/terms-and-conditions/terms-and-conditions-of-sales/>) or other applicable terms. This document does not alter or expand the applicable warranties provided by Diodes. Diodes does not warrant or accept any liability whatsoever in respect of any products purchased through unauthorized sales channel.
6. Diodes' products and technology may not be used for or incorporated into any products or systems whose manufacture, use or sale is prohibited under any applicable laws and regulations. Should customers or users use Diodes' products in contravention of any applicable laws or regulations, or for any unintended or unauthorized application, customers and users will (a) be solely responsible for any damages, losses or penalties arising in connection therewith or as a result thereof, and (b) indemnify and hold Diodes and its representatives and agents harmless against any and all claims, damages, expenses, and attorney fees arising out of, directly or indirectly, any claim relating to any noncompliance with the applicable laws and regulations, as well as any unintended or unauthorized application.
7. While efforts have been made to ensure the information contained in this document is accurate, complete and current, it may contain technical inaccuracies, omissions and typographical errors. Diodes does not warrant that information contained in this document is error-free and Diodes is under no obligation to update or otherwise correct this information. Notwithstanding the foregoing, Diodes reserves the right to make modifications, enhancements, improvements, corrections or other changes without further notice to this document and any product described herein. This document is written in English but may be translated into multiple languages for reference. Only the English version of this document is the final and determinative format released by Diodes.
8. Any unauthorized copying, modification, distribution, transmission, display or other use of this document (or any portion hereof) is prohibited. Diodes assumes no responsibility for any losses incurred by the customers or users or any third parties arising from any such unauthorized use.
9. This Notice may be periodically updated with the most recent version available at <https://www.diodes.com/about/company/terms-and-conditions/important-notice>

The Diodes logo is a registered trademark of Diodes Incorporated in the United States and other countries.
All other trademarks are the property of their respective owners.
© 2024 Diodes Incorporated. All Rights Reserved.

www.diodes.com