

---

## AP3445/L EVB User Guide

---

AE Department

### 1. AP3445/L Revision Information

Date	Revision	Description	Comment
2017/10	V1.0	Initial Release	

### 2. AP3445/L General Description

The AP3445/L is a 2A step-down DC-DC converter. At heavy load, the constant frequency PWM control performs excellent stability and transient response. No external compensation components are required.

The AP3445/L supports a range of input voltages from 2.7V to 5.5V, allowing the use of a single Li+/Li-polymer cell, multiple Alkaline/NiMH cell, and other standard power sources. The output voltage is adjustable from 0.6V to the input voltage. The AP3445/L employs internal power switch and synchronous rectifier to minimize external part count and realize high efficiency. During shutdown, the input is disconnected from the output and the shutdown current is less than 1 $\mu$ A. Other key features include over-temperature and short circuit protection, and under-voltage lockout to prevent deep battery discharge.

The AP3445/L delivers 2A maximum output current while consuming only 55 $\mu$ A of no-load quiescent current. Ultra-low RDS(ON) integrated MOSFETs and 100% duty cycle operation make the AP3445/L an ideal choice for high output voltage, high current applications which require a low dropout threshold. Pulse skip mode allows to maintain high efficiency at light-load conditions.

The AP3445/L is available in TSOT23-6 package.

### 3. AP3445/L Key Features

- Output Current: Up to 2A
- Output Voltage: 0.6V to  $V_{IN}$
- Input Voltage: 2.7V to 5.5V
- 55  $\mu$ A (Typ) No Load Quiescent Current
- Shutdown Current: <1  $\mu$ A
- 100% Duty Cycle Operation
- 1MHz Switching Frequency
- Internal Soft Start
- No External Compensation Required
- Current Limit Protection
- Short Circuit Protection
- AP3445L: Latch Off Protection
- AP3445: Hiccup Mode Protection
- Over Voltage Protection
- AP3445L: Latch Off Protection
- AP3445: Non Latch Off Protection
- Thermal Shutdown

### 4. AP3445/L EV Board Schematic

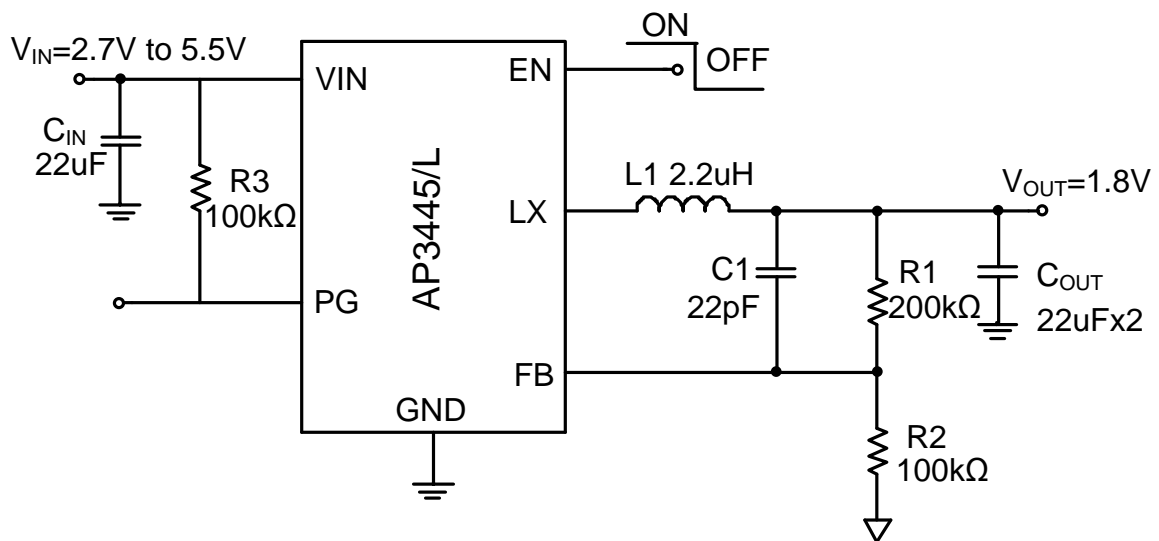

### 5. AP3445/L EV Board Description

AP3445 EV board is suitable evaluation board for the AP3445, a DC/DC converter. The board is targeted to be used in providing a simple and convenient evaluation environment for the AP3445. Requires parts, power supply connectors etc. on the board, which makes it easy to be evaluated.

## 6. AP3445/L EV Board View

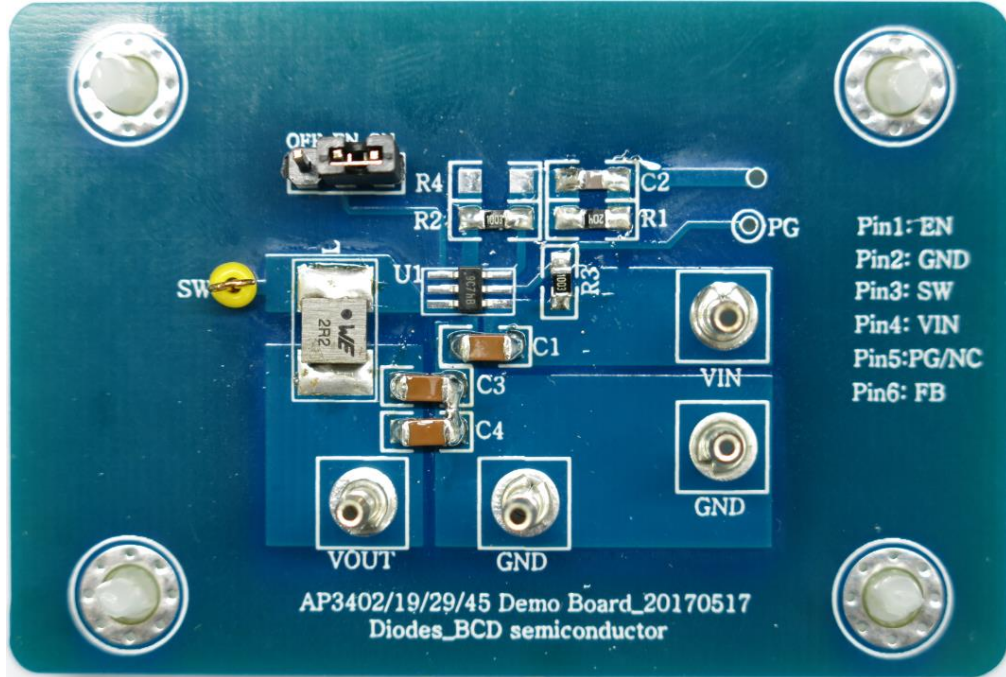

## 7. Setting the Output Voltage of AP3445/L

The output voltage is calculated as below:

$$V_{OUT} = 0.6 \times \left( \frac{R_1 + R_2}{R_2} \right)$$

First, select a value for R2, Then, R1 is determined. The output voltage is given by Table 1.

Vo	R1	R2	C3
1.0V	67KΩ	100 KΩ	22pF
1.2V	100KΩ	100 KΩ	22 pF
1.5V	150KΩ	100 KΩ	22 Pf
1.8V	200 KΩ	100 KΩ	22 pF
2.5V	317KΩ	100KΩ	22 pF
2.8V	367KΩ	100KΩ	22 pF
3.3V	450KΩ	100 KΩ	22 pF

Table 1: Resistor selection for output voltage setting

## 8. External Components Selection

### (1) Input & output Capacitors ( $C_{in}$ , $C_{out}$ )

- 1) For lower output ripple, low ESR is required.
- 2) Low leakage current needed, X5R/X7R ceramic recommend, multiple capacitor parallel connection.
- 3) The  $C_{in}$  and  $C_{out}$  capacitances are greater than 22 $\mu$ F and 44 $\mu$ F respective.

### (2) Output voltage programmer resistors ( $R_1$ , $R_2$ )

- 1) For programmer output voltage
- 2) For accurate output voltage, 1% tolerance is required.

### (3) Inductor (L)

- 1) Low DCR for good efficiency
- 2) Inductance saturate current must higher than the output current
- 3) The recommended inductance is shown in the table below.

$V_o$	Inductor			Würth PART
1.0V	1.0 $\mu$ H			74438357010
1.2V	1.0 $\mu$ H			74438357010
1.5V		1.5 $\mu$ H	2.2 $\mu$ H	74438357015
1.8V		1.5 $\mu$ H	2.2 $\mu$ H	74438357015
2.5V			2.2 $\mu$ H	74438357022
2.8V			2.2 $\mu$ H	74438357022
3.3V			2.2 $\mu$ H	74438357022

## 9. EV Board BOM List for AP3445/L

Item	Value	Type	Rating	Description	Description
C1	22uF	X5R/X7R, Ceramic/1206	10V	Input coupling CAP	
C3 & C4	22uF	X5R/X7R, Ceramic/1206	6.8V	Output coupling CAP	
L	2.2uH	4030	5.2A	Inductor	W irth PART 74438357022
R1	200K	0805	1%	Voltage set RES*	
R2	100K	0805	1%		
R3	100K	0805	1%	Power Good RES	
C2	22pF	0805		Feedback CAP	
U1		AP3445		TSOT23-6	Diodes BCD

\*Note: The present value of R1/R2 are based on  $V_{out}=1.8V$

## 10. Test Waveforms

Test condition:  $V_{in}=5.0V$   $V_o=1.8V$   $I_o=2.0A$

(Blue:  $V_{out-AC}$ ; Yellow:  $V_{sw}$ ; Green:  $I_L$ )

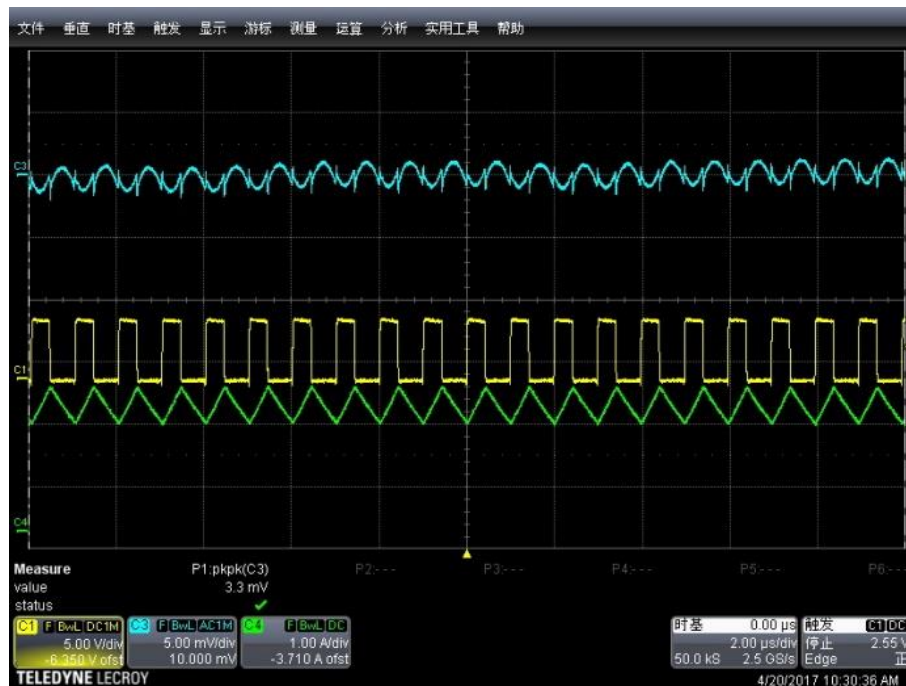

This EVB user guide contains new product information. Diodes, Inc. reserves the right to modify the product specification without notice. No liability is assumed as a result of the use of this product. No rights under any patent accompany the sale of the product.