

THROUGH-HOLE PACKAGING

REELS, TUBES, AMMO PACKS & TAPING SPECIFICATIONS

MINIMUM PACKAGING QUANTITY

MINIMUM PACKAGING QUANTITY					
Device Type	Available Packaging				
	Bulk			13"Ø Tape & Reel	Ammo Pack
	Quantity per Box	Quantity per Tube	Quantity per Tray	Quantity per Reel	Quantity per Box
5KP	500			500 / 700*	
5W	1K			3K	
5KW				1K	
A-405	1K			5K	3K
DF-M	5K	50			
DO-15	500 / 800 / 1K*			4K	2K
D0-201	1K			1K / 1.2K*	1K
DO-201AD	500/ 1K			1.2K	1K
DO-35	500			10K	5K / 10K*
DO-41	500 / 1K*			5K	3K / 5K*
E-LINE	4K				2K
GBJ	750	15			
GBPC/W			100		
GBU	1K	20			
KBJ	1K	20			
KBP	3.5K	35			
KBPC/W			100		
MB/W			100		
MP/W			100		
PBL			100		
PBPC-3			200		
PBPC-8	150				
PBU			100		
R-6	200 / 500*			500 / 700*	
T-1	1K			5K	3K
TO126	4K				
TO220AB/AC, ITO-220AB, ITO-220S, TO262	1K / 2K*	50			
TO220F	1K	50			
TO251	3K	75			
TO3P	1.2K	30			
TO92	2K / 5K / 10K*				2K / 4K*
TO92L					2K
WOG	1K				

* Quantity varies by Part Number.

- Notes:
1. Package quantities are given for minimum packaging quantity only, not minimum order quantity. For minimum order quantity, please consult the Sales Department.
 2. No mixed date codes or partial quantity (less than minimum packaging quantity) per packaging is allowed.
 3. In no case shall there be two or more consecutive components missing from any reel for any reason.

PRODUCT REEL DIMENSIONS

PRODUCT REEL					
Description	Symbol	Specification		Alternate	
		Inches	Millimeters	Inches	Millimeters
Arbor Hole Diameter	D_0	0.65 ± 0.02	16.6 ± 0.50	1.18 ± 0.02	30.0 ± 0.50
Core Diameter (O.D)	D_1	3.2 Typical	81.0 Typical	3.2 Typical	81.0 Typical
Reel Diameter	D_2	13.6 ± 0.6	345.0 ± 15.0	10.25 ± 0.6	260.0 ± 15.0
Drive Hole Diameter	D_3	0.38 ± 0.02	9.5 ± 0.5	0.38 ± 0.02	9.5 ± 0.5
Material Thickness	W_0	0.08 – 0.16	2.0 – 4.0	0.08 – 0.16	2.0 – 4.0
Reel Width	W_1	3.15 ± 0.20	80.0 ± 5.0	2.56 ± 0.20	65.0 ± 5.0
Drive/ Arbor Hole Spacing	W_2	1.08 ± 0.02	27.5 ± 0.5	1.08 ± 0.02	27.5 ± 0.5

Core material: plastic (blue/black) or metal (neutral)
 Reel material: corrugated board or plastic (blue or black)

For label dimensions and placement see AP02006.

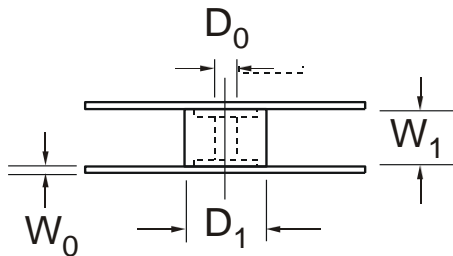

Direction of Unreeling

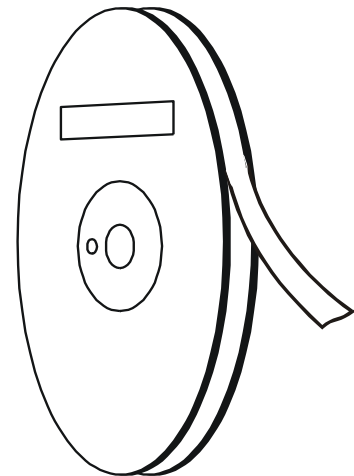
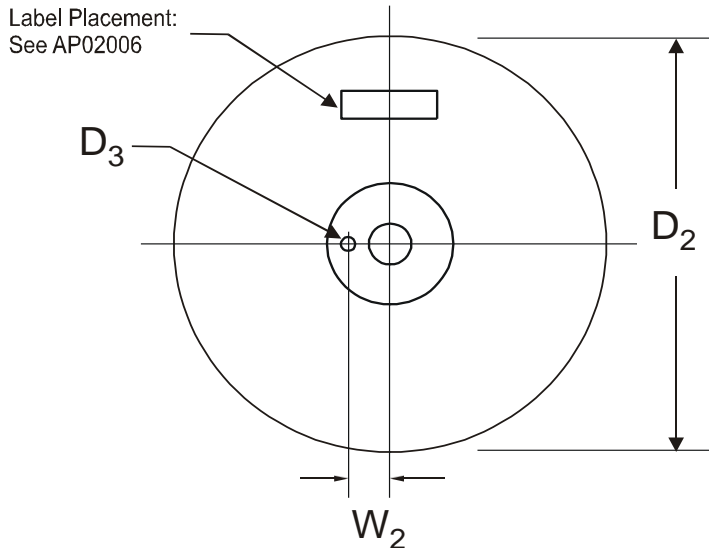

REEL/ AMMO PACK TAPING SPECIFICATIONS

REEL AND AMMO PACK TAPING SPECIFICATIONS			
Description	Symbol	Body	Specification (mm)
Component Pitch	A	DO-15, DO-35, DO-41, A-405, 5W	5.0 ± 0.5
		DO-201, DO-201AD, 5KP, 5KW, R-6	10.0 ± 0.5
Inside Tape Spacing	B	All	52.4 ± 1.5
Lead to Lead Eccentricity	$ D_1 - D_2 $	All	1.4 max
Lead Extension	K	All	0.8 max
Lead Bending	M	All	1.2 max
Cumulative Pitch	P	All	± 1.5 per 6 pitch
Exposed Adhesive	S	All	0.8 max
Tape Width	T	All	6.0 ± 0.4
Empty Spaces			$< 0.1\%$
Polarity Marking	<p>All polarized components shall be oriented in the same direction. The cathode tape shall be colored, and the anode tape shall be white or light beige. Anode end must face label-side of reel. See AP02006 for label placement.</p>		

Notes: 1. Consecutive missing components not allowed.

Dimensions A, M, K, P,
S, & T apply to both sides

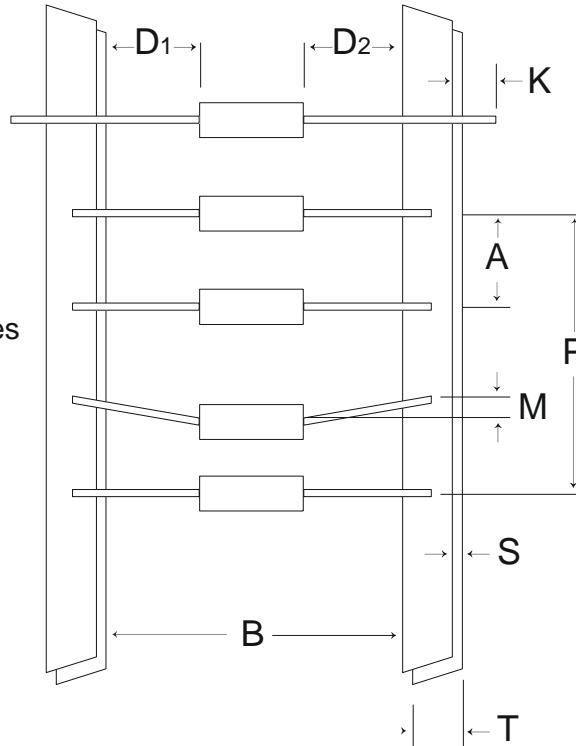

TUBE PACK DIMENSIONS/ SPECIFICATIONS

TUBE PACK							
PRODUCT DESCRIPTION	Height (H)		Width (W)		Length (L)		Drawing Reference
	inches	mm	inches	mm	inches	mm	
DF-M	0.6	15	0.5	13.3	17.5	444	
GBJ	1.7	42.5	0.3	7.2	18.7	475	
GBU	1.6	41.5	0.2	6.2	18.3	465	Fig.1
ITO-220AB	1.3	33	0.27	6.8	20.83	529	Fig.2
	1.26	32.09	0.26	6.75	21.02	534	Fig.3
ITO-220S	1.3	33	0.3	7	20.79	528	
KBJ	1.5	37.3	0.3	7.1	20.7	525	
KBP	1.2	29.6	0.2	6.2	20.9	531	
TO220AB	1.3	33	0.27	6.8	20.83	529	Fig.2
	1.26	32.09	0.26	6.75	21.02	534	Fig.3
TO220AC	1.3	33	0.3	7	20.79	528	
TO220-5	1.3	33	0.27	6.8	20.83	529	Fig.2
	1.26	32.09	0.26	6.75	21.02	534	Fig.3
TO3P, TO247	1.8	46	0.3	8	19.8	502	
TO262	1.3	33	0.3	7	20.79	528	

Fig.1

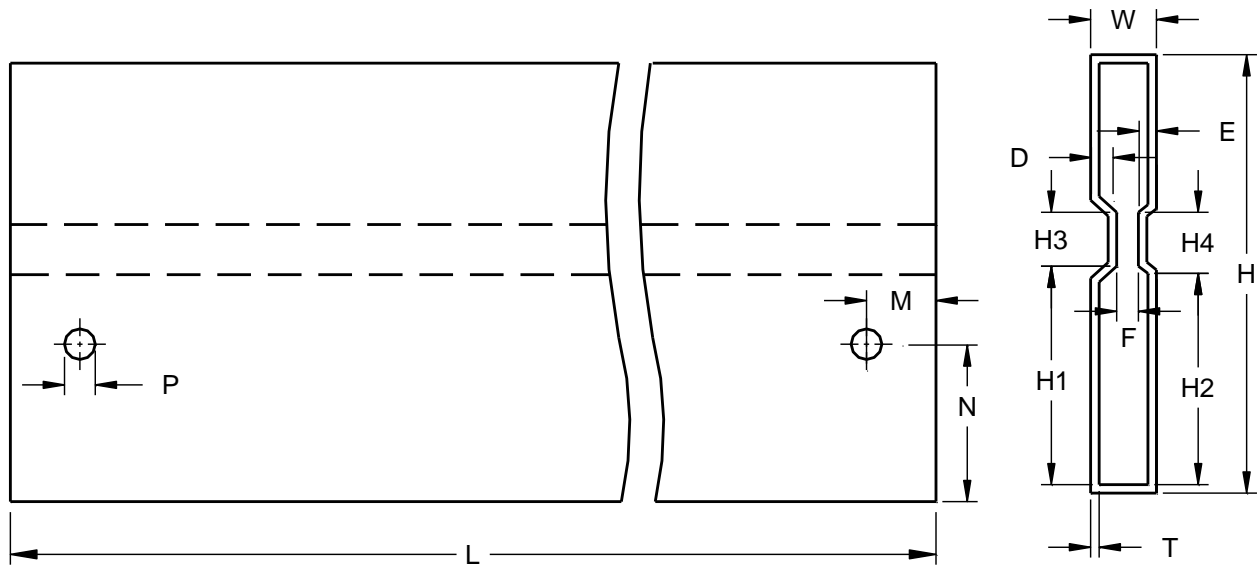

Dimension	Specification (mm)	Dimension	Specification (mm)	Dimension	Specification (mm)
D	2.45 ±0.1	H2	20.00±0.3	N	14.9 ±0.3
E	0.90 ±0.3	H3	5.10 ±0.3	P	2.90 ±0.1
F	2.05 +0.3/-0.1	H4	6.50±0.3	T	0.80 ±0.3
H	41.5±0.3	L	465+1/-0	W	6.20±0.2
H1	20.68±0.3	M	6.55±0.2		

Fig.2

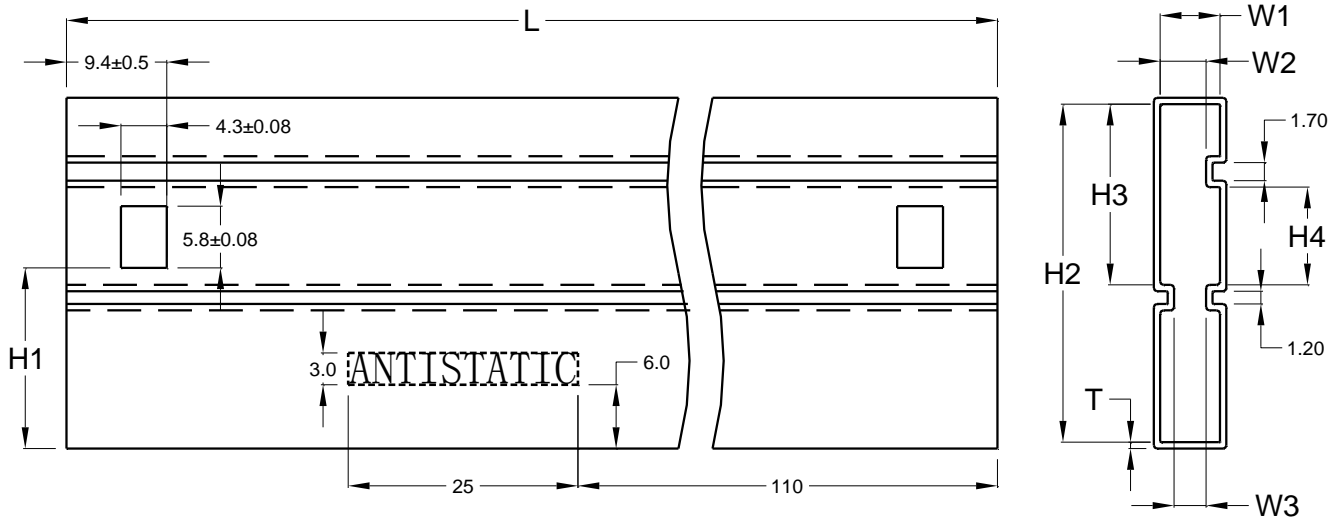

Dimension	Specification (mm)	Dimension	Specification (mm)
H1	17.00±0.3	W1	5.60±0.3
H2	31.80±0.5	W2	4.60±0.3
H3	17.00±0.3	W3	3.00±0.3
H4	9.20±0.3	T	0.60±0.2/-0.05
L	529.0±01.0		

Fig.3

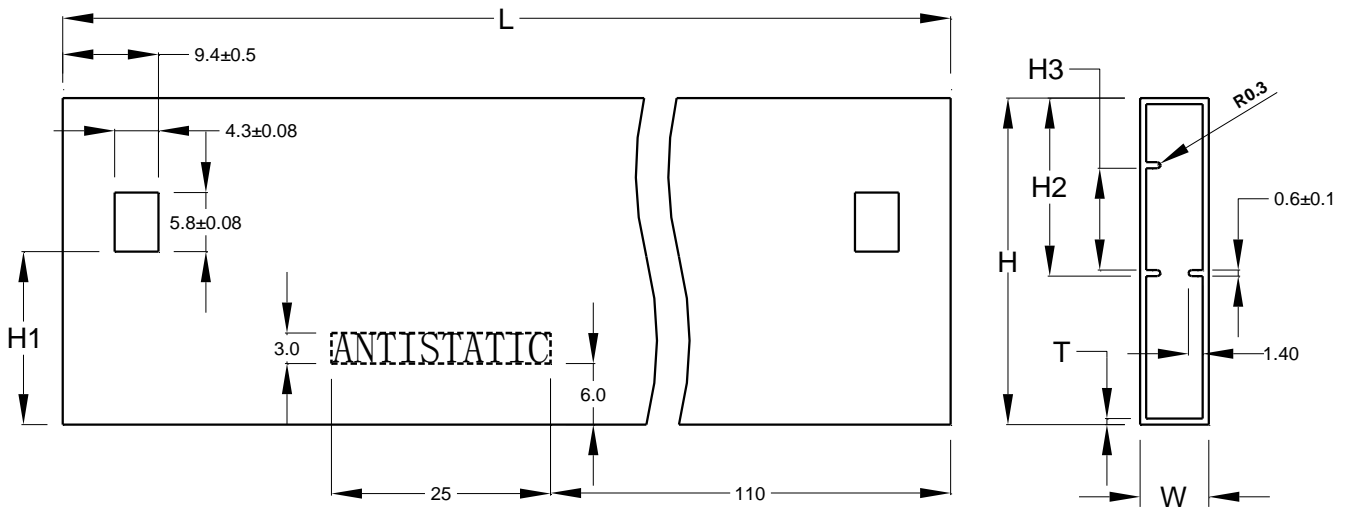

Dimension	Specification (mm)	Dimension	Specification (mm)
H	32.09±0.10	L	534.0±01.0
H1	17.00±0.3	W	6.75±0.25
H2	17.50±0.5	T	0.60±0.1
H3	10.00±0.5		

AMMO PACK DIMENSIONS/ SPECIFICATIONS

AMMO PACK						
PRODUCT DESCRIPTION	Height (H)		Width (W)		Length (L)	
	inches	mm	inches	mm	inches	mm
DO-35, DO-41 Glass Case	4.88	124	3.00	75	10.00	255
DO-41 Plastic Case	5.75	145	3.12	19	10.25	260
E-LINE	5.90	150	1.57	40	8.66	220
TO92	7.68	195	1.57	40	13.00	330

Material: corrugated board (neutral)
 Thickness: 3.00 ± 0.5mm (0.12 ± 0.02")
 For label dimensions and placement see AP02006.

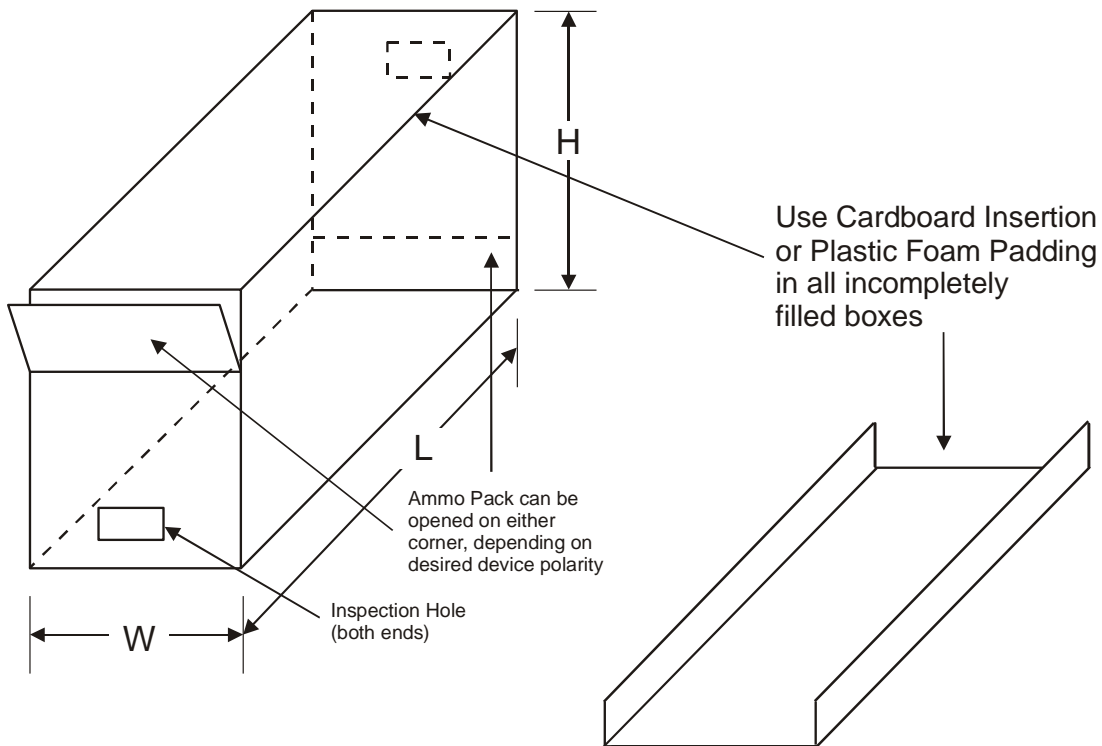

E-LINE TAPE AND AMMO PACKING

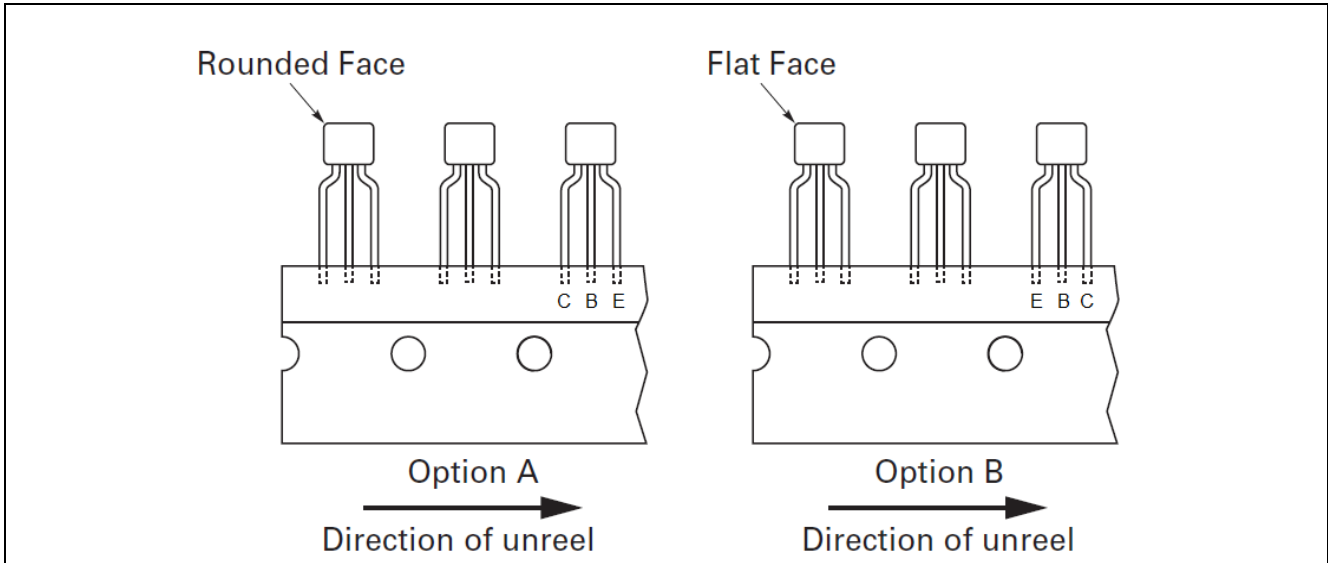

AMMO PACKING

Part No. suffixed STZ = 2,000 devices per box

Note: For **MOS** Pinout, substitute **C=D**, **B=G** and **E=S**

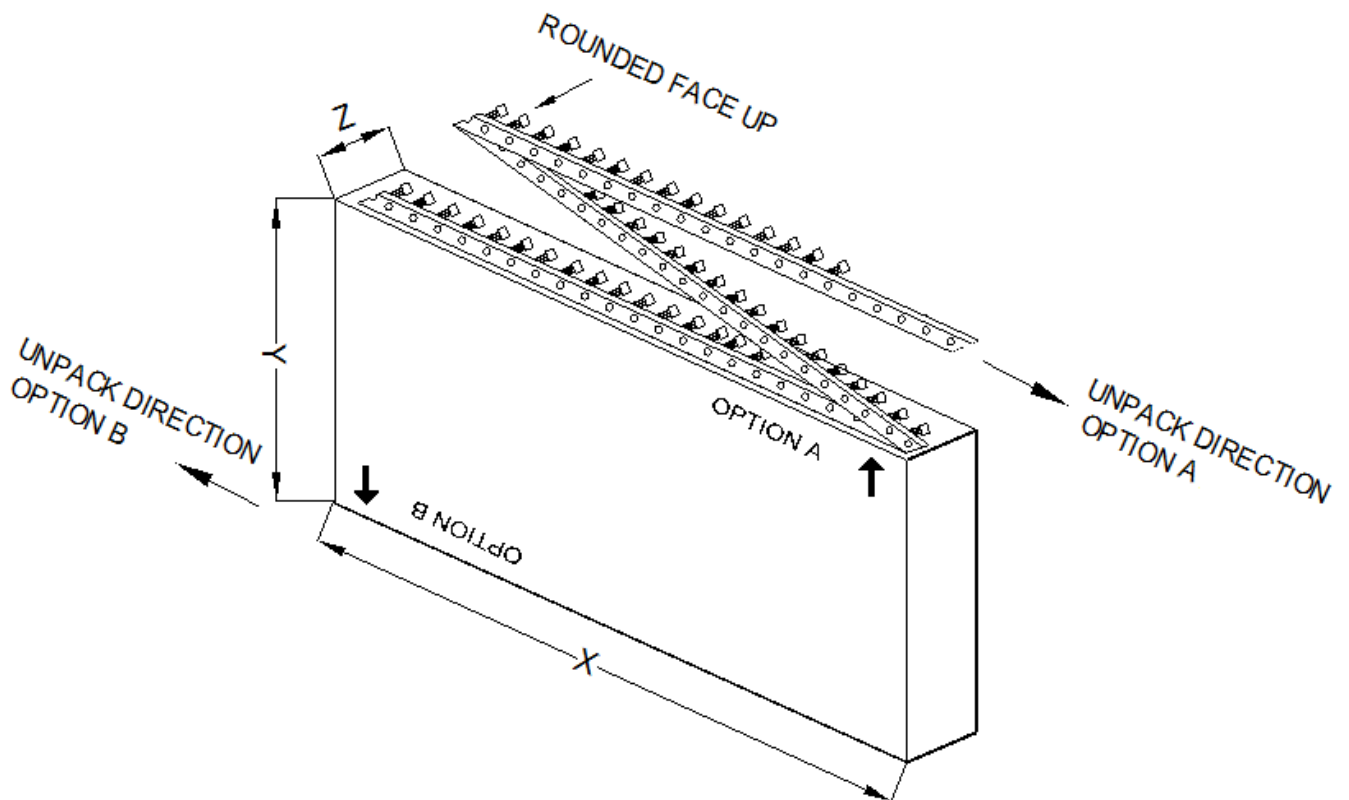

E-LINE AMMO TAPING SPECIFICATIONS

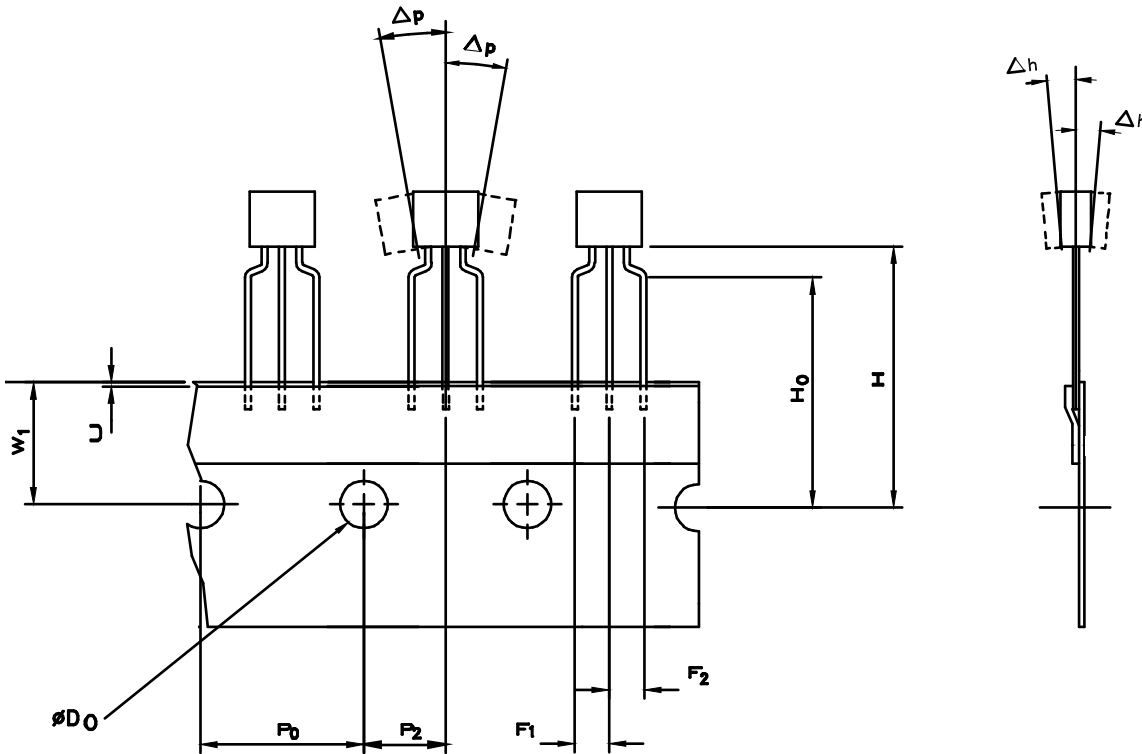

SYMBOL		ITEM DESCRIPTION	VALUE (mm)	
			Minimum	Maximum
1	ϕD_o	Sprocket hole not excessively burred	3.8	4.2
2	P_o	Pitch of sprocket hole	12.4	13.0
3	P_2	Distance between centre of sprocket hole and the middle lead of the following device.	5.95	6.75
4	F_1, F_2	Lead spacing of devices Note : F_1 & F_2 are to be measured from the top of the carrier tape	2.44	2.94
5	H	Distance between centre of sprocket hole and base of device body	18.0	20.0
6	$\Delta h, \Delta h$	Maximum deviation of the body vertical to the tape plane from the nominal position.	-2.0	2.0
7	$\Delta p, \Delta p$	Maximum deviation of the device body in the tape plane from the nominal position	-1.0	1.0
8	H_o	Distance between centre of sprocket hole to the reference plane of joggled devices	15.5	16.5
9	W_1	Distance from centre of sprocket hole to top of carrier tape.	8.5	9.5
10	U	Distance allowed below top of carrier tape by sealing tape.	0	0.5

TO92 TRANSISTOR – AMMO PACK

- Notes:
1. The carrier tape consists of a cardboard strip with sprocket holes. The pins of the transistors are secured radially to the carrier tape with a heat-seal tape.
 2. The tape can be taken from either of two opposite corners, depending on the desired pin sequence.
 3. The label shall contain a minimum of: Part Number, Type Designation, Quantity and Date Code.
 4. Each Ammo Pack consists of layers of 25 devices each, folded like a concertina. One component is missing at the end of each layer. Each such position is identified by means of a double perforation across the tape. The tape is folded at the perforations.
 5. See AP02006 for Label Dimensions and placement.

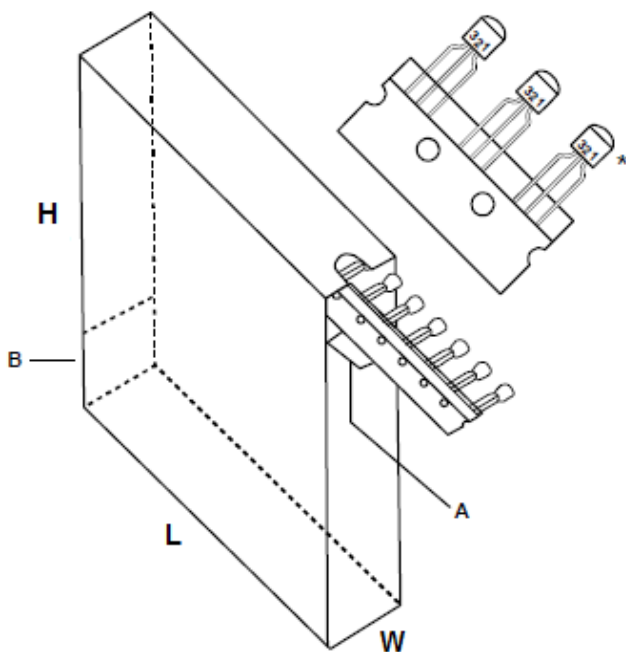

Position of the components when being withdrawn.

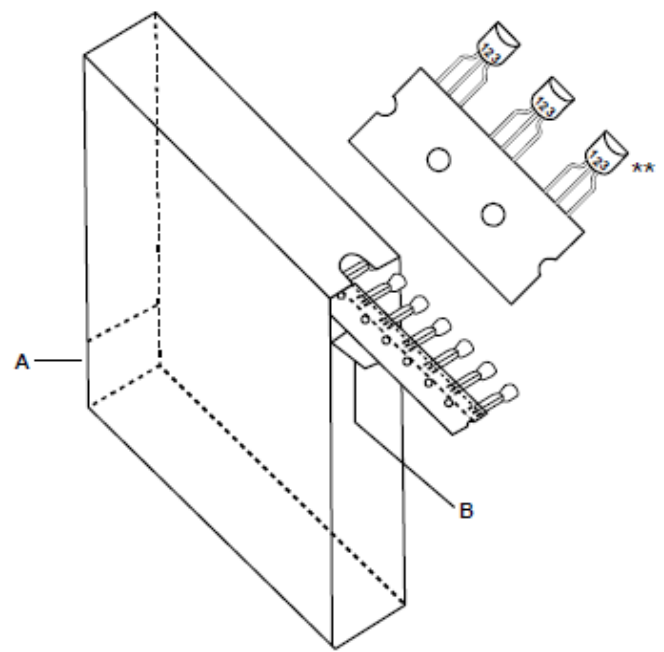

Position of the components when being withdrawn from opposite corner.

T092 TAPING SPECIFICATIONS

THROUGH-HOLE TO-92 TAPING SPECIFICATIONS		
Description	Symbol	Specification (mm)
Front to Rear Deflection	DA	0 ± 1.0
Left to Right Deflection	DB	0 ± 1.0
Feed Hole Diameter	D	4.0 ± 0.2
Component Lead Pitch	F1, F2	$2.5 +0.4$ $- 0.1$
Feed Hole to Bottom of Component	H	21.0 max
Height of Seating Plane	H1	16 ± 0.5
Height of Feed Hole Location	H2	$9.0 + 0.5$
Feed Hole Pitch	P	12.7 ± 0.3
Center of Seating Plane Location	P1	6.35 ± 0.5
Total Taped Package Thickness	T	1.5 max
Carrier Tape Width	W	$18.0 +1.0$ $- 0.5$
Adhesive Tape Width	W1	6.0 ± 0.5
Adhesive Tape Position	W2	1.0 max
Feed Hole Pitch Tolerance	—	0 ± 1.0 over 20 pitch
Empty Places in Tape	—	0.1%, non-consecutive

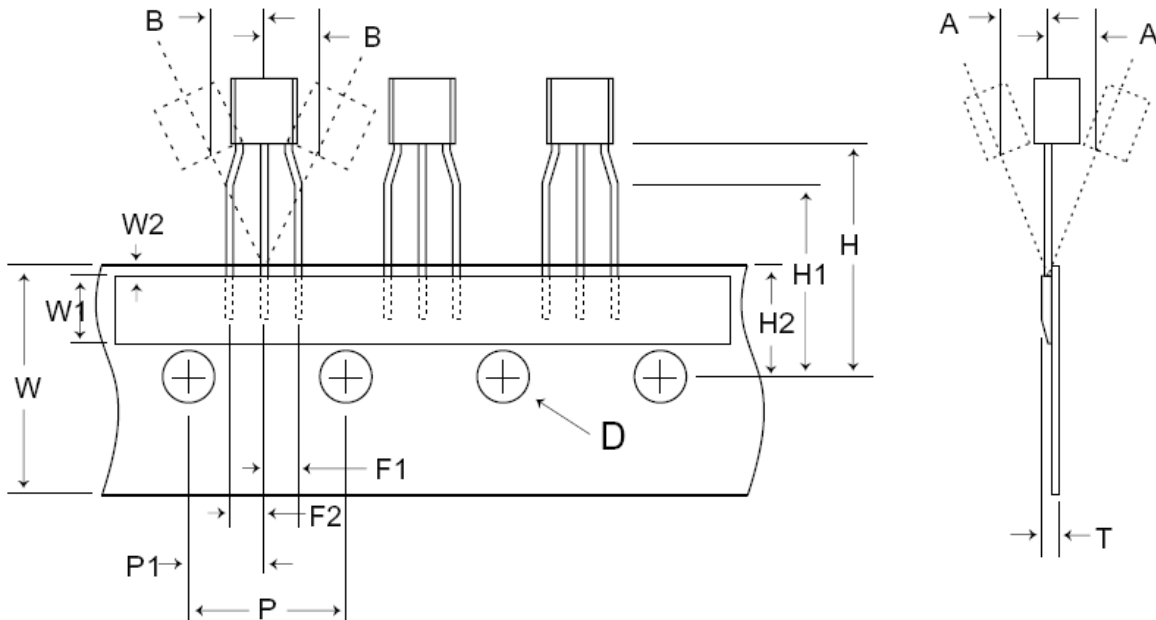

TO92L AMMO TAPING SPECIFICATION

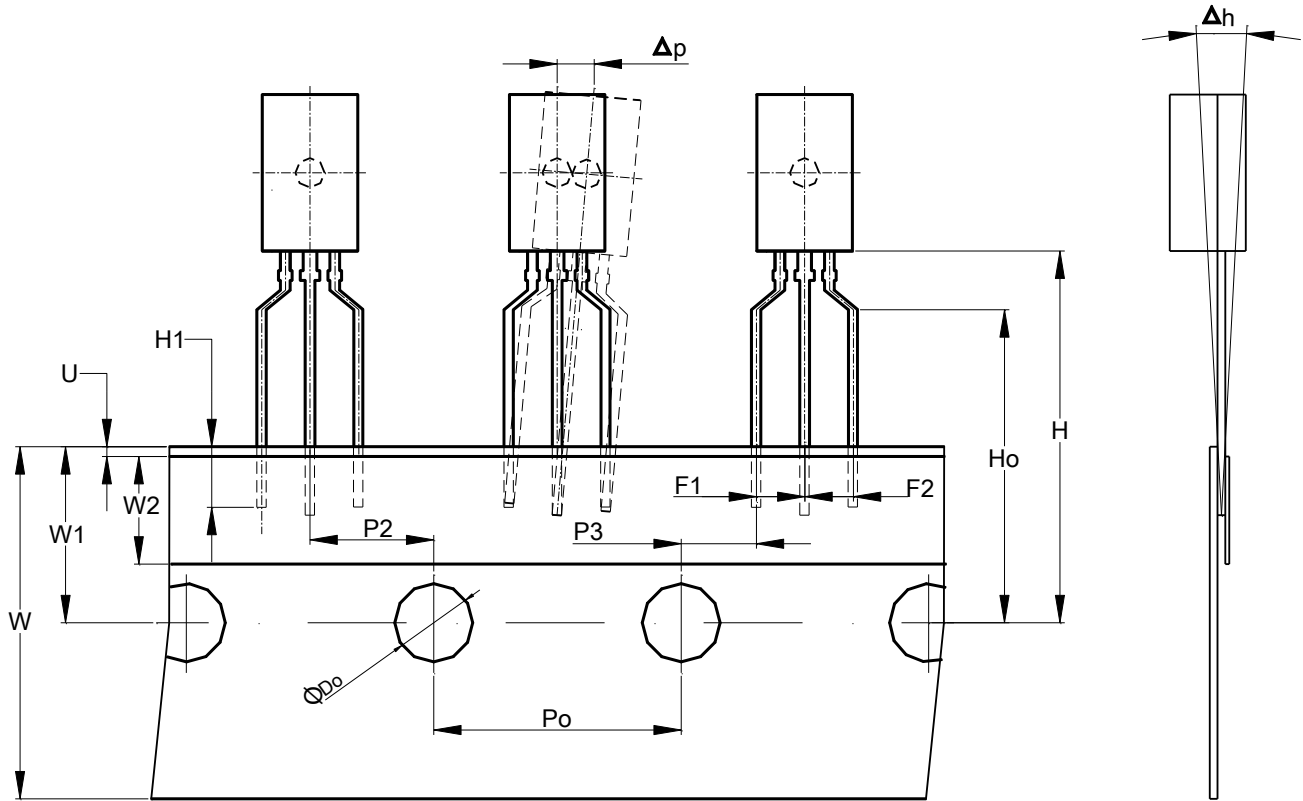

TO92L AMMO TAPING SPECIFICATIONS				
SYMBOL	ITEM DESCRIPTION	VALUE (mm)		
		MIN	MAX	TYP
ØDo	Sprocket hole not excessively burred	3.85	4.15	4.00
Po	Pitch of sprocket hole	12.60	12.80	12.70
P ₂	Distance between centre of sprocket hole and the centre of the middle lead of the adjacent device.	6.15	6.55	6.35
P ₃	Distance between centre of sprocket hole and the centre of the nearest lead of the adjacent device.	3.65	4.05	3.85
F ₁ , F ₂	Lead spacing of devices	2.30	2.70	2.50
H	Distance between centre of sprocket hole and base of device body	19.00	20.00	19.00
Ho	Distance between centre of sprocket hole to the reference plane of joggled devices	15.70	16.30	16.00
H ₁	Distance from the tip of the joggled leads to top of carrier tape	3.30	3.50	3.40
Δh	Maximum deviation of the body vertical to the tape plane from the nominal position.	-1.00	+1.00	0
Δp	Maximum deviation of the device body in the tape plane from the nominal position	-1.00	1.00	0
W	Width of tape	17.50	19.00	18.00
W ₁	Distance from centre of sprocket hole to top of carrier tape.	8.70	9.30	9.00
W ₂	Distance from top of carrier tape to bottom of sealing tape.	5.70	6.30	6.00
U	Distance allowed below top of carrier tape by sealing tape.	-	1.0	-