

**Low-Power 4-Output ZDB / Fanout Clock Buffer for PCIe 5.0 and UPI**

**Description**

The DIODES™ PI6CBE33045 is a low-power PCIe® 1.0/2.0/3.0/4.0/5.0 clock buffer. It takes a reference input to fanout four 100MHz low-power differential HCSL outputs with on-chip terminations for 85Ω output impedance. It supports both zero-delay and fanout buffer functions for various applications. An individual OE pin for each output provides easier power management.

It uses Diodes proprietary PLL design to achieve very-low jitter that meets PCIe 1.0/2.0/3.0/4.0/5.0 requirements.

**Block Diagram**

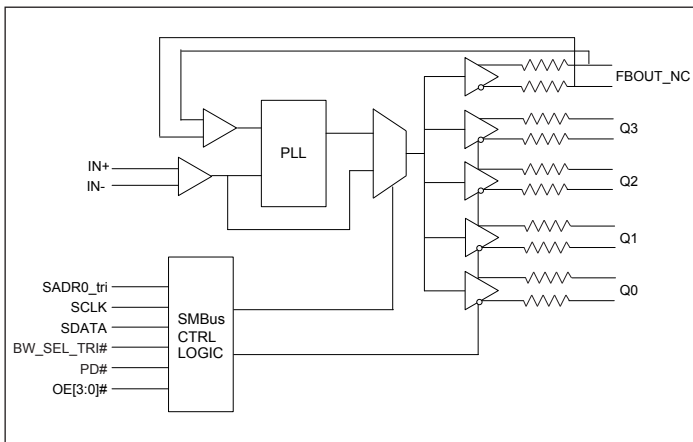

**Features**

- Four Differential Low-Power HCSL Outputs with On-Chip Termination
- Default  $Z_{OUT} = 85\Omega$
- Spread Spectrum Tolerant
- Individual Output Enable
- Selectable PLL Bandwidths
- Hardware/SMBus Control of ZDB and Fanout Buffer Modes
- 1–400MHz Fanout Buffer Operation
- Differential Output-to-output Skew <50ps
- Very Low Jitter Outputs
  - Differential Cycle-to-cycle Jitter <50ps
  - Fanout Buffer Mode Additive Phase Jitter:
    - PCIe 5.0 CC: 0.0074 ps
    - DB2000Q Additive Jitter: 0.02ps
  - ZDB Mode Phase Jitter:
    - PCIe 5.0 CC: RMS 0.02 ps
    - QPI/UPI 11.4GB/s: 0.14ps RMS
    - IF-UPI: RMS 0.15 ps
- Core Supply Voltage: 3.3V
- Totally Lead-Free & Fully RoHS Compliant (Notes 1 & 2)
- Halogen and Antimony Free. “Green” Device (Note 3)
- For automotive applications requiring specific change control (i.e. parts qualified to AEC-Q100/101/104/200, PPAP capable, and manufactured in IATF 16949 certified facilities), please [contact us](https://www.diodes.com/quality/product-definitions/) or your local Diodes representative.
- Packaging (Pb-free & Green):
  - 32-pin, 5mm × 5mm TQFN (ZH)

**Notes:**

1. No purposely added lead. Fully EU Directive 2002/95/EC (RoHS), 2011/65/EU (RoHS 2) & 2015/863/EU (RoHS 3) compliant.
2. See <https://www.diodes.com/quality/lead-free/> for more information about Diodes Incorporated’s definitions of Halogen- and Antimony-free, “Green” and Lead-free.
3. Halogen- and Antimony-free “Green” products are defined as those which contain <900ppm bromine, <900ppm chlorine (<1500ppm total Br + Cl) and <1000ppm antimony compounds.

## Pin Configuration

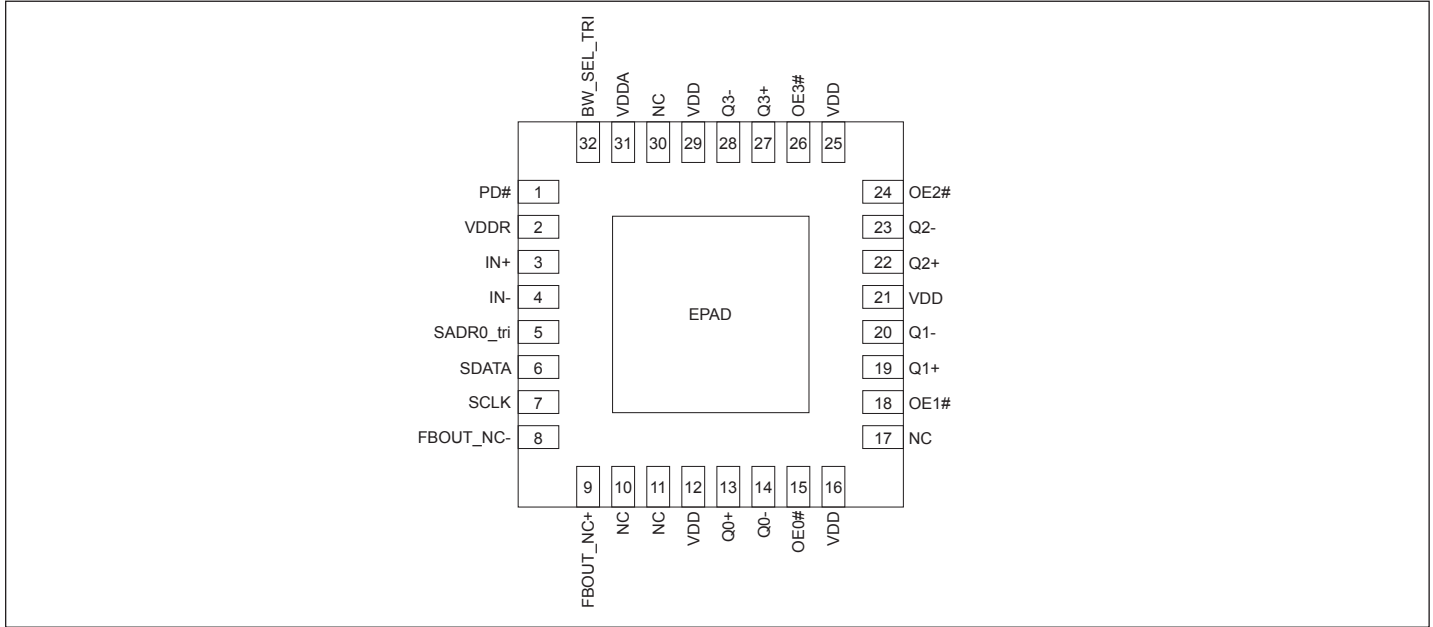

## Pin Description

Pin Number	Pin Name	Type		Description
1	PD#	Input	CMOS	Input notifies device to sample latched inputs and start up on first high assertion. Low enters Power Down Mode; subsequent high assertions exit Power Down Mode. This pin has internal pullup resistor.
2	VDDR	Power	—	Analog VDD for receiver
3	IN+	Input	HCSL	Differential true clock input
4	IN-	Input	HCSL	Differential complementary clock input
5	SADR0_tri	Input	Tri-level	Latch to select SMBus Address. This pin has an internal pulldown.
6	SDATA	Input/ Output	CMOS	SMBUS Data line, 3.3V tolerant
7	SCLK	Input	CMOS	SMBUS clock input, 3.3V tolerant
8	FBOUT_NC-	—	—	Complementary differential feedback output. This pin should NOT be connected to anything outside the chip. It exists to provide delay path matching to get zero propagation delay.
9	FBOUT_NC+	—	—	True differential feedback output. This pin should NOT be connected to anything outside the chip. It exists to provide delay path matching to get zero propagation delay.
10, 11, 17, 30	NC	—	—	Do not connect this pin.
12, 16, 21, 25, 29	V <sub>DD</sub>	Power	—	Power supply, nominal 3.3V
13	Q0+	Output	HCSL	Differential true clock output
14	Q0-	Output	HCSL	Differential complementary clock output

Pin Number	Pin Name	Type		Description
15	OE0#	Input	CMOS	Active low input for enabling Q0 pair. This pin has an internal pulldown. 1 =disable outputs, 0 = enable outputs
18	OE1#	Input	CMOS	Active low input for enabling Q1 pair. This pin has an internal pulldown. 1 =disable outputs, 0 = enable outputs
19	Q1+	Output	HCSL	Differential true clock output
20	Q1-	Output	HCSL	Differential complementary clock output
22	Q2+	Output	HCSL	Differential true clock output
23	Q2-	Output	HCSL	Differential complementary clock output
24	OE2#	Input	CMOS	Active low input for enabling Q2 pair. This pin has an internal pulldown. 1 =disable outputs, 0 = enable outputs
26	OE3#	Input	CMOS	Active low input for enabling Q3 pair. This pin has an internal pulldown. 1 =disable outputs, 0 = enable outputs
27	Q3+	Output	HCSL	Differential true clock output
28	Q3-	Output	HCSL	Differential complementary clock output
31	VDDA	Power	—	Analog VDD
32	BW_SEL_TRI	Input	Tri-level	Latch to select low-loop bandwidth, bypass PLL, and high-loop bandwidth. This pin has internal pullup resistor
EPAD	EPAD	Power	—	Connect to ground

### Power Management Table

PD#	IN	SMBus OE bit	OEn#	Qn+	Qn-	PLL Status
0	X	X	X	Low	Low	Off
1	Running	0	X	Low	Low	On <sup>(1)</sup>
1	Running	1	0	Running	Running	On <sup>(1)</sup>
1	Running	1	1	Low	Low	On <sup>(1)</sup>

Note:

1. If PLL Bypass mode is selected, the PLL will be off and outputs will be running.

### PLL Operating Mode Select Table

BW_SEL_TRI	Operating Mode	PLL
0	PLL with Low Bandwidth	Running
M	PLL Bypass	Off
1	PLL with High Bandwidth	Running

## Maximum Ratings

(Above which useful life may be impaired. For user guidelines, not tested.)

Storage Temperature.....	-65°C to +150°C
Supply Voltage to Ground Potential, $V_{DDxx}$ .....	-0.5V to +4.6V
Input Voltage .....	-0.5V to $V_{DD}+0.5V$ , not exceed 4.6V
SMBus, Input High Voltage .....	3.6V
ESD Protection (HBM) .....	2000 V
Junction Temperature .....	125°C max

**Note:**  
Stresses greater than those listed under MAXIMUM RATINGS may cause permanent damage to the device. This is a stress rating only and functional operation of the device at these or any other conditions above those indicated in the operational sections of this specification is not implied. Exposure to absolute maximum rating conditions for extended periods may affect reliability.

## Operating Conditions

Temperature =  $T_A$ ; Supply voltages per normal operation conditions; See test circuits for the load conditions

Symbol	Parameters	Conditions	Min.	Typ.	Max.	Units
$V_{DD}, V_{DDA}, V_{DDR}$	Power Supply Voltage	—	3.135	3.3	3.465	V
$I_{DDA}$	Analog Power Supply Current	$V_{DDA}$ , PLL mode, All outputs active @ 100MHz	—	21	25	mA
$I_{DD}$	Power Supply Current	$V_{DD} + V_{DD-R}$ , All outputs active @ 100MHz	—	70	85	mA
$I_{DDA\_PD}$	Analog Power Supply Power Down <sup>(1)</sup> Current	$V_{DDA}$ , PLL mode, All outputs LOW/LOW	—	0.6	1	mA
$I_{DD\_PD}$	Power Supply Power Down <sup>(1)</sup> Current	$V_{DD} + V_{DD-R}$ , All outputs LOW/LOW	—	2.5	3	mA
$T_A$	Ambient Temperature	Industrial grade	-40	—	85	°C

**Note:**  
1. Input clock is not running.  
2. Outputs drive 5 inch trace.

## Input Electrical Characteristics

Symbol	Parameters	Conditions	Min.	Typ.	Max.	Units
$R_{pu}$	Internal Pullup Resistance	—	—	120	—	K $\Omega$
$R_{dn}$	Internal Pulldown Resistance	—	—	120	—	K $\Omega$
$L_{PIN}$	Pin Inductance	—	—	—	7	nH

### SMBus Electrical Characteristics

 Temperature =  $T_A$ ; Supply voltages per normal operation conditions; See test circuits for the load conditions

Symbol	Parameters	Conditions	Min.	Typ.	Max.	Units
$V_{DDSMB}$	Nominal Bus Voltage	—	2.7	—	3.6	V
$V_{IHSMB}$	SMBus Input High Voltage	SMBus, $V_{DDSMB} = 3.3V$	2.1	—	3.6	V
		SMBus, $V_{DDSMB} < 3.3V$	0.65* $V_{DDSMB}$	—	—	
$V_{ILSMB}$	SMBus Input Low Voltage	SMBus, $V_{DDSMB} = 3.3V$	—	—	0.8	V
		SMBus, $V_{DDSMB} < 3.3V$	—	—	0.8	
$I_{SMBSINK}$	SMBus Sink Current	SMBus, at $V_{OLSMB}$	4	—	—	mA
$V_{OLSMB}$	SMBus Output Low Voltage	SMBus, at $I_{SMBSINK}$	—	—	0.4	V
$f_{MAXSMB}$	SMBus Operating Frequency	Maximum frequency	—	—	500	kHz
$t_{RMSB}$	SMBus Rise Time	(Max $V_{IL} - 0.15$ ) to (Min $V_{IH} + 0.15$ )	—	—	1000	ns
$t_{FMSB}$	SMBus Fall Time	(Min $V_{IH} + 0.15$ ) to (Max $V_{IL} - 0.15$ )	—	—	300	ns

### LVC MOS DC Electrical Characteristics

 Temperature =  $T_A$ ; Supply voltages per normal operation conditions; See test circuits for the load conditions

Symbol	Parameters	Conditions	Min.	Typ.	Max.	Units
$V_{IH}$	Input High Voltage	Single-ended inputs, except SMBus	0.75* $V_{DD}$	—	$V_{DD} + 0.3$	V
$V_{IM}$	Input Mid Voltage	SADR0_TRI, SADR1_TRI, BW_SEL_TRI	0.4 $V_{DD}$	0.5 $V_{DD}$	0.6 $V_{DD}$	V
$V_{IL}$	Input Low Voltage	Single-ended inputs, except SMBus	-0.3	—	0.25 $V_{DD}$	V
$I_{IH}$	Input High Current	Single-ended inputs, $V_{IN} = V_{DD}$	—	—	5	$\mu A$
$I_{IL}$	Input Low Current	Single-ended inputs, $V_{IN} = 0V$	-5	—	—	$\mu A$
$I_{IH}$	Input High Current	Single-ended inputs with pullup/pulldown resistor, $V_{IN} = V_{DD}$	—	—	50	$\mu A$
$I_{IL}$	Input Low Current	Single-ended inputs with pullup/pulldown resistor, $V_{IN} = 0V$	-50	—	—	$\mu A$
$C_{IN}$	Input Capacitance	—	1.5	—	5	pF

### LVC MOS AC Electrical Characteristics

 Temperature =  $T_A$ ; Supply voltages per normal operation conditions; See test circuits for the load conditions

Symbol	Parameters	Conditions	Min.	Typ.	Max.	Units
$t_{OELAT}$	Output Enable Latency	Q start after OE# assertion Q stop after OE# deassertion	4	5	10	clocks
$t_{PDLAT}$	PD# Deassertion	Differential outputs enable after PD# deassertion	—	20	300	$\mu s$

## HCSSL Input Characteristics<sup>(1)</sup>

Temperature = T<sub>A</sub>; Supply voltages per normal operation conditions; See test circuits for the load conditions

Symbol	Parameters	Conditions	Min.	Typ.	Max.	Units
V <sub>IHDIF</sub>	Diff. Input High Voltage <sup>(3)</sup>	IN+, IN-, single-end measurement	600	800	1150	mV
V <sub>ILDIF</sub>	Diff. Input Low Voltage <sup>(3)</sup>	IN+, IN-, single-end measurement	-300	0	300	mV
V <sub>COM</sub>	Diff. Input Common Mode Voltage	—	150	—	900	mV
V <sub>SWING</sub>	Diff. Input Swing Voltage	Peak to peak value (V <sub>IHDIF</sub> - V <sub>ILDIF</sub> )	300	—	2900	mV
f <sub>INBP</sub>	Input Frequency	PLL Bypass mode	1	—	400	MHz
f <sub>IN100</sub>	Input Frequency	100MHz PLL	98.5	100	102.5	MHz
f <sub>MODI-PCIe</sub>	Input SS Modulation Freq. PCIe	Allowable frequency for PCIe applications (Triangular Modulation)	30	—	33	kHz
t <sub>STAB</sub>	Clock stabilization	From V <sub>DD</sub> Power-Up and after input clock stabilization or de-assertion of PD# to 1st clock	—	0.75	1.0	ms
t <sub>RF</sub>	Diff. Input Slew Rate <sup>(2)</sup>	Measured differentially with 10 inch trace. Please refer to test load Figure 1.	0.4	—	—	V/ns
I <sub>IN</sub>	Diff. Input Leakage Current	V <sub>IN</sub> = V <sub>DD</sub> , V <sub>IN</sub> = GND	-5	0.01	5	uA
t <sub>DC</sub>	Diff. Input Duty Cycle	Measured differentially	45	—	55	%
t <sub>jC-c</sub>	Diff. Input Cycle to cycle jitter	Measured differentially	—	—	125	ps

**Note:**

1. Guaranteed by design and characterization, not 100% tested in production
2. Slew rate measured through +/-75mV window centered around differential zero
3. The device can be driven by a single-ended clock by driving the true clock and biasing the complement clock input to the V<sub>bias</sub>, where V<sub>bias</sub> is (V<sub>IH</sub>-V<sub>IL</sub>)/2

## HCSSL Output DC Characteristics

Temperature = T<sub>A</sub>; Supply voltages per normal operation conditions; See test circuits for the load conditions

Symbol	Parameters	Condition	Min.	Typ.	Max.	Units
V <sub>OH</sub>	Output Voltage High <sup>(1)</sup>	Statistical measurement on single-ended signal using oscilloscope math function	660	—	850	mV
V <sub>OL</sub>	Output Voltage Low <sup>(1)</sup>		-150	—	150	mV
V <sub>OMAX</sub>	Output Voltage Maximum <sup>(1)</sup>	Measurement on single ended signal using absolute value	—	—	1150	mV
V <sub>OMIN</sub>	Output Voltage Minimum <sup>(1)</sup>		-300	—	—	mV
V <sub>OC</sub>	Output Cross Voltage <sup>(1,2,4)</sup>	—	250	—	550	mV
DV <sub>OC</sub>	V <sub>OC</sub> Magnitude Change <sup>(1,2,5)</sup>	—	—	—	140	mV

**Note:**

1. At default SMBUS amplitude settings.
2. Guaranteed by design and characterization—not 100% tested in production.
3. Measured from differential waveform.
4. This one is defined as voltage where Q+ = Q- measured on a component test board and only applied to the differential rising edge.
5. The total variation of all V<sub>cross</sub> measurements in any particular system. This is a subset of V<sub>cross\_min/max</sub> allowed.

## HC SL Output AC Characteristics

Temperature = T<sub>A</sub>; Supply voltages per normal operation conditions; See test circuits for the load conditions

Symbol	Parameters	Condition	Min.	Typ.	Max.	Units
f <sub>OUT</sub>	Output Frequency	PLL mode 100MHz	98.5	100	102.5	MHz
		PLL bypass mode	1	—	400	MHz
BW	PLL Bandwidth <sup>(1,8)</sup>	-3dB point in High Bandwidth Mode	2	2.65	4	MHz
		-3dB point in Low Bandwidth Mode	0.7	1.1	1.4	MHz
t <sub>jpeak</sub>	PLL Jitter Peaking	Peak pass band gain, low bandwidth	0	1.2	2	dB
		Peak pass band gain, high bandwidth	0	1.2	2.5	dB
t <sub>RF</sub>	Slew Rate <sup>(1,2,3)</sup>	Scope averaging on fast setting with 10 inch trace. Please refer to test load Figure 1.	2.2	3	4.0	V/ns
D <sub>tRF</sub>	Slew Rate Matching <sup>(1,2,4)</sup>	Scope averaging on	—	8	20	%
t <sub>SKEW</sub>	Output Skew <sup>(1,2)</sup>	Averaging on, V <sub>T</sub> = 50%	—	30	50	ps
t <sub>DC</sub>	Duty Cycle <sup>(1,2)</sup>	Measured differentially, PLL Mode	45	50	55	%
t <sub>DCD</sub>	Duty Cycle Distortion <sup>(1,7)</sup>	Measured differentially, PLL Bypass Mode at 100MHz	-3.5	0	3.5	%
t <sub>j-c</sub>	Cycle-to-Cycle Jitter <sup>(1,2)</sup>	PLL mode	—	14	50	ps
		Additive jitter, Bypass mode	—	0.1	1	ps
t <sub>pd_PLL</sub>	Propagation delay	Input to output propagation delay in PLL mode at 100MHz with nominal temperature and voltage	-100	15	100	ps
t <sub>pd_BY P</sub>	Propagation delay	Input to output propagation delay in ByPass mode at 100MHz with nominal temperature and voltage	1650	2150	2650	ps



### HCSSL Output AC Characteristics (PLL Mode PCIe Phase Jitter)

Symbol	Parameters	Condition	Min.	Typ.	Max.	Spec Limit	Units
t <sub>JPH_PLL_CC</sub>	Integrated Phase Jitter PLL Mode (RMS) <sup>(1,5)</sup> Low Bandwidth (Common Clocked Architecture)	PCIe 1.0 <sup>(6)</sup>	—	2.5	5	86	ps (p-p)
		PCIe 2.0 Low Band	—	0.025	0.05	3.1	ps
		PCIe 2.0 High Band	—	0.161	0.18	3	ps
		PCIe 3.0	—	0.051	0.071	1	ps
		PCIe 4.0	—	0.051	0.071	0.5	ps
		PCIe 5.0 <sup>(11)</sup>	—	0.02	0.026	0.15	ps
t <sub>JPH_PLL_SRIS</sub>	Integrated Phase Jitter PLL Mode (RMS) <sup>(1,5)</sup> Low Bandwidth (SRIS Architecture)	PCIe 1.0	—	7.8	8.7	—	ps (p-p)
		PCIe 2.0	—	0.139	0.208	—	ps
		PCIe 3.0	—	0.061	0.12	—	ps
		PCIe 4.0	—	0.062	0.12	—	ps
		PCIe 5.0 <sup>(11)</sup>	—	0.016	0.032	—	ps
t <sub>JPH_PLL_CC</sub>	Integrated Phase Jitter PLL Mode (RMS) <sup>(1,5)</sup> High Bandwidth (Common Clocked Architecture)	PCIe 1.0 <sup>(6)</sup>	—	5.1	6.5	86	ps (p-p)
		PCIe 2.0 Low Band	—	0.026	0.052	3.1	ps
		PCIe 2.0 High Band	—	0.18	0.24	3	ps
		PCIe 3.0	—	0.053	0.063	1	ps
		PCIe 4.0	—	0.053	0.063	0.5	ps
		PCIe 5.0 <sup>(11)</sup>	—	0.021	0.031	0.15	ps
t <sub>JPH_PLL_SRIS</sub>	Integrated Phase Jitter PLL Mode (RMS) <sup>(1,5)</sup> High Bandwidth (SRIS Architecture)	PCIe 1.0	—	7.51	8.12	—	ps (p-p)
		PCIe 2.0	—	0.153	0.198	—	ps
		PCIe 3.0	—	0.067	0.087	—	ps
		PCIe 4.0	—	0.07	0.09	—	ps
		PCIe 5.0 <sup>(11)</sup>	—	0.014	0.028	—	ps

**Note:**

- Guaranteed by design and characterization—not 100% tested in production.
- Measured from differential waveform.
- Slew rate is measured through the V<sub>swing</sub> voltage range centered around differential 0V, within ±150mV window.
- Slew rate matching is measured through ±75mV window centered around differential zero.
- See <http://www.pcisig.com> for complete specs.
- Sample size of at least 100k cycles. This can be extrapolated to 108ps pk-pk @ 1M cycles for a BER of 10<sup>-12</sup>.
- Duty cycle distortion is the difference in duty cycle between the output and input clock when the device is operated in the PLL bypass mode.
- The Min and Max values of each BW setting track each other, low BW max will never occur with high BW min.
- Applies to all differential outputs.
- For additive jitter RMS value is calculated by the following equation = SQRT [(total jitter)<sup>2</sup> - (input jitter)<sup>2</sup>].
- PCIe 5.0 v0.9 specification.

### HCSSL Output AC Characteristics (Fanout Buffer Mode Additive Phase Jitter)

Symbol	Parameters	Condition	Min.	Typ.	Max.	Output Limit	Units
t <sub>JPH_A_CC</sub>	Additive Integrated Phase Jitter (RMS) <sup>(1,5)</sup> (Common Clocked Architecture)	PCIe 1.0 <sup>(6)</sup>	—	1.2	1.8	86	ps (p-p)
		PCIe 2.0 Low Band	—	0.004	0.015	3	ps
		PCIe 2.0 High Band	—	0.058	0.087	3.1	ps
		PCIe 3.0	—	0.019	0.0228	1	ps
		PCIe 4.0	—	0.019	0.0228	0.5	ps
		PCIe 5.0 <sup>(11)</sup>	—	0.0074	0.0174	0.15	ps
t <sub>JPH_A_SRIS</sub>	Additive Integrated Phase Jitter (RMS) <sup>(1,5,10)</sup> (SRIS Architecture)	PCIe 1.0	—	0.111	0.154	—	ps (p-p)
		PCIe 2.0	—	0.051	0.09	—	ps
		PCIe 3.0	—	0.022	0.042	—	ps
		PCIe 4.0	—	0.023	0.043	—	ps
		PCIe 5.0 <sup>(11)</sup>	—	0.006	0.026	—	ps
t <sub>JPH_A_12k-20M</sub>	Additive Integrated Phase Jitter (RMS) <sup>(1,5,10)</sup> 12kHz ~ 20MHz	100MHz, SSC off	—	0.086	0.111	—	ps

**Note:**

1. Guaranteed by design and characterization—not 100% tested in production.
2. Measured from differential waveform.
3. Slew rate is measured through the V<sub>swing</sub> voltage range centered around differential 0V, within ±150mV window.
4. Slew rate matching is measured through ±75mV window centered around differential zero.
5. See <http://www.pcisig.com> for complete specs.
6. Sample size of at least 100k cycles. This can be extrapolated to 108ps pk-pk @ 1M cycles for a BER of 10<sup>-12</sup>.
7. Duty cycle distortion is the difference in duty cycle between the output and input clock when the device is operated in the PLL bypass mode.
8. The Min and Max values of each BW setting track each other, low BW max will never occur with high BW min.
9. Applies to all differential outputs.
10. For additive jitter RMS value is calculated by the following equation = SQRT [(total jitter)<sup>\*2</sup> - (input jitter)<sup>\*2</sup>].
11. PCIe 5.0 v0.9 specification.

### HCSSL Output Filtered Phase Jitter (QPI\_UPI/DB2000Q)

Symbol	Parameters	Condition	Min.	Typ.	Max.	Spec Limit	Units
tjPHPLL_ QPI_UPI	Integrated Phase Jitter PLL Mode (RMS) <sup>(1,5)</sup>	QPI and UPI, 100M or 133.33MHz, 4.8Gbps, 6.4Gbps 12UI	—	0.18	0.38	0.5	ps
		QPI and UPI, 100MHz, 8.0Gbps, 12UI	—	0.17	0.2	0.3	ps
		QPI and UPI, 100MHz, <11.4Gbps, 12UI	—	0.14	0.16	0.2	ps
tjPH_QPI_ UPI	Fanout Buffer Mode Additive Integrated Phase Jitter (RMS) <sup>(1,5,10)</sup>	QPI and UPI, 100M or 133.33MHz, 4.8Gbps, 6.4Gbps 12UI	—	0.06	0.08	—	ps (p-p)
		QPI and UPI, 100MHz, 8.0Gbps, 12UI	—	0.06	0.08	—	ps
		QPI and UPI, 100MHz, <11.4Gbps, 12UI	—	0.03	0.06	—	ps
tjPH_IFUPI	PLL Mode IF-UPI phase jitter	Low bandwidth	—	0.15	0.18	1	ps
		High bandwidth	—	0.18	0.22	1	ps
	Fanout Buffer Mode IF-UPI phase jitter	—	—	0.08	0.1	1	ps
tjPH_ DB2000Q	Fanout Buffer Mode DB2000Q phase jitter	—	—	0.02	0.03	0.08	ps

**Note:**

1. Guaranteed by design and characterization—not 100% tested in production.
2. Measured from differential waveform.
3. Slew rate is measured through the Vswing voltage range centered around differential 0V, within ±150mV window.
4. Slew rate matching is measured through ±75mV window centered around differential zero.
5. See <http://www.pcisig.com> for complete specs.
6. Sample size of at least 100k cycles. This can be extrapolated to 108ps pk-pk @ 1M cycles for a BER of 10<sup>-12</sup>.
7. Duty cycle distortion is the difference in duty cycle between the output and input clock when the device is operated in the PLL bypass mode.
8. The Min and Max values of each BW setting track each other, low BW max will never occur with high BW min.
9. Applies to all differential outputs.
10. For additive jitter RMS value is calculated by the following equation = SQRT [(total jitter)<sup>2</sup> - (input jitter)<sup>2</sup>].
11. PCIe 5.0 v0.9 specification.

## SMBus Serial Data Interface

PI6CBE33045 is a slave-only device that supports block read and block write protocol using a single 7-bit address and read/write bit as shown below.

Read and write block transfers can be stopped after any complete byte transfer.

### Address Assignment

A6	A5	A4	A3	A2	A1	A0	R/W
1	1	0	1	1	0	0	1/0

Note: SMBus address is latched on SADR pin

### SMBus Address

Pin		SMBus Address			
SADR1_tri	SADR0_tri	PI6CBE3312x	PI6CBE3308x	PI6CBE3306x	PI6CBE33045
0	0	D8	D8	D8	D8
0	M	DA	N/A	N/A	DA
0	1	DE	N/A	N/A	DE
M	0	C2	N/A	N/A	N/A
M	M	C4	N/A	N/A	N/A
M	1	C6	N/A	N/A	N/A
1	0	CA	N/A	N/A	N/A
1	M	CC	N/A	N/A	N/A
1	1	CE	N/A	N/A	N/A

Note: PI6CBE3308x and PI6CBE3306x do not have SMBus address select pins. Their address is D8.

### How to Write

1 bit	7 bits	1 bit	1 bit	8 bits	1 bit	8 bits	1 bit	8 bits	1 bit		8 bits	1 bit	1 bit
Start bit	Add.	W(0)	Ack	Beginning Byte location = N	Ack	Data Byte count = X	Ack	Beginning Data Byte (N)	Ack	.....	Data Byte (N+X-1)	Ack	Stop bit

### How to Read

1 bit	7 bits	1 bit	1 bit	8 bits	1 bit	1 bit	7 bits	1 bit	1 bit	8 bits	1 bit	8 bits	1 bit
Start bit	Address	W(0)	Ack	Beginning Byte location = N	Ack	Repeat Start bit	Address	R(1)	Ack	Data Byte count = X	Ack	Beginning Data Byte (N)	Ack

											8 bits	1 bit	1 bit
.....											Data Byte (N+X-1)	NACK	Stop bit

### Byte 0: PLL Operating Mode and Frequency Select Register

Bit	Control Function	Description	Type	Power-up Condition	0	1
7	PLLMODERB1	PLL Mode Readback Bit1	R	Latch	00 = Low BW ZDB 01= Fanout mode 10 = Reserved 11 = High BW ZDB	
6	PLLMODERB0	PLL Mode Readback Bit0	R	Latch		
5	Reserved	—		0	—	—
4	Reserved	—		0	—	—
3	PLL SW Control	PLL Mode control Bit0	RW <sup>(1)</sup>	0	Hardware Latch	SMBus Control
2	PLL mode	PLL Mode 1	RW	1	00 = Low BW ZDB 01= Fanout mode 10 = Reserved 11 = High BW ZDB	
1	PLL mode	PLL Mode 0	RW	1		
0	Frequency Select RB	Frequency select readback	R	Latch	133MHz	100MHz

### Byte 1: Output Enable Register 1

Bit	Control Function	Description	Type	Power-up Condition	0	1
7	Reserved		RW	0		
6	Q2_OE	Q2 output enable	RW	1	Output Low/ Low	OE Pin Control
5	Q1_OE	Q1 output enable	RW	1	Output Low/ Low	OE Pin Control
4	Reserved	—	RW	0	—	—
3	Reserved	—	RW	0	—	—
2	Q0_OE	Q0 output enable	RW	1	Output Low/ Low	OE Pin Control
1	Reserved	—	RW	0	—	—
0	Reserved	—	RW	0	—	—

### Byte 2: Output Enable Register 2

Bit	Control Function	Description	Type	Power-up Condition	0	1
7	Reserved	—	RW	0	—	—
6	Reserved	—	RW	0	—	—
5	Reserved	—	RW	0	—	—
4	Reserved	—	RW	0	—	—
3	Reserved	—	RW	0	—	—
2	Reserved	—	RW	0	—	—
1	Q3_OE	Q3 output enable	RW	1	Output Low/ Low	OE Pin Control
0	Reserved	—	RW	0	—	—

### Byte 3 and Byte 4: Reserved

### Byte 5: Revision and Vendor ID Register

Bit	Control Function	Description	Type	Power-up Condition	0	1
7	RID3	Revision ID	R	0	rev = 0000	
6	RID2		R	0		
5	RID1		R	0		
4	RID0		R	0		
3	PVID3	Vendor ID	R	0	Diodes = 0011	
2	PVID2		R	0		
1	PVID1		R	1		
0	PVID0		R	1		

### Byte 6: Device ID Register

Bit	Control Function	Description	Type	Power-up Condition
7	NA	DID7	R	0hB1
6		DID6	R	
5		DID5	R	
4		DID4	R	
3		DID3	R	
2		DID2	R	
1		DID1	R	
0		DID0	R	

### Byte 7: Byte Count Register

Bit	Control Function	Description	Type	Power-up Condition	0	1
7	Reserved	—		0	—	—
6	Reserved	—		0	—	—
5	Reserved	—		0	—	—
4	BC4	Writing to the register configures how many bytes will be read back on a block read	RW	0	—	—
3	BC3		RW	1	—	—
2	BC2		RW	0	—	—
1	BC1		RW	0	—	—
0	BC0		RW	0	—	—

**Test Loads**

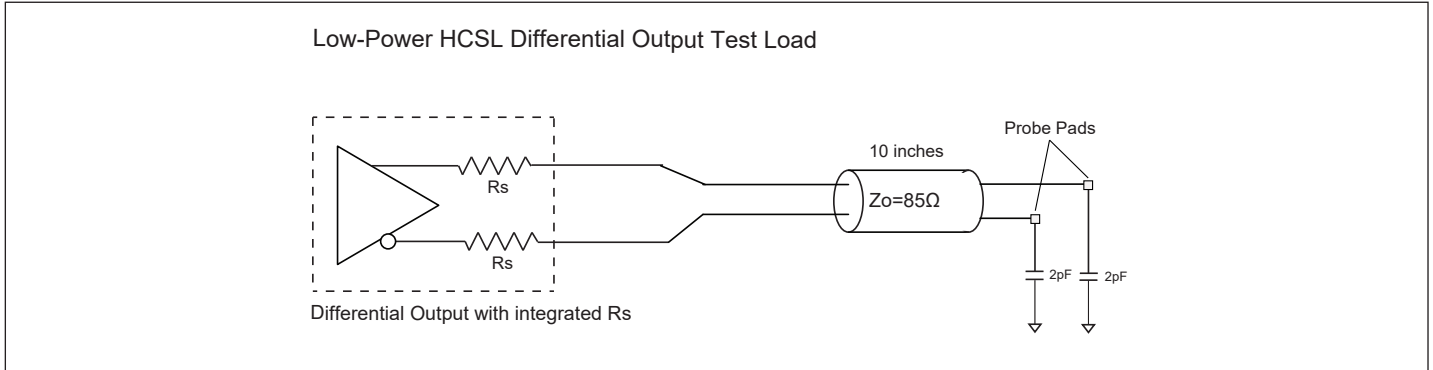

**Figure 1. Low-Power HCSL Test Circuit"**

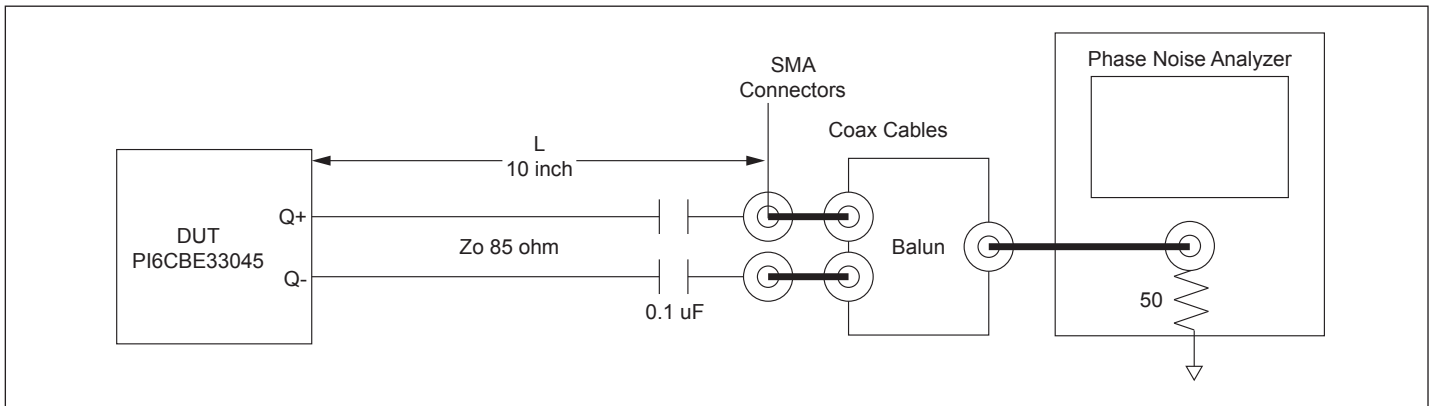

**Figure 2. Test Set Up for Phase Jitter Measurement**

**LVDS Output Termination Table**

Component	Receiver with Termination	Receiver without Termination	Unit
R <sub>1a</sub> , R <sub>1b</sub>	10,000	130	Ω
R <sub>2a</sub> , R <sub>2b</sub>	5600	64	Ω
C <sub>C</sub>	0.1	0.1	μF
V <sub>CM</sub>	1.2	1.2	V



### LVDS Output Termination

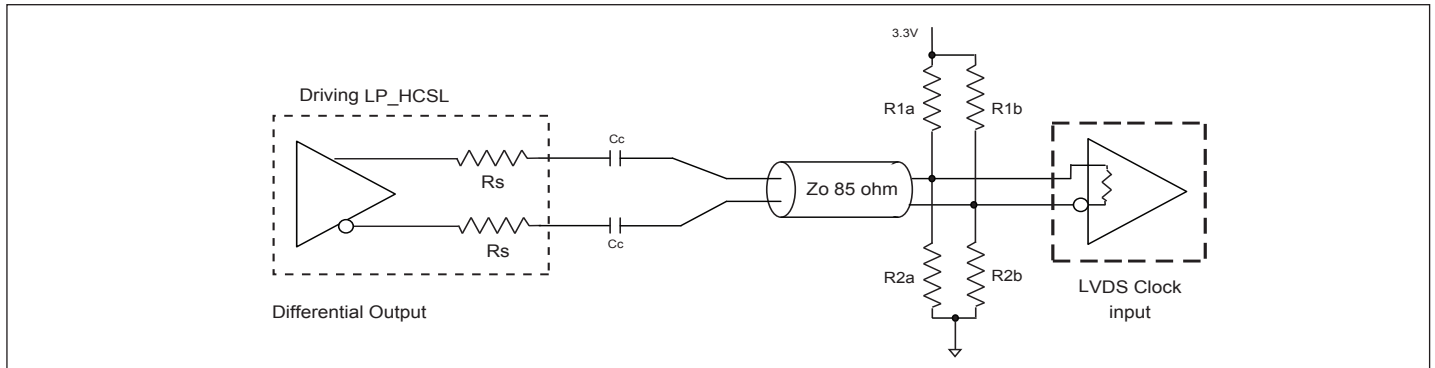

**Figure 3. Differential Output Driving LVDS**

### Power Supply

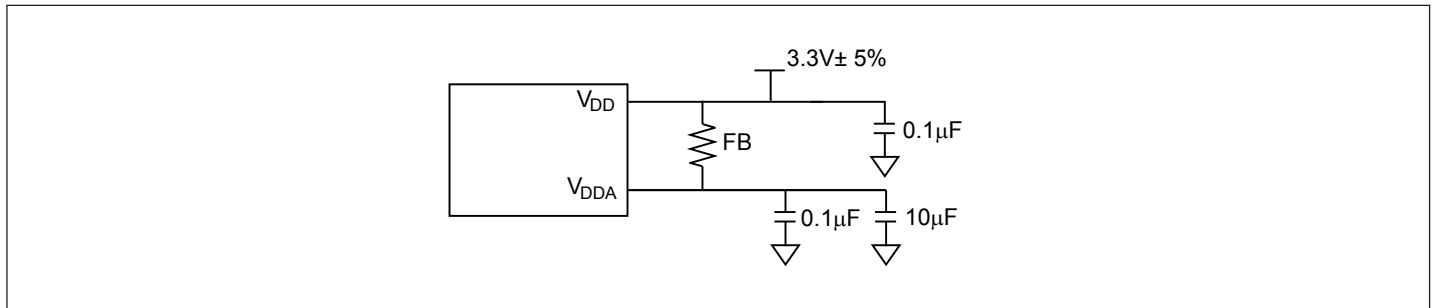

**Figure 4. Power Supply Filter**

### Thermal Characteristics Table

Symbol	Parameter	Conditions	Min.	Typ.	Max.	Unit
$\theta_{JA}$	Thermal Resistance Junction to Ambient	Still air		34.4		°C/W
$\theta_{JC}$	Thermal Resistance Junction to Case			15		°C/W

### Part Marking

PI6CBE33  
045ZHIE  
ZYYWWXX  
○

Z: Die Rev  
YY: Date Code (Year)  
WW: Date Code (Workweek)  
1st X: Assembly Site Code  
2nd X: Wafer Fab Site Code  
Bar above Fab Code means Cu Wire

**Packaging Mechanical**

**32-TQFN (ZH)**

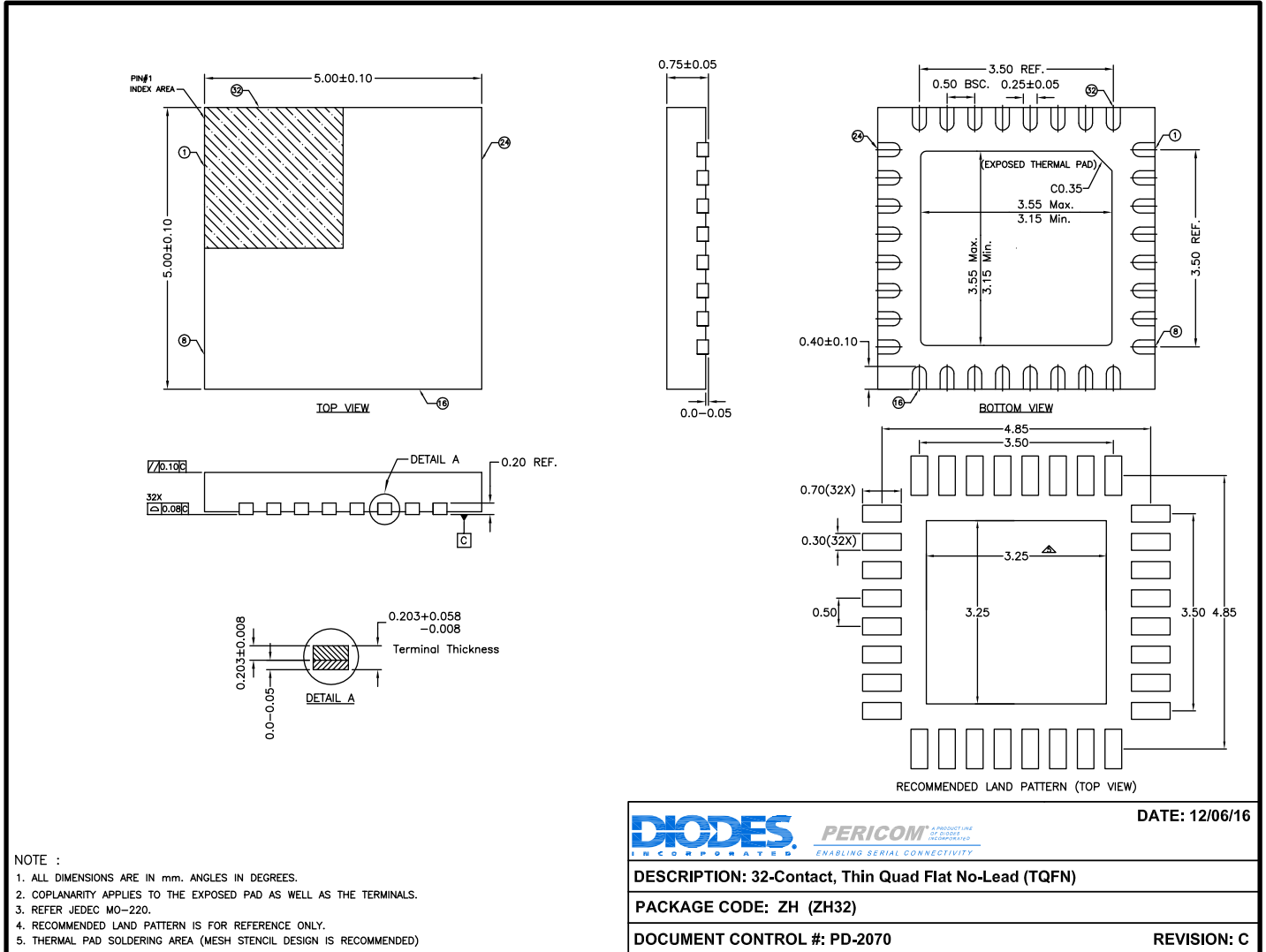

17-0570

**For latest package information:**

See <http://www.diodes.com/design/support/packaging/pericom-packaging/packaging-mechanicals-and-thermal-characteristics/>.

## Ordering Information

Ordering Code	Package Code	Package Description	Temperature	Pin 1 Orientation
PI6CBE33045ZHIEX	ZH	32-Contact, Thin Quad Flat No-Lead (TQFN)	-40~85°C	Top Right Corner
PI6CBE33045ZHIEX-13R	ZH	32-Contact, Thin Quad Flat No-Lead (TQFN)	-40~85°C	Top Left Corner

**Notes:**

1. No purposely added lead. Fully EU Directive 2002/95/EC (RoHS), 2011/65/EU (RoHS 2) & 2015/863/EU (RoHS 3) compliant.
2. See <https://www.diodes.com/quality/lead-free/> for more information about Diodes Incorporated's definitions of Halogen- and Antimony-free, "Green" and Lead-free.
3. Halogen- and Antimony-free "Green" products are defined as those which contain <900ppm bromine, <900ppm chlorine (<1500ppm total Br + Cl) and <1000ppm antimony compounds.
4. I = Industrial
5. E = Pb-free and Green
6. X suffix = Tape/Reel
7. For packaging detail, go to our website at: <https://www.diodes.com/assets/MediaList-Attachments/Diodes-Package-Information.pdf>

## Pin 1 Orientation

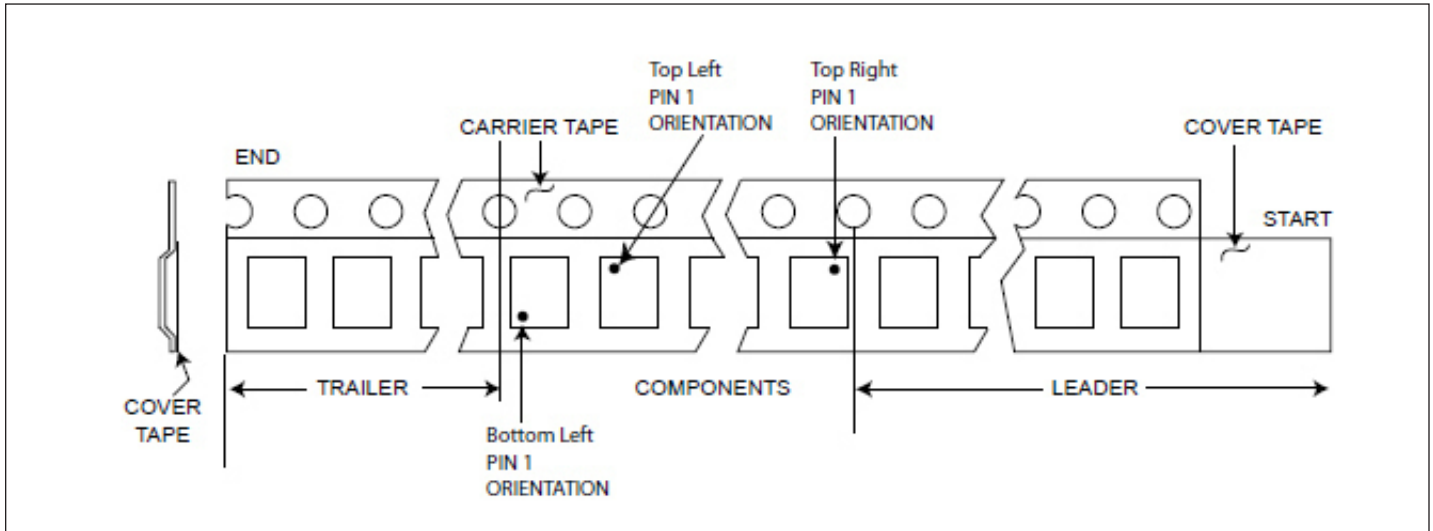

**IMPORTANT NOTICE**

1. DIODES INCORPORATED (Diodes) AND ITS SUBSIDIARIES MAKE NO WARRANTY OF ANY KIND, EXPRESS OR IMPLIED, WITH REGARDS TO ANY INFORMATION CONTAINED IN THIS DOCUMENT, INCLUDING, BUT NOT LIMITED TO, THE IMPLIED WARRANTIES OF MERCHANTABILITY, FITNESS FOR A PARTICULAR PURPOSE OR NON-INFRINGEMENT OF THIRD PARTY INTELLECTUAL PROPERTY RIGHTS (AND THEIR EQUIVALENTS UNDER THE LAWS OF ANY JURISDICTION).

2. The Information contained herein is for informational purpose only and is provided only to illustrate the operation of Diodes' products described herein and application examples. Diodes does not assume any liability arising out of the application or use of this document or any product described herein. This document is intended for skilled and technically trained engineering customers and users who design with Diodes' products. Diodes' products may be used to facilitate safety-related applications; however, in all instances customers and users are responsible for (a) selecting the appropriate Diodes products for their applications, (b) evaluating the suitability of Diodes' products for their intended applications, (c) ensuring their applications, which incorporate Diodes' products, comply the applicable legal and regulatory requirements as well as safety and functional-safety related standards, and (d) ensuring they design with appropriate safeguards (including testing, validation, quality control techniques, redundancy, malfunction prevention, and appropriate treatment for aging degradation) to minimize the risks associated with their applications.

3. Diodes assumes no liability for any application-related information, support, assistance or feedback that may be provided by Diodes from time to time. Any customer or user of this document or products described herein will assume all risks and liabilities associated with such use, and will hold Diodes and all companies whose products are represented herein or on Diodes' websites, harmless against all damages and liabilities.

4. Products described herein may be covered by one or more United States, international or foreign patents and pending patent applications. Product names and markings noted herein may also be covered by one or more United States, international or foreign trademarks and trademark applications. Diodes does not convey any license under any of its intellectual property rights or the rights of any third parties (including third parties whose products and services may be described in this document or on Diodes' website) under this document.

5. Diodes' products are provided subject to Diodes' Standard Terms and Conditions of Sale (<https://www.diodes.com/about/company/terms-and-conditions/terms-and-conditions-of-sales/>) or other applicable terms. This document does not alter or expand the applicable warranties provided by Diodes. Diodes does not warrant or accept any liability whatsoever in respect of any products purchased through unauthorized sales channel.

6. Diodes' products and technology may not be used for or incorporated into any products or systems whose manufacture, use or sale is prohibited under any applicable laws and regulations. Should customers or users use Diodes' products in contravention of any applicable laws or regulations, or for any unintended or unauthorized application, customers and users will (a) be solely responsible for any damages, losses or penalties arising in connection therewith or as a result thereof, and (b) indemnify and hold Diodes and its representatives and agents harmless against any and all claims, damages, expenses, and attorney fees arising out of, directly or indirectly, any claim relating to any noncompliance with the applicable laws and regulations, as well as any unintended or unauthorized application.

7. While efforts have been made to ensure the information contained in this document is accurate, complete and current, it may contain technical inaccuracies, omissions and typographical errors. Diodes does not warrant that information contained in this document is error-free and Diodes is under no obligation to update or otherwise correct this information. Notwithstanding the foregoing, Diodes reserves the right to make modifications, enhancements, improvements, corrections or other changes without further notice to this document and any product described herein. This document is written in English but may be translated into multiple languages for reference. Only the English version of this document is the final and determinative format released by Diodes.

8. Any unauthorized copying, modification, distribution, transmission, display or other use of this document (or any portion hereof) is prohibited. Diodes assumes no responsibility for any losses incurred by the customers or users or any third parties arising from any such unauthorized use.

9. This Notice may be periodically updated with the most recent version available at <https://www.diodes.com/about/company/terms-and-conditions/important-notice>

The Diodes logo is a registered trademark of Diodes Incorporated in the United States and other countries.

DIODES is a trademark of Diodes Incorporated in the United States and other countries.

All other trademarks are the property of their respective owners.

© 2023 Diodes Incorporated. All Rights Reserved.

[www.diodes.com](http://www.diodes.com)