

Description

The AP3118 is a Current Mode PWM controller specially designed for offline power supply that requires ultra-low standby power, high-power density and comprehensive protection. Coordinating with secondary USB PD controller, which can provide a total USB PD solution.

The PWM switching frequency at normal operation is internally fixed (about 65kHz). At middle load, the IC will enter green mode, and the switching frequency will smoothly decrease along with the decreasing load. A minimum switching frequency (about 25kHz) is set to avoid the audible noise. AP3118 supports transient peak power excursion. At peak load, the frequency will be increased from 65kHz to 120kHz to meet the requirement of output power. The duration time is internally set to 30ms. At no load or light load, the IC will enter the burst mode to minimize standby power. Furthermore, the frequency dithering function is built-in to reduce EMI emission in normal and green mode.

The AP3118 provides an inner high-voltage start-up function through HV pin which can reduce the standby loss. The HV pin also realizes X-CAP discharge function. When an X-CAP is connected to a system, it will discharge the X-CAP when the AC line voltage is off automatically without the need for extra discharge resistors.

The AP3118 integrates a VCC LDO circuitry, allowing the LDO to regulate the wide range V_{CC_IN} to an acceptable value. This makes the AP3118 a good choice in wide range output voltage application.

There are also versatile system protections provided by AP3118, such as secondary side OVP, secondary side UVP, constant output current limit, cycle-by-cycle current limit (OCP), brown-out protection, programmable external OTP, etc.

Features

- Current Mode Control
- High-Voltage Startup
- Frequency Fold Back for High Average Efficiency
- 130k Maximum Frequency for Peak Load
- Two Levels Timer Control for OLP and SCP
- Audible Noise Free
- Green-Mode Control
- Embedded VCC LDO to Guarantee Wide Range V_{CC_IN} Voltage
- Constant Output Current in Output Short Situation
- Low VCC Charge Current Reduces Standby Power in Output Short Situation
- Internal Slope Compensation
- Soft Start During Startup Process
- V_{CC} Maintain Mode
- X-CAP Discharge Function
- Precise Secondary Side OVP and UVP
- Programmable External OTP
- Brown-Out Protection
- Overload Protection
- FOCP and SSCP Protection
- Useful Pin Fault Protection
- SSOP-9 (Type CJ) is Available
- **Totally Lead-Free & Fully RoHS Compliant (Notes 1 & 2)**
- **Halogen and Antimony Free. "Green" Device (Note 3)**

- Notes:
1. No purposely added lead. Fully EU Directive 2002/95/EC (RoHS), 2011/65/EU (RoHS 2) & 2015/863/EU (RoHS 3) compliant.
 2. See <https://www.diodes.com/quality/lead-free/> for more information about Diodes Incorporated's definitions of Halogen- and Antimony-free, "Green" and Lead-free.
 3. Halogen- and Antimony-free "Green" products are defined as those which contain <900ppm bromine, <900ppm chlorine (<1500ppm total Br + Cl) and <1000ppm antimony compounds.

Pin Assignments

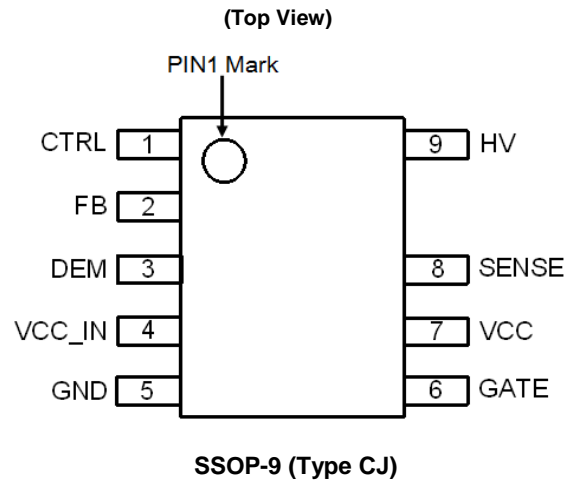

Applications

- Switching AC-DC Adapter/Charger
- Open Frame Switching Power Supply

Typical Applications Circuit

NEW PRODUCT

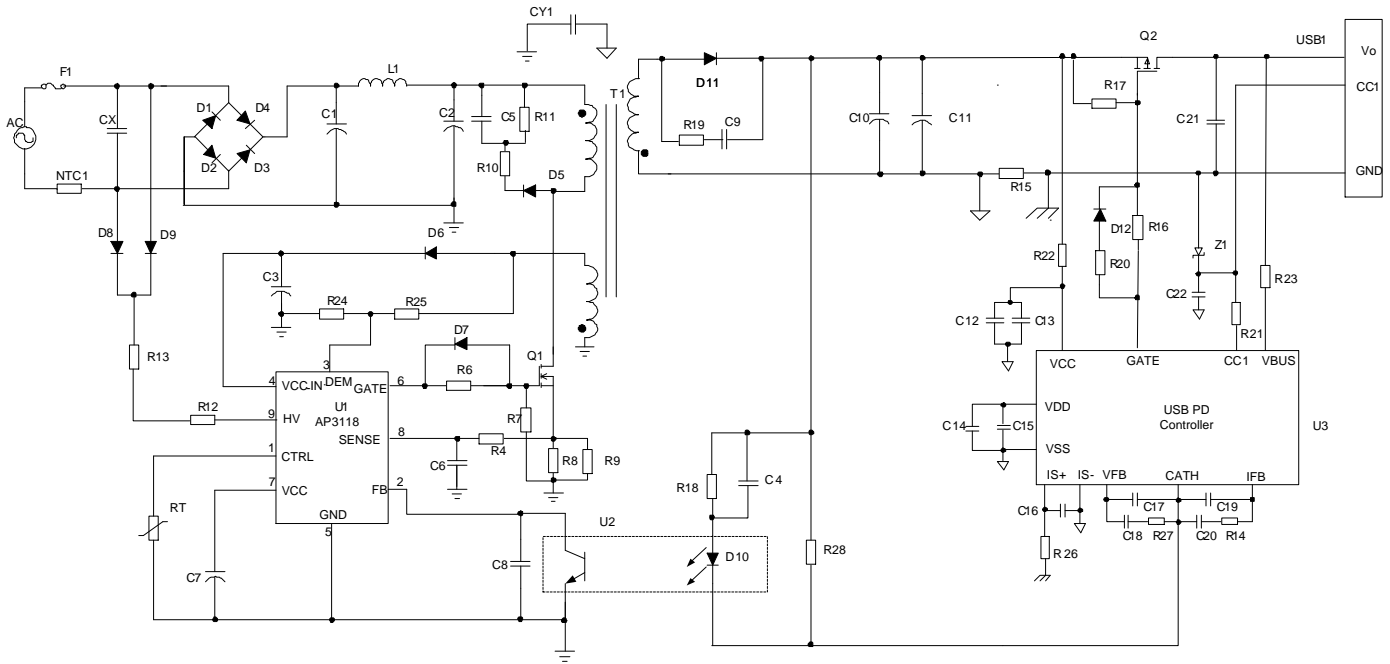

Pin Descriptions

Pin Name	Function	
1	CTRL	Programmable External Protection
2	FB	Feedback. Directly Connected to the Opto-coupler
3	DEM	Sample V_{OUT} to Realize SOVP and SUVP Protection
4	VCC_IN	Wide Range Input Supply Voltage to Produce V_{CC}
5	GND	Signal Ground
6	GATE	Gate Driver Output
7	VCC	Supply Voltage of Driver and Control Circuits
8	SENSE	Sense the Primary Current
9	HV	High Voltage Input. Sense Line Voltage and Provide Startup Current to V_{CC}

Functional Block Diagram

NEW PRODUCT

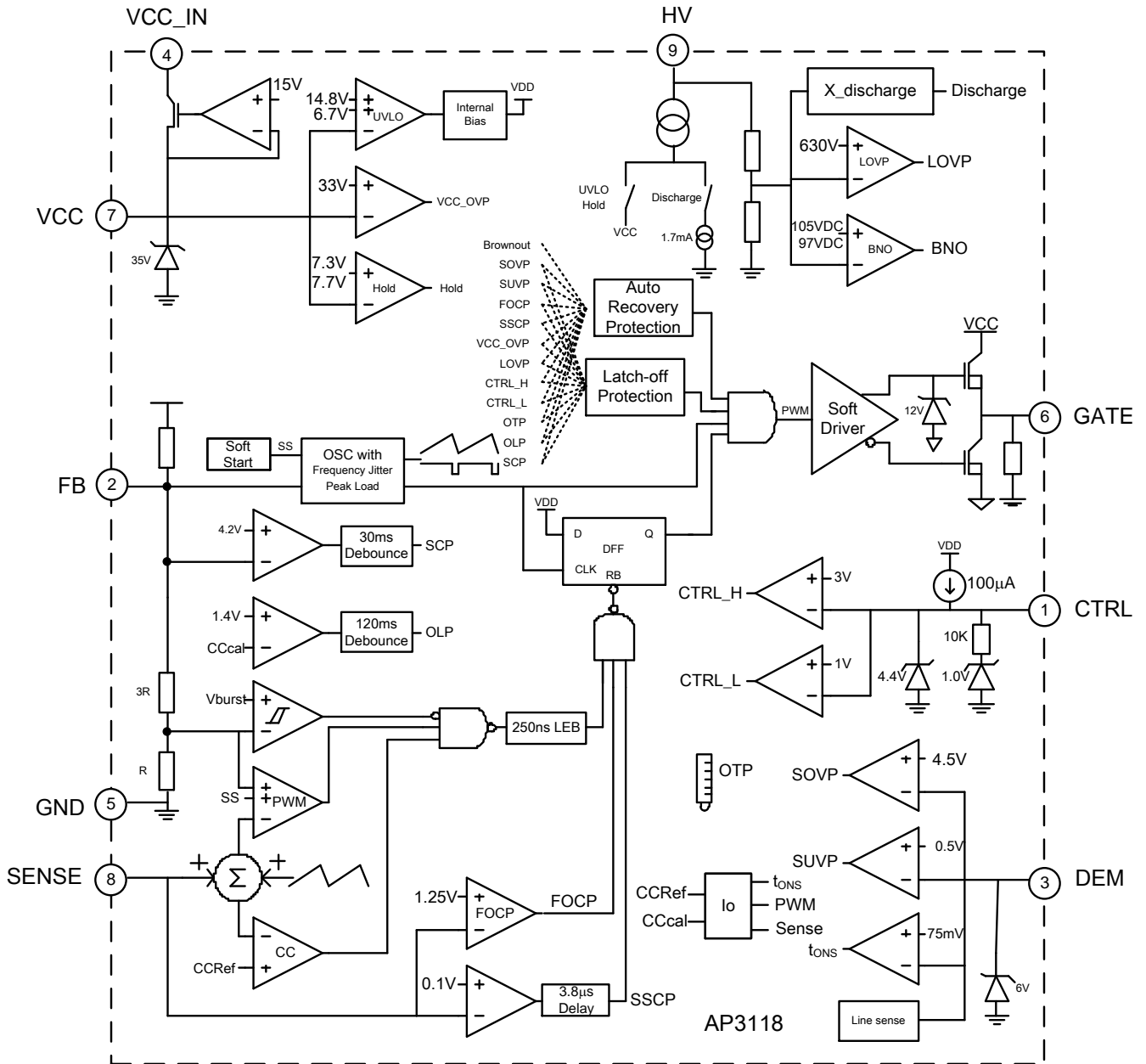

Absolute Maximum Ratings (Note 4)

Symbol	Parameter	Rating	Unit
V_{HV}	HV Pin Input Voltage	700	V
V_{CC_IN}	LDO Supply Voltage	100	V
V_{CC}	Power Supply Voltage	40	V
I_o	Gate Output Current	500	mA
$V_{FB}, V_{SENSE}, V_{CTRL}, V_{DEM}$	Input Voltage to FB, SENSE, CTRL, DEM	-0.3 to 7	V
θ_{JA}	Thermal Resistance (Junction to Ambient)	165	°C/W
P_D	Power Dissipation at $T_A < +25^\circ\text{C}$	550	mW
T_J	Operating Junction Temperature	-40 to +150	°C
T_{STG}	Storage Temperature Range	+150	°C
ESD	Human Body Model (Except HV Pin and V_{CC_IN} Pin (Note 5))	2,000	V
	Machine Model (Except HV Pin and V_{CC_IN} Pin (Note 5))	200	V

Notes: 4. Stresses greater than those listed under "Absolute Maximum Ratings" may cause permanent damage to the device. These are stress ratings only, and functional operation of the device at these or any other conditions beyond those indicated under "Recommended Operating Conditions" is not implied. Exposure to "Absolute Maximum Ratings" for extended periods may affect device reliability.
 5. ESD sensitive pins with HV device.

Recommended Operating Conditions

Symbol	Parameter	Min	Max	Unit
V_{CC_IN}	LDO Supply Input Voltage	10	60	V
V_{CC}	Power Supply Voltage	10	28	V
T_{OP}	Operating Temperature Range	-40	+85	°C

Electrical Characteristics (@T_A = -40 to +85°C, V_{CC} = 16V, unless otherwise specified.)

Symbol	Parameter	Condition	Min	Typ	Max	Unit
Power Supply Voltage (VCC Pin)						
I _{ST}	Startup Current	–	–	1.5	15	μA
I _{CC}	Operating Supply Current	V _{FB} = 0V, V _{CC} = 18V	0.25	0.45	0.65	mA
		V _{FB} = 3V, C _L = 1nF, V _{CC} = 18V	1.5	1.9	2.3	
V _{ST}	Turn-On Threshold Voltage	–	13.8	14.8	15.8	V
V _{CC-UVLO}	VCC UVLO Voltage	–	6.1	6.7	7.1	V
V _{CC-OVP}	VCC OVP Threshold Voltage	–	32	33	34	V
V _{DE-LATCH}	De-Latch VCC Voltage	–	3	4.4	6	V
V _{HOLD-ENTRY}	VCC Hold Entry Point	–	7.1	7.3	7.5	V
V _{HOLD-HYS}	Hysteresis for V _{CC} Hold	–	–	0.4	–	V
HV Section(HV Pin)						
I _{CHARGE-L}	Charge Current	V _{CC} = 0V, V _{HV} = 100V	0.1	0.23	0.35	mA
I _{CHARGE-H}		V _{CC} = 6V, V _{HV} = 100V	1.4	1.8	2.3	mA
I _{CHARGE-FAULT}	Charge Current if Fault Occurs	V _{CC} = 6V, V _{HV} = 100V	60	90	120	μA
V _{BR-IN}	Brown In Voltage	–	100	105	110	V
V _{BR-OUT}	Brown Out Voltage	–	–	97	–	V
t _{BR-IN}	Delay of Brown In (Note 8)	–	–	100	–	μs
t _{BR-OUT}	Delay of Brown Out (Note 8)	–	–	50	–	ms
V _{LOVP}	Line OVP (Note 8)	–	–	630	–	V
I _{DISCH-X}	X-CAP Discharge Current	–	1.3	1.7	2.1	mA
PWM Section/Oscillator Section						
D _{MAX1}	Maximum Duty Cycle	f _{OSC} = 65kHz	70	75	80	%
D _{MAX2}	Maximum Duty Cycle	f _{OSC} = 120kHz	60	65	70	%
f _s	Oscillation Frequency	–	60	65	70	kHz
f _{OSC-GREEN}	Green Mode Frequency	–	20	–	30	kHz
f _{OSC-PEAK}	Peak Load Frequency	–	110	120	130	kHz
δ _{FREQUENCY-TEMP}	Frequency Temperature Stability	-20°C to +125°C	–	–	5	%
δ _{FREQUENCY-VOL}	Frequency Voltage Stability	V _{CC} = 12V to 30V	–	–	3	%
f _{OSC-JITTER}	Frequency Dithering	–	±4	±6	±8	%
t _{DITHER}	Frequency Dithering Period	–	–	4	–	ms
Current Sense Section (SENSE Pin)						
V _{ref_CC}	Reference for Primary Current Control	–	2.45	2.5	2.55	V

Electrical Characteristics (@ $T_A = -40$ to $+85^\circ\text{C}$, $V_{CC} = 16\text{V}$, unless otherwise specified.) (Cont.)

Symbol	Parameter	Condition	Min	Typ	Max	Unit
$t_{\text{DELAY-CS}}$	Delay to Output (Note 6)	–	–	100	–	ns
$V_{\text{TH-FOCP}}$	FOCP Voltage	–	–	1.25	–	V
$V_{\text{TH-SSCP}}$	SSCP Voltage	–	80	100	120	mV
t_{LEB}	LEB Time of SENSE	–	200	250	300	ns
$t_{\text{SOFT-ST}}$	Soft-Start Time	–	3	4	8	ms
Feedback Input Section (FB Pin)						
$K_{\text{FB-CS}}$	The Ratio of FB Input Voltage	–	3.5	4	4.5	V/V
R_{FB}	Input Impedance	–	19	25	31	k Ω
$I_{\text{FB-SOURCE}}$	Source Current	$V_{\text{FB}} = 0\text{V}$	0.1	0.2	0.3	mA
$V_{\text{FB-PEAK-START}}$	Start of Peak Frequency Rising	–	–	3.1	–	V
$V_{\text{FB-PEAK-END}}$	End of Peak Frequency Rising	–	–	3.5	–	V
$V_{\text{FB-FOLD-START}}$	Start of Frequency Foldback	–	–	1.7	–	V
$V_{\text{FB-FOLD-END}}$	End of Frequency Foldback	–	–	1.3	–	V
V_{BURST}	Input Voltage for Zero Duty	$V_{\text{DEM}} > 2\text{V}$	0.5	0.66	0.8	V
		$V_{\text{DEM}} < 2\text{V}$	0.3	0.46	0.6	V
$V_{\text{BURST-HYS}}$	Hysteresis for Burst Mode	–	–	130	–	mV
$t_{\text{DEB-OLP}}$	OLP Debounce Time	–	–	120	–	ms
$V_{\text{FB-SC}}$	Feedback Voltage when SCP is Activated	–	–	4.2	–	V
$t_{\text{DEB-SCP}}$	SCP Debounce Time	–	–	30	–	ms
Output Section (GATE Pin)						
$V_{\text{GATE-L}}$	Output Low-Level Voltage	$I_O = 20\text{mA}$, $V_{CC} = 12\text{V}$	–	–	1	V
$V_{\text{GATE-H1}}$	Output High-Level Voltage	$I_O = 20\text{mA}$, $V_{CC} = 12\text{V}$	8	–	–	V
$V_{\text{GATE-H2}}$	Output High-Level Voltage	$I_O = 15\text{mA}$, $V_{CC} = 7\text{V}$	6	6.4	7	V
$V_{\text{GATE-CLP}}$	Output Clamping Voltage	$V_{CC} = 20\text{V}$	9.5	10.5	11	V
$t_{\text{GATE-RISE}}$	Rising Time	$C_L = 1\text{nF}$, $V_{CC} = 13\text{V}$	–	150	300	ns
$t_{\text{GATE-FALL}}$	Falling Time	$C_L = 1\text{nF}$, $V_{CC} = 13\text{V}$	–	50	100	ns
De-magnetization Section (DEM Pin)						
$V_{\text{TH-DEM}}$	De-Magnetization	–	–	75	–	mV
$V_{\text{CLP-L}}$	Clamping Voltage	$I_{\text{DEM}} = -200\mu\text{A}$	-50	-5	–	mV
$V_{\text{CLP-H}}$		$I_{\text{DEM}} = 1\text{mA}$	5	5.8	6.5	V
$V_{\text{TH-SOVP-L}}$	SOVP Threshold for Startup	–	1.05	1.1	1.15	V
$V_{\text{TH-SOVP-H}}$	SOVP Threshold for Steady	–	4.3	4.5	4.7	V
$t_{\text{DEB-SOVP}}$	SOVP Debounce Time	–	–	7	–	Cycle
$V_{\text{TH-SUVP-L}}$	SUVP Threshold for Hiccup	–	0.48	0.5	0.52	V
$t_{\text{DEB-SUVP}}$	SUVP Debounce Time	–	–	7	–	Cycle

Note: 6. Cycle-by-Cycle limit delay time contains OCP comparator delay time and driver delay time, Guaranteed by design.

Electrical Characteristics (@T_A = -40 to +85°C, V_{CC} = 16V, unless otherwise specified.) (Cont.)

Symbol	Parameter	Condition	Min	Typ	Max	Unit
t _{BLANK-SUVP}	SUVP Blank Time after Startup	–	22	27	32	ms
t _{SAMPLE}	Sample Delay Time (Note 8)	–	–	2	–	µs
LDO Section (V_{CC_IN} Pin/V_{CC} Pin)						
V _{CC}	LDO Regulated Voltage (Power Supply Voltage)	V _{CC} open, V _{CC_IN} =10V	9.4	9.8	9.9	V
		V _{CC} open, V _{CC_IN} =40V	14	15	16	V
I _{LDO}	Operating Current	V _{CC} =12V, V _{CC_IN} =40V	-10	-8.5	-7	mA
Protection Section (CTRL Pin)						
I _{CTRL-SOURCE}	Source Current	–	-110	-100	-90	µA
V _{TH-CTRL-L}	Low Threshold	–	0.96	1	1.04	V
t _{CTRL-BLANK}	Blank Time when V _{CTRL} is Low	–	–	30	–	ms
V _{TH-CTRL-H}	High Threshold	–	2.85	3	3.15	V
V _{CTRL-CLP}	Clamp Voltage (Note 7)	I _{CTRL} = -2mA	4.0	4.4	4.8	V
t _{DELAY-HICC}	Delay of Hiccup Protection (Note 8)	SUVP, SOVP, Line OVP, VCC OVP,FOCP,SSCP, CTRL Pin Protection	–	7	–	Cycles
Internal OTP Section						
OTP	OTP Threshold	–	–	+150	–	°C
T _{HYS}	OTP Recovery Hysteresis	–	–	+25	–	°C
t _{DEB-OTP}	OTP Debounce Time	–	–	7	–	Cycle

Notes: 7. The sourcing current of CTRL pin must be limited below 5mA. Otherwise it may cause permanent damage to the device.
8. Guaranteed by design.

Performance Characteristics

NEW PRODUCT

Startup Voltage vs. Ambient Temperature

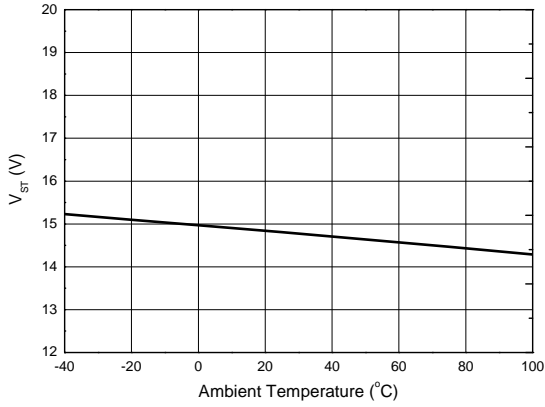

Shutdown Voltage vs. Ambient Temperature

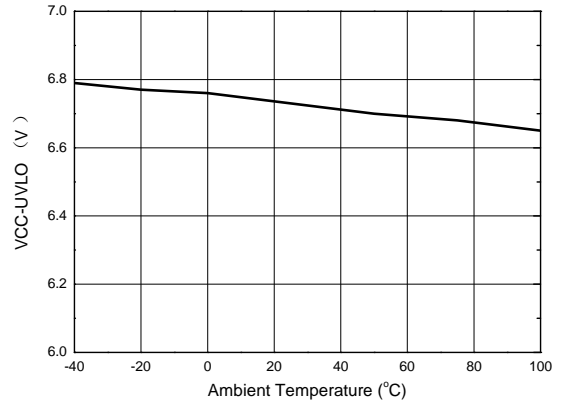

Oscillation frequency vs. Ambient Temperature

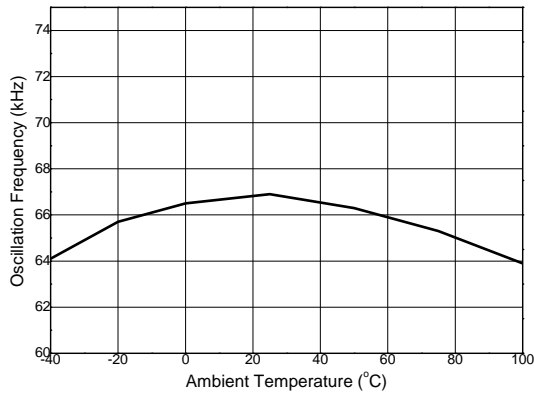

FB Pin Input Impedance vs. Ambient Temperature

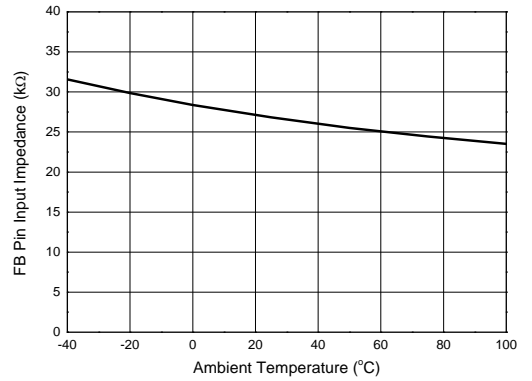

I_{LDO} vs. Ambient Temperature

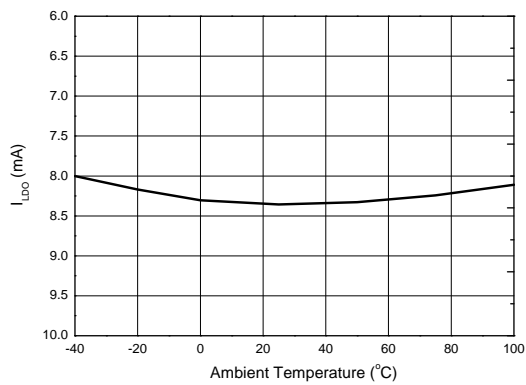

V_{BR-IN} vs. Ambient Temperature

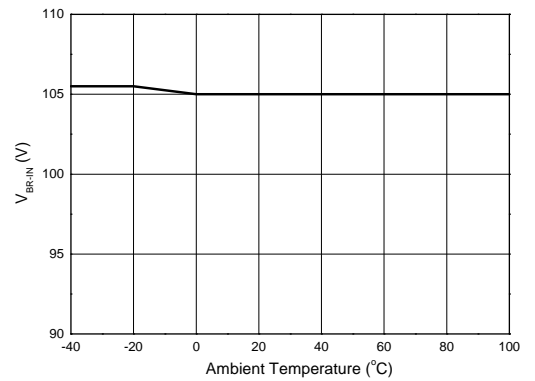

Performance Characteristics (Cont.)

V_{BR-OUT} vs. Ambient Temperature

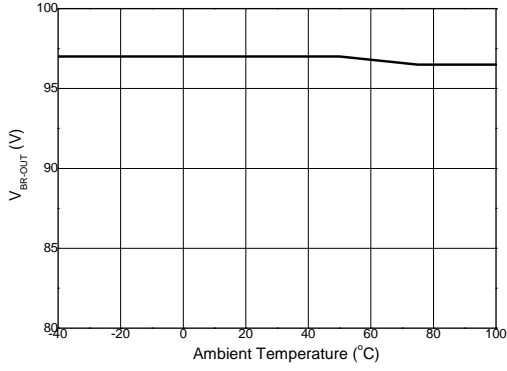

$V_{TH-SOVP-H}$ vs. Ambient Temperature

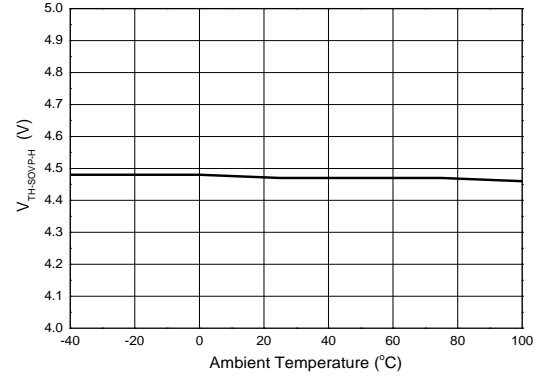

$V_{TH-SUVP-L}$ vs. Ambient Temperature

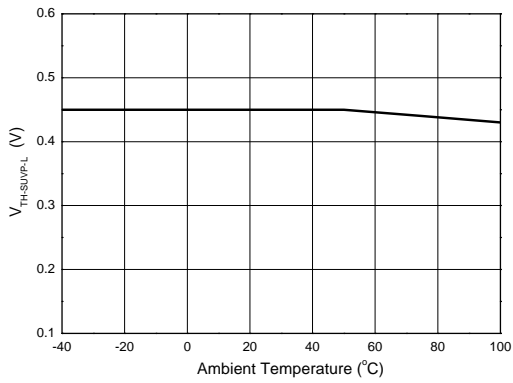

Operation Description

PWM Operation Principle

The secondary inner CV and CC amplifier combine with an external compensation network to generate an amplified error signal and transfer to the primary side FB pin through the opto-coupler. The scaled FB voltage comparing with the SENSE voltage after slope compensation will turn off primary switch and determine the duty cycle.

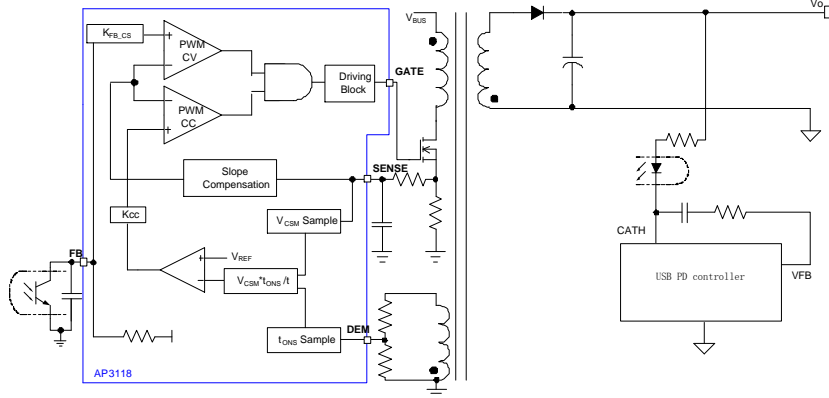

Figure 1

Switching Frequency Control Strategy

The AP3118 works in fixed frequency (65kHz) under heavy load, and decreases the switching frequency to improve the efficiency at light load through green mode control. Under peak load mode, the switching frequency increases to deliver more energy to output, and the maximum frequency is set to 130kHz. The switching frequency is a function of V_{FB}, which the relationship is shown as Figure 2. If the V_{FB} is lower than V_{TH-GREEN}-1.3V, the switching frequency is fixed at 25kHz to avoid audible noise.

Burst mode is a traditional method used to reduce the standby power at no load and extremely light load. This is accomplished by monitoring FB pin voltage. As shown in Figure 3, when V_{FB} drops below V_{BURST} because of the light load, the system will enter burst mode and there is no more power transferred to the output, output voltage decreases and V_{FB} recovers to V_{BURST} +130mV, the system sends switching pulses. Then the output voltage rises and V_{FB} drops again. When V_{FB} drops to burst threshold level, the system stops outputting switching pulses, which will start a new cycle.

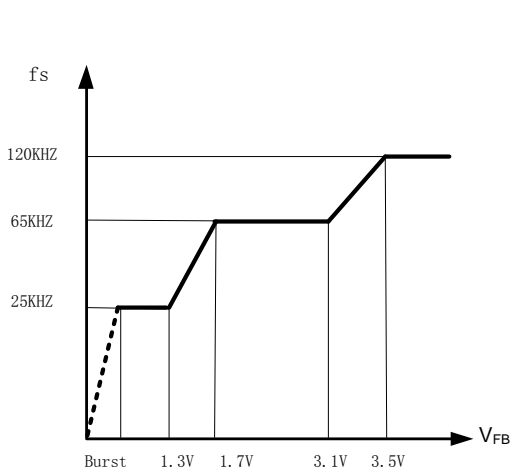

Figure 2

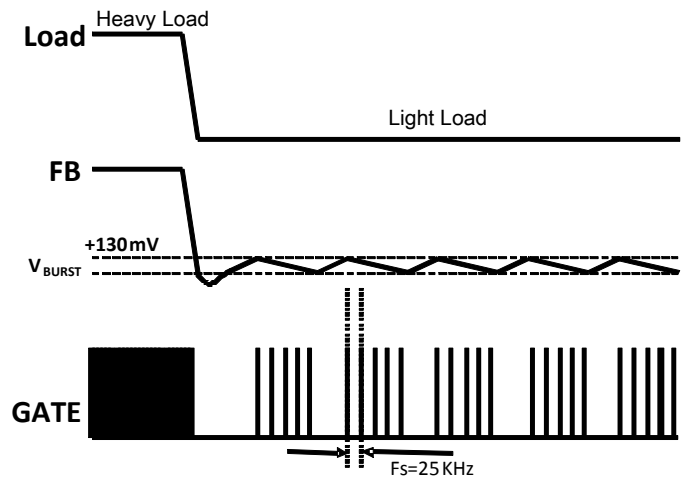

Figure 3

Maximum Output Current Limit

The traditional primary cycle-by-cycle peak current limit method works well for overload protection situation, but the output short current (peak value) is still too high, which will result in a higher safety risk. In order to reduce output short current (peak value) and keep normal startup performance, the AP3118 creates a new primary current control method to get a constant output current limit. The output current both for CCM and DCM can be described as:

$$I_o = \frac{V_{CSM}}{R_{CS}} * \frac{N_p}{N_s} * \frac{t_{ONS}}{t}$$

Operation Principle Description (Cont.)

Where R_{CS} is the primary current sense resistor, V_{CSM} is the middle voltage of the current sense voltage across R_{CS} , N_P is the primary winding turns, N_S is the secondary winding turns, t_{ONS} is the conduction time of secondary rectifier, t is the switching period of the system. To get a constant output current, the product of V_{CSM} and $\frac{t_{ONS}}{t}$ is kept as a constant value equaling to V_{REF} , so the output current equation can be rearranged as:

$$I_O = \frac{V_{REF}}{R_{CS}} * \frac{N_P}{N_S} * K_{CC}$$

Where K_{CC} is 1/8, an inner parameter used to balance the relationship between the current sense voltage and output current.

The AP3118 samples the middle current of the primary side to calculate the output current. The detecting time takes the GATE signal as the reference shown as Figure 4, at the half-on time of the GATE, the AP3118 will record the V_{CS} value as V_{CSM} . In the actual system, the primary current will be greatly impacted by the turn-off delay time which mainly contains MOSFET charging time, resulting in an error between the detected V_{CSM} and the actual V_{CSM} . The error varies depending on line voltage, generally increasing with the line voltage. To get a precise V_{CSM} and keep the output current constant, the AP3118 adopts a line compensation technology and the control block is illustrated in Figure 5. The current flowing through R1 when the primary MOSFET is on. Scale down the current and multiply it with R_C and R_F , then a compensation signal is formed. The external resistor R1 can be used to adjust the compensation according to different delay time. The calculating formula is:

$$R1 = \frac{2 * L_P}{t_D} * \frac{N_A}{N_P} * \frac{(R_C + R_F)}{R_{CS}} * \frac{1}{m}$$

Where L_P is the inductance of the transformer, t_D is the turn-off delay time, N_A is the auxiliary winding turns, N_P is the primary winding turns, R_C is the inner compensation resistor which is 5kΩ, R_F is the filter resistor of SENSE pin, R_{CS} is the primary-current sense resistor, m is the inner proportional parameter which is 21.

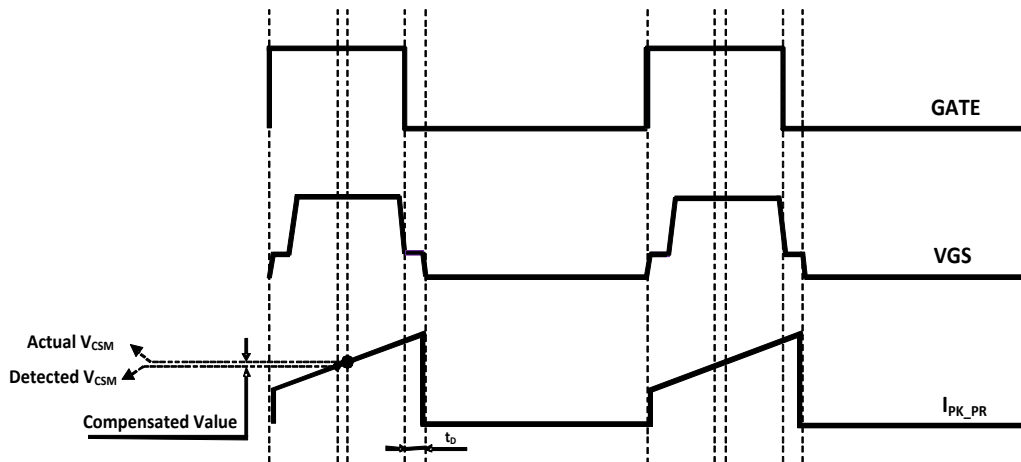

Figure 4

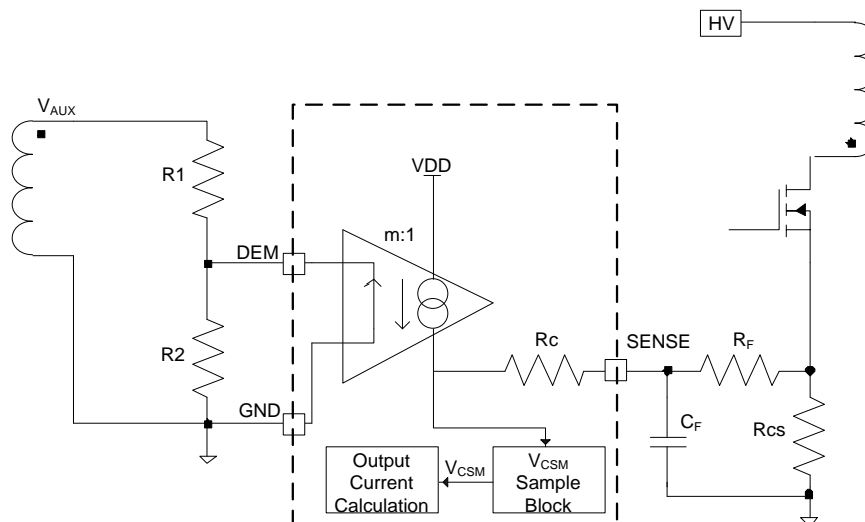

Figure 5

Operation Principle Description (Cont.)

HV Start-Up Circuit

A built-in HV Start-Up circuit in AP3118 can help to simplify the power system design for ultra low standby application. For AP3118, there are two HV Start-Up charging current: the $I_{CHARGE-L}$ when V_{CC} is lower than 3V and the $I_{CHARGE-H}$ when the V_{CC} voltage rises above 3V, which can prevent the IC from overheat when V_{CC} short- to-GND fault happens. The HV Start-Up circuit will stop working and has no additional power dissipation when V_{CC} voltage reaches the V_{ST} , at which the AP3118 starts working and will supply energy to V_{CC} from auxiliary winding.

However, the charging process described above is only for the normal system startup condition. Once some system faults occur and the protection process is triggered, AP3118 will shut down and V_{CC} voltage will begin to decrease. The HV Start-Up circuit starts working again when V_{CC} voltage decreases below $V_{CC-UVLO}$, and charges the V_{CC} capacitor with current of $I_{CHARGE-FAULT}$. This special design can reduce hugely the input power dissipation when system fault happens, especially for output short condition. The HV Start-Up circuit working processes is illustrated in Figure 6.

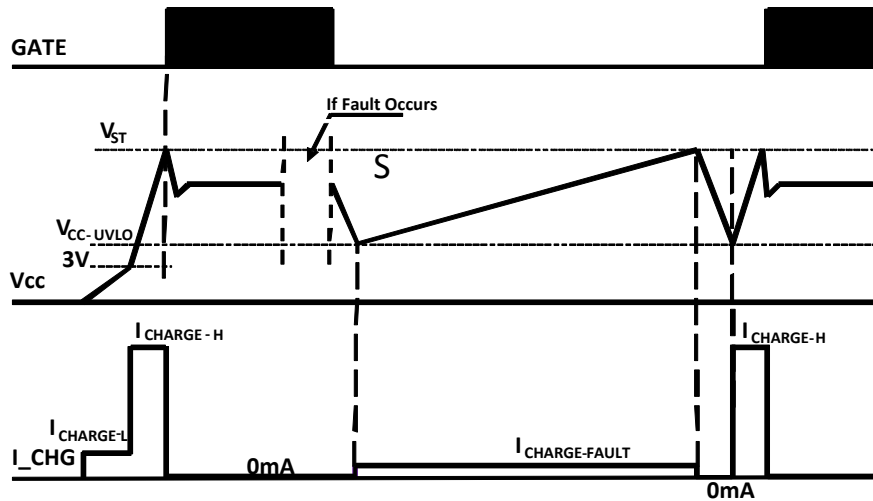

Figure 6

X-CAP Discharge Function

For the higher power application, to attenuate the differential mode noise, an X-CAP is usually used before the rectifier bridge, and there are paralleled resistors to discharge the X-CAP for safety consideration when the AC line is off. The paralleled resistors have large power dissipation and will increase the standby power. The AP3118 integrates an X-CAP discharge function to replace discharge resistors and decreases the standby power.

This function contains two processes; the first process detects the condition of the AC line through HV Pin, this detected voltage is named as V_b . When the system is plugged in, an inner timer of 40ms within the AP3118 begins to work, meanwhile, a phase-drifted and filtered signal V_c is generated based on V_b , compare V_b with V_c , as shown in Figure 7.

Whenever signal V_c crosses over with signal V_b , the inner 40ms timer will be reset which represents the AC line is on. If the system is disconnected from AC line, the cross-over signal of V_c and V_b will disappear and the 40ms timer will continue to count until it reaches 40ms, at this moment, the discharge process will come into effect and a 1.7mA discharge current will flow through HV pin to GND lasting for 40ms. After the AC line is off, the first process and the second process will act alternately until the HV Pin voltage is discharged below 10V even when the V_{CC} voltage is lower than $V_{CC-UVLO}$.

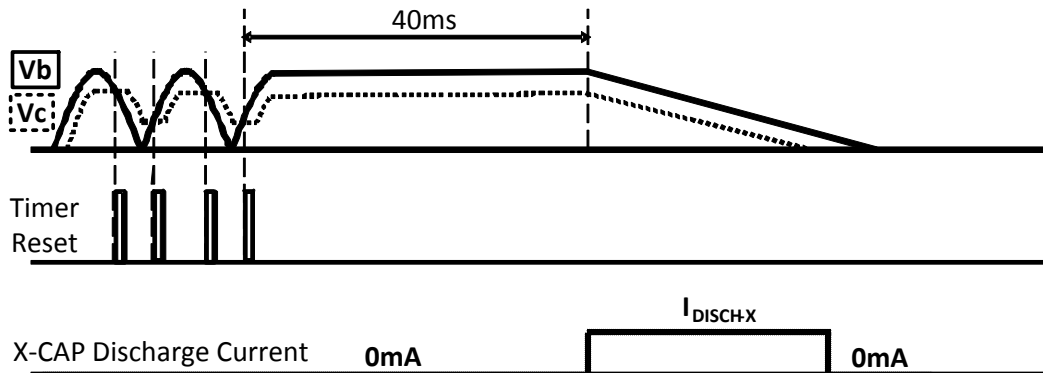

Figure 7

Operation Principle Description (Cont.)

Built-In Slope Compensation

It is well known that a continuous current mode SMPS may become unstable when the duty cycle exceeds 50%. The built-in slope compensation in the AP3118 can keep the system stable.

Built-In V_{CC} LDO

The AP3118 integrates a V_{CC} LDO circuitry, the LDO regulates the wide range V_{CC_IN} which is rectified from auxiliary winding to an acceptable value. It makes the AP3118 a good choice in wide range output voltage application.

Brown In/Out Protection

To avoid potential high-current stress at low line voltage, the AP3118 introduces a reliable brownout protection. The AC line voltage is detected through HV Pin, A pair of high-voltage diodes are connected to the AC line which will rectify the AC input voltage to a double-frequency positive voltage referring to GND, a 20k Ω resistor is recommended to be added to improve the surge immunity. When the voltage across HV pin is higher than V_{BR_IN} for about 100 μ s of t_{BR_IN} and V_{CC} reaches V_{ST} , the GATE pin will output drive signals and the system starts to work. If the HV pin voltage falls below V_{BR_OUT} and lasts for 50ms of t_{BR_OUT} , the GATE pin will turn off and the system will shut down until the line voltage rises over its brown-in voltage again.

SOVP/SUVP Protection

The AP3118 provides output OVP and UVP protection function. The auxiliary winding voltage during secondary rectifier conducting period reflects the output voltage. A voltage divide network is connected to the auxiliary winding and DEM Pin, the DEM Pin will detect the equivalent output voltage with a delay of t_{SAMPLE} from the falling edge of GATE driver signal, as shown in Figure 8. The detected voltage will be compared to the SOVP and SUVP threshold voltage V_{TH_SOVP} and V_{TH_SUVP} . If the SOVP or SUVP threshold is reached continuously by 7 switching cycles, the SOVP or SUVP protection will be triggered, the AP3118 will shut down and the system will restart when the V_{CC} voltage falls below the UVLO voltage.

To prevent from false-trigger of SUVP during start up process, a blank time of t_{BLANK_SUVP} is set during which the SUVP protection function is ignored.

Two levels of OCP Control

The AP3118 sets two levels OCP protection thresholds to distinguish overload protection and short circuit protection. When overload condition occurs ($8 * V_{CSM} * \frac{I_{ONS}}{I} > 1.4V$), the internal timer begins to operate. After 120ms, IC enters into protection status. For short circuit protection ($FB > 4.2V$), the internal timer is set to 30ms.

Externally Triggered Protection

The AP3118 reserves flexible protection mode for power design. The CTRL Pin can achieve external programmable protection. A high threshold of $V_{TH_CTRL_H}$ is set for any over voltage protection, if the CTRL Pin voltage is higher than the threshold for 7 switching cycles, the CTRL-High protection will be triggered. A low threshold of $V_{TH_CTRL_L}$ is usually used for external over temperature protection. To realize the external OTP, a proper value NTC should be connected from the CTRL Pin to the ground. An inner current of 100 μ A flows through the NTC from the CTRL pin. If the CTRL Pin voltage is lower than the $V_{TH_CTRL_L}$ for 32ms duration at least, the CTRL-Low protection will be triggered. Whenever the protection is triggered, the system will stop the output drive signal and will restart after the V_{CC} voltage falling below the UVLO voltage.

System Protection

LOVP, FOCP, SSCP, VCC OVP, OTP

The AP3118 provides versatile protection to ensure the reliability of the power system. LOVP achieves line voltage overvoltage protection, if the detected AC line voltage is higher than V_{LOVP} for 7 switching cycles, the LOVP protection will be triggered. FOCP protection is an ultra-fast short-current protection which is helpful to avoid catastrophic damage of the system when the secondary rectifier is short. The primary peak current will be monitored by SENSE pin through a primary sense resistor, whenever the sampled voltage reaches the threshold of V_{TH_FOCP} for 7 switching cycles continuously, the FOCP protection will be active to shut down the switching pulse. SSCP might be triggered at ultra-low line voltage condition or other failure condition that short the SENSE pin to ground. The SSCP module senses the voltage across the primary sense resistor with a delay of 4 μ s after the rising edge of primary GATE signal, this sensed signal is compared with V_{TH_SSCP} . If it is lower than V_{TH_SSCP} for 7 switching cycles, the SSCP protection will be triggered and the drive signal will be disabled. All these protections described above will restart the system when the V_{CC} voltage falls below UVLO. Although the external OTP can be easily implemented through CTRL pin, the AP3118 still reserves the inner OTP with a hysteresis for any necessary use.

Operation Principle Description (Cont.)

V_{CC} Maintain Mode

During light-load or transient-load condition, V_{FB} will drop and be lower than V_{BURST}, thus the PWM drive signal will be stopped, and there is no energy transferring to the output. Therefore, the IC V_{CC} supply voltage may decrease to the UVLO threshold voltage and system may enter the unexpected restart mode. To avoid this, the AP3118 holds a so-called V_{CC} maintain mode which can supply energy to V_{CC}.

When V_{CC} decreases to a setting threshold as V_{HOLD-ENTRY}, the V_{CC} maintain mode will be awaked and a charging current of I_{CHARGE-H} will flow to the V_{CC} Pin. With V_{CC} maintain mode, the V_{CC} is not easy to touch the shutdown threshold during the startup process and transient load condition. This will also simplify the system design. The minimum V_{CC} voltage is suggested to be designed a little higher than V_{CC} maintain threshold thus can achieve the best balance between the power loss and step load performance.

Leading-Edge Blanking Time

A narrow spike on the leading edge of the current waveform can usually be observed when the power MOSFET is turned on. A 250ns leading-edge blank is built-in to prevent the false-trigger caused by the turn-on spike. During this period, the current limit comparator and the PWM comparator are disabled and the gate driver cannot be switched off.

At the time of turning-off the MOSFET, a negative undershoot (maybe larger than -0.3V) can occur on the SENSE pin. So it is strongly recommended to add a small RC filter or at least connect a resistor "R" on this pin to protect the IC (Shown as Figure 8).

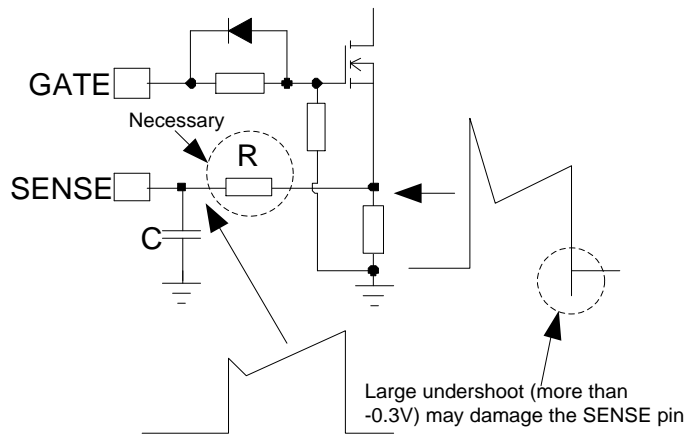
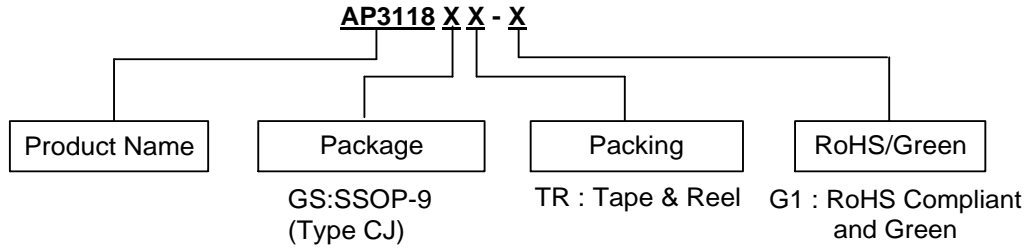

Figure 8

Ordering Information



Package	Temperature Range	Part Number	Marking ID	Packing
SSOP-9 (Type CJ)	-40°C to +85°C	AP3118GSTR-G1	3118GS-G1	4,000/Tape & Reel

Marking Information

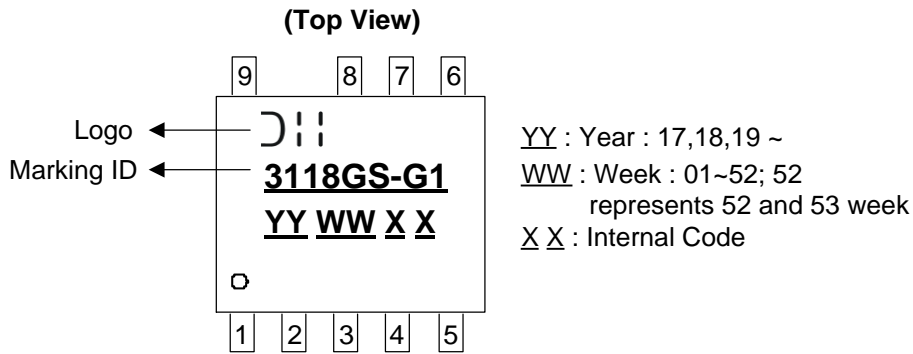

Package Outline Dimensions (All dimensions in mm.)

Please see <http://www.diodes.com/package-outlines.html> for the latest version.

(1) Package Type: SSOP-9 (Type CJ)

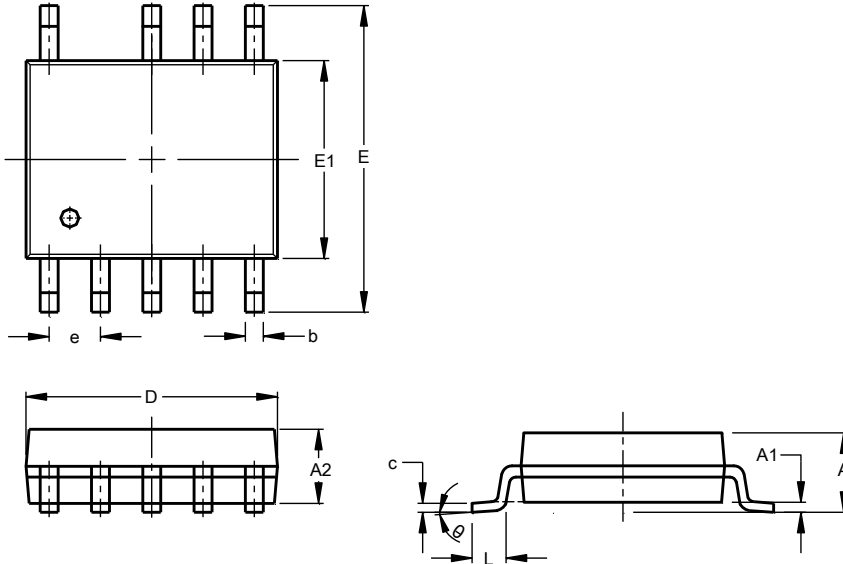

SSOP-9 (Type CJ)			
Dim	Min	Max	Typ
A	1.35	1.75	--
A1	0.10	0.25	--
A2	1.350	1.550	--
b	0.270	0.430	--
c	0.170	0.258	--
D	4.70	5.10	--
E	5.80	6.20	--
E1	3.80	4.00	--
e	--	--	1.00
L	0.40	1.27	--
θ	0°	8°	--
All Dimensions in mm			

Suggested Pad Layout

Please see <http://www.diodes.com/package-outlines.html> for the latest version.

(1) Package Type: SSOP-9 (Type CJ)

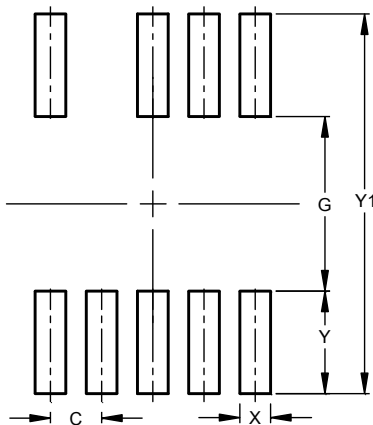

Dimensions	Value (in mm)
C	1.00
G	3.40
X	0.60
Y	2.00
Y1	7.40

NEW PRODUCT

IMPORTANT NOTICE

DIODES INCORPORATED MAKES NO WARRANTY OF ANY KIND, EXPRESS OR IMPLIED, WITH REGARDS TO THIS DOCUMENT, INCLUDING, BUT NOT LIMITED TO, THE IMPLIED WARRANTIES OF MERCHANTABILITY AND FITNESS FOR A PARTICULAR PURPOSE (AND THEIR EQUIVALENTS UNDER THE LAWS OF ANY JURISDICTION).

Diodes Incorporated and its subsidiaries reserve the right to make modifications, enhancements, improvements, corrections or other changes without further notice to this document and any product described herein. Diodes Incorporated does not assume any liability arising out of the application or use of this document or any product described herein; neither does Diodes Incorporated convey any license under its patent or trademark rights, nor the rights of others. Any Customer or user of this document or products described herein in such applications shall assume all risks of such use and will agree to hold Diodes Incorporated and all the companies whose products are represented on Diodes Incorporated website, harmless against all damages.

Diodes Incorporated does not warrant or accept any liability whatsoever in respect of any products purchased through unauthorized sales channel. Should Customers purchase or use Diodes Incorporated products for any unintended or unauthorized application, Customers shall indemnify and hold Diodes Incorporated and its representatives harmless against all claims, damages, expenses, and attorney fees arising out of, directly or indirectly, any claim of personal injury or death associated with such unintended or unauthorized application.

Products described herein may be covered by one or more United States, international or foreign patents pending. Product names and markings noted herein may also be covered by one or more United States, international or foreign trademarks.

This document is written in English but may be translated into multiple languages for reference. Only the English version of this document is the final and determinative format released by Diodes Incorporated.

LIFE SUPPORT

Diodes Incorporated products are specifically not authorized for use as critical components in life support devices or systems without the express written approval of the Chief Executive Officer of Diodes Incorporated. As used herein:

A. Life support devices or systems are devices or systems which:

1. are intended to implant into the body, or
2. support or sustain life and whose failure to perform when properly used in accordance with instructions for use provided in the labeling can be reasonably expected to result in significant injury to the user.

B. A critical component is any component in a life support device or system whose failure to perform can be reasonably expected to cause the failure of the life support device or to affect its safety or effectiveness.

Customers represent that they have all necessary expertise in the safety and regulatory ramifications of their life support devices or systems, and acknowledge and agree that they are solely responsible for all legal, regulatory and safety-related requirements concerning their products and any use of Diodes Incorporated products in such safety-critical, life support devices or systems, notwithstanding any devices- or systems-related information or support that may be provided by Diodes Incorporated. Further, Customers must fully indemnify Diodes Incorporated and its representatives against any damages arising out of the use of Diodes Incorporated products in such safety-critical, life support devices or systems.

Copyright © 2018, Diodes Incorporated

www.diodes.com