



# High Voltage Green Mode PWM Controller AP3105

Prepared by Wu Qikun  
System Engineering Dept.

## 1. Introduction

The AP3105 is a low start-up current, current mode PWM controller with green-mode power-saving operation. Different from AP3103, AP3105 PWM switching frequency at normal operation is fixed at 65kHz dithering with a narrow range. The difference between AP3103/AP3105 is shown in Table 1. The dithering of frequency will improve EMI feature. When the load decreases, the frequency will reduce and when at a very low load, the IC will enter the “burst mode” to minimize switching loss. A minimum 20kHz frequency switching is to avoid the audible noise as well as reducing the standby loss. A so-called VCC Maintain Mode is applied under light load to realize a stable output and to reduce the loss on the start-up resistor. The standby power of the system using AP3105 can be reduced to 60mW at 230V input.

	AP3103	AP3105
<b>Frequency</b>	Adjustable	Fixed at 65kHz
<b>VFB Resistor</b>	4.5kΩ	10kΩ
<b>Standby Performance</b>	Better	Best
<b>External Protection</b>	NA	By “CTRL” pin
<b>VCC OVP</b>	Auto-recoverable	Latch /Auto-recoverable
<b>OLP &amp; FOCP</b>	Auto-recoverable	Latch /Auto-recoverable

Table 1. The Difference between AP3103/AP3105

The AP3105 integrates a lot of functions such as the Lead Edge Blanking (LEB) of the current sensing, internal slope compensation and several protection features which include cycle-by-cycle current limit (OCP), fast OCP (FOCP), VCC over voltage protection, OTP, OLP protection. The “CTRL” pin is designed for customers to add external protection functions such as OVP and OTP.

The AP3105 is specially designed for off-line AC-DC power supply, such as LCD monitors, notebook adapter and battery charger applications. It can offer the designers a cost effective solution while keeping versatile protection features. The IC uses SOT-23-6 package type to realize its compact size. This application note includes detailed explanation of the IC’s major functions, some considerations about

the PCB layout, and methods for reducing the standby power loss, and finally presents a demo design of a 12V 1A adaptor.

## 2. Function Description

### 2.1 CTRL Pin

For some applications, the system requires external programmable protection function. The CTRL pin has two kinds of modes to trigger the protection: high level trigger and low level trigger. The low threshold voltage is 0.5V and high threshold is 2.5V. When the CTRL pin voltage is lower than 0.5V or higher than 2.5V, latch or auto-restart protection will be triggered (different versions of 3105 offer different protection combination, which is shown in Table 2).

Version	VCC OVP	OLP& FOCP	CTRL(low)	CTRL(high)
AP3105	Auto-recoverable	Auto-recoverable	Latch	Auto-recoverable
AP3105V	Latch	Auto-recoverable	Latch	Latch
AP3105L	Latch	Latch	Latch	Latch
AP3105R	Auto-recoverable	Auto-recoverable	Auto-recoverable	Latch

Table 2. Version Classification of AP3105

CTRL pin voltage maintains 1.6V if the pin is floating, so leave CTRL pin open if the designer does not need this function. Once the latch protection is triggered, the bulk capacitor will provide the energy to the IC through start-up resistor to ensure the IC disable the output signal (latch mode). This mode will not be released until the AC input is shut off. Therefore, the de-latch time is mainly depending on the value of HV startup bulk capacitor. If the system needs a short de-latch time, it is better for the startup resistor to take power from the point before the rectifier bridge. Typical application of CTRL pin is shown in Figure 1.

Note:

1. The sink current to the CTRL pin should be lower than 5mA by selecting a proper pull up resistor.
2. If the designer needs to apply a bypass capacitor on CTRL pin, the capacitor should not be more than 1nF.

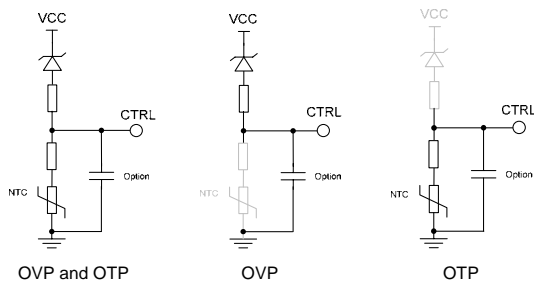

Figure 1. CTRL Pin Application

## 2.2 Fast OCP Function

When the load is short-circuited, the power converter can be protected by OLP protection. But if the output filter inductor and the secondary Schottky is short-circuited, the transformer will be immediately saturated resulting in the breakdown of the MOSFET due to high voltage stress. The AP3105 bears built-in fast OCP function to alleviate the saturation of the transformer and reduce the voltage stress of MOSFET. The FOCP position and FOCP waveform are shown in Figure 2 and Figure 3. When the secondary Schottky and the output filter inductor is short-circuited, the power converter can trigger latch or auto-restart immediately within several switching cycles with fast OCP. The FOCP threshold on FB pin is 1.8V.

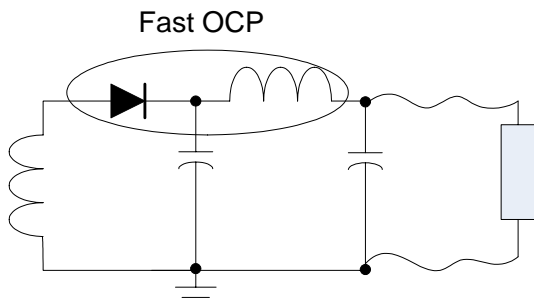

Figure 2. FOCP Position

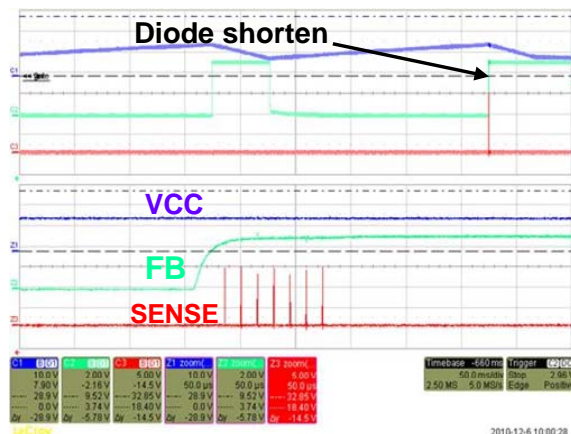

Figure 3. FOCP Waveform

## 2.3 VCC Maintain Mode

Under ultra light load or load transient condition,  $V_{FB}$  will drop to lower than 1.4V, thus the PWM drive signal will be stopped, and there is no more new energy transferred due to no switching. Therefore, the IC supply voltage may drop to the UVLO (off) threshold and the system may enter the unexpected restart mode. To avoid this situation, the AP3105 holds a so-called VCC maintain mode which can supply energy to VCC. When VCC decreases to a setting threshold (10.1V), the VCC maintain comparator will output a drive signal to make the system switch and provide a proper energy to VCC pin. When VCC increases to 10.6V, the gate signal will be stopped. The VCC maintain function will cooperate with the PWM and the burst mode loop to make the output voltage variation be within the regulation. This mode is designed for reducing startup resistor loss and it will achieve a better standby performance with low value VCC capacitor and larger startup resistor. The VCC will not reduce to the UVLO (off) threshold during the startup process and under ultra light load or load transient condition. To avoid the “VCC maintain mode” triggering in normal operating condition, it is suggested to design the VCC value higher than VCC maintain threshold under minimum load condition. The processing of VCC maintain mode is shown in Figure 4.

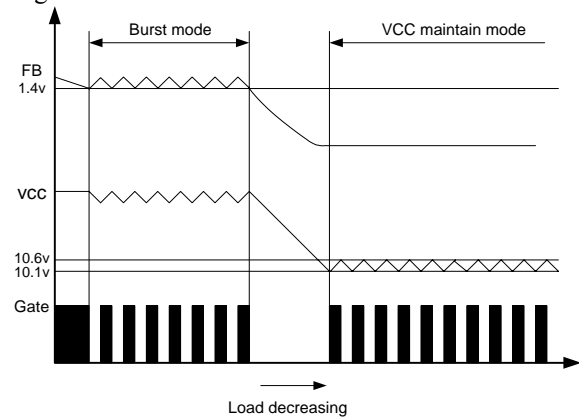

Figure 4. The Process of VCC Maintain Mode

## 3. PCB Layout Consideration

### 3.1 High Frequency Loop Consideration

As shown in Figure 5, there are four major high frequency current loops:

1. The current path from bulk capacitor, transformer, MOSFET,  $R_{CS}$  returning to bulk capacitor
2. The path from GATE pin, MOSFET,  $R_{CS}$  returning to the ground of IC

3. The RCD clamp circuit is a high frequency loop
4. Transformer, rectifier diode, and output capacitor is also a high frequency current loop

The loops must be as short as possible to decrease the radiate area for a better EMI, and if the MOSFET and Schottky diode have heat sink, the heat sink should be connected to their ground separately.

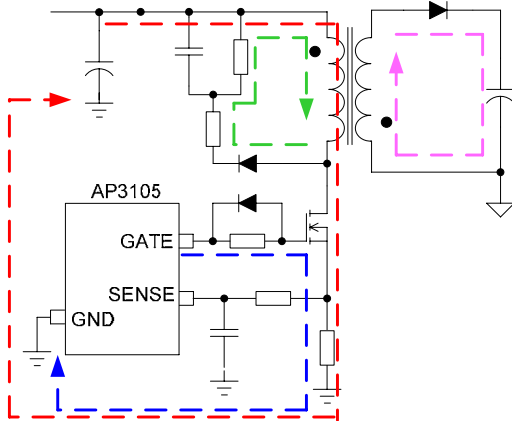

Figure 5. High Current Loop

In addition, the IC should not be placed in the loop of switching power trace, and in some applications, the power ground could be crossed over by the control signal (low current and low voltage), but the switching power trace with pulsating high voltage should not be crossed over.

### 3.2 ESD Consideration

Electro-Static Discharge (ESD) is an important testing item for switching power supply. The system's ability for bearing the test could be improved by designing a path to release the electric charge to the ground.

As shown in Figure 6, the red line represents the proposed path to release the charge. The copper tips for discharging should be placed between primary side and secondary side, but the distance between two copper tips should be consistent with the requirement of the safety specification.

The input common mode filter and differential mode filter will affect the effect of transient discharging, so the copper tips should be added and their distance should be as short as possible. Another way is placing a resistor paralleled with the inductor to replace the copper tip and the resistor's value is about 1kΩ to 5kΩ. A smaller resistor is helpful to ESD but has bad effect on lighting surge.

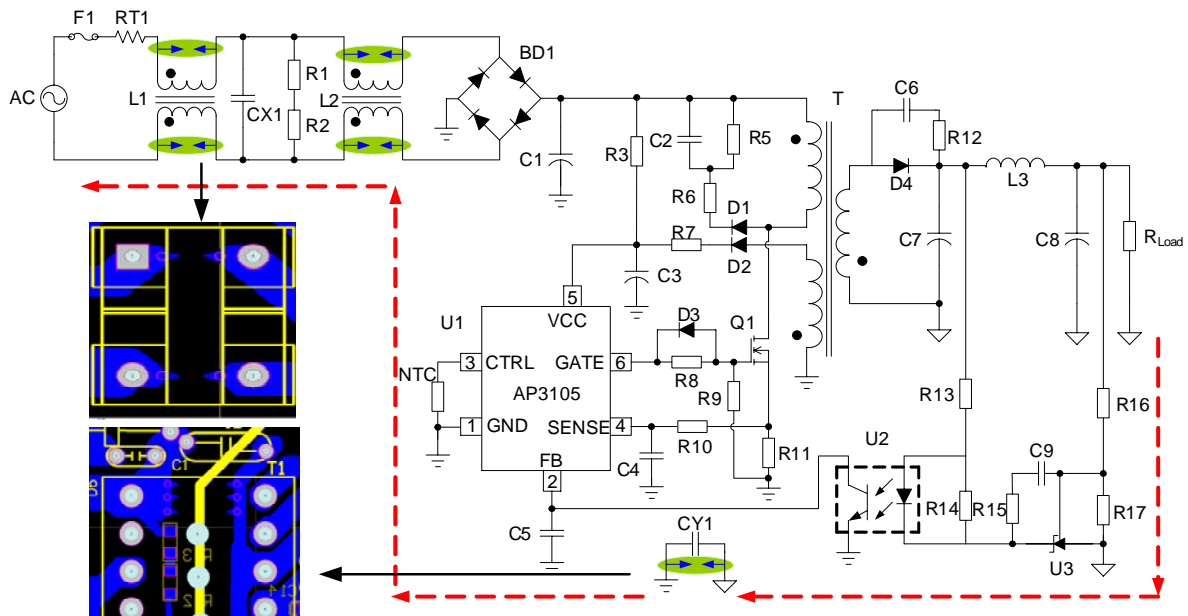

Figure 6. The Path of Release Charge of ESD

### 3.3 Ground Layout Consideration

A proper “Ground” layout is important to decrease unknown noise interference and EMI issue in the switching power supply.

A so-called “Star” connection is highly recommended for primary GND. As shown in Figure 7, the ground of MOSFET, auxiliary winding, Y-cap and control IC are separated and finally connected together on bulk capacitor ground. The width of these grounds should be kept as large as possible. The primary side of Y-cap could also be connected to the high voltage pin of the transformer.

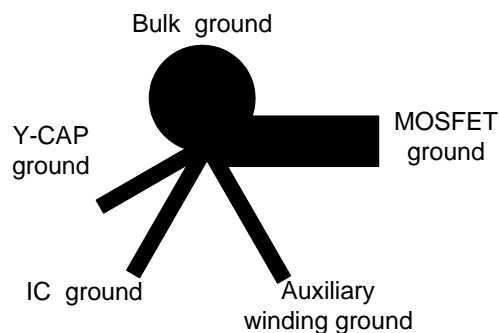

Figure 7. Star Connection of Primary GND

## 4. Standby Power Loss Reduction

Some methods are recommended here for reducing the standby power loss.

### 4.1 X-capacitor and X-resistor

A good quality X-capacitor will be helpful to save the standby power, and a low value X-cap could also decrease the X-cap loss. According to IEC 60950, for the X-cap exceeding  $0.1\mu\text{F}$ , the voltage will be decayed to 37% of its original value during an interval equal to one constant, and after calculating, the RC value is determined by the formula “ $R \times C < 1$ ”. Therefore, for a low value X-cap, a higher value X-resistor could be used, and the losses on X-resistor will be reduced.

### 4.2 Current Sampling Resistor

The value of current sampling resistor could affect the standby power. A lower value CS resistor is good for low standby power. But it also has effect on the OLP result, a lower value CS resistor will make a larger OLP point.

### 4.3 “SENSE” Pin RC Value

The value of “SENSE” pin RC could also affect the standby power. A larger value of RC can make the I-peak sense signal and the voltage on “FB” pin

smaller. A smaller voltage on “FB” pin will result in a lower operating frequency. It is good for achieving low standby power, but it will also make the OLP point larger.

### 4.4 The Output Voltage Dividing Resistor

The value of output voltage dividing resistor should be as high as possible, but the maximum value of the resistor connected to GND (R17 in Figure 6) should not exceed  $15\text{K}\Omega$ .

### 4.5 Primary RCD Clamp Circuit

To get a better standby power, the RCD clamp circuit could be replaced by a Transient Voltage Suppressor (TVS) and a diode (Figure 8). The advantage of the TVS clamp is that it only conducts when necessary and it is independent of the switching frequency. Compared to a RCD clamp, it reduces no-load power but increases costs and EMI. Besides, a lower value of RC is contributed to standby power, while the voltage stress on MOSFET should be in the spec.

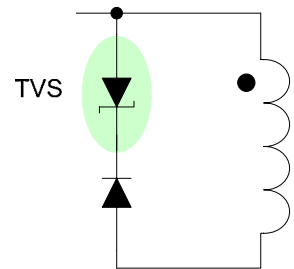

Figure 8. Clamp Circuit with TVS

### 4.6 Secondary Diode RC Snubber

A low value RC which parallel with Schottky could be helpful to the low standby power. The value should be adjusted to make the voltage stress on Schottky not exceed spec at turn-on.

## 5. Demo Design of 12V 1A Adaptor

12V 1A DEMO using flyback topology is designed, and the system specification is as follows:

- Output voltage and current: 12V/1A
- Input voltage range: 90Vac~265Vac

Table 3 is the test result of the standby power, and Table 4 shows the demo board components list. When the load is 12V/0A, the standby power is less than 60mW in the input voltage range under 230V. The power is measured by a power meter Chroma 66202. Figure 9 shows the application circuit schematic.

Input Voltage	90Vac/60Hz	115Vac/60Hz	180Vac/50Hz	230Vac/50Hz	264Vac/50Hz
Input Power	0.032W	0.0345W	0.0463W	0.0605W	0.0742W

Table 3. Test Result

R1,R2	RES,1206,510K,J	2	C1	CAP,Y1,1000pF,250V	1
R3	RES,1206,10Ω,J	1	C2,C3	CAP,AL,10μF,400V,Φ10mm, Rubycon, YXA, 105°C	2
R4	RES,1206,0Ω,J	1	C4	CAP,CD,222M,1KV	1
R5	RES,1206,1.5Ω,F	1	C5,C6	CAP,Low ESR, AL,470μF,16V,Φ8mm, CapXon, LZ	2
R6	RES,1206,10Ω,F	1	C7	CAP,AL,2.2μF,50V,Φ6.3mm, Rubycon, YXF	1
R7,R10	RES,1206,1.5M,J	2	C8	CAP,AL,22μF,50V,Φ6.3mm, Rubycon, YXF	1
R8	RES,0603,1K,J	1	C9	CAP,0805,102,100V,J	1
R9	RES,0603,10K,J	1	C11	CAP,0603,151,50V,J	1
R11	RES,0805,10Ω,J	1	C13	CAP,0603,683,50V,J	1
R12	RES,0603,24K,F	1	C14	CAP,0603,222,50V,J	1
R13	RES,0603,5.6K,J	1	D1~D6	DIODE,1N4007,1A,1000V,DO-41	6
R14	RES,0603,100K,J	1	D7,D8	DIODE,1N4148,0.15A,100V,LL-34	2
R15	RES,0603,91K,F	1	D9	DIODE,SCHOTTKY,SB3100, 3A,100V,DO-201	1
R16	RES,0805,0Ω,J	1	U1	IC,PWM,AP3105,SOT-23-6,BCD	1
R18	RES,1206,3K,J	1	U2	IC,OPTO COUPLER,PC817B,DIP-4	1
J1	BASE,3.96mm,3PIN,3N2	1	U3	IC,AS4311,TO-92,BCD	1
J2	BASE,3.96mm,2PIN	1	F1	FUSE,CUBIFORM,SLOW,1A,250V	1
T1	XFM,EF-20,102Ts,1.6mH	1	L2	CHOKE,FER,DR6*8,1.5mH, 0.3A, Φ6mm	1
Q1	MOSFET-N, 1A,600V,TO-251,STD1NA60	1	L3	CHOKE,2.2μH	1

Table 4. BOM of DEMO BOARD (12V/1A)

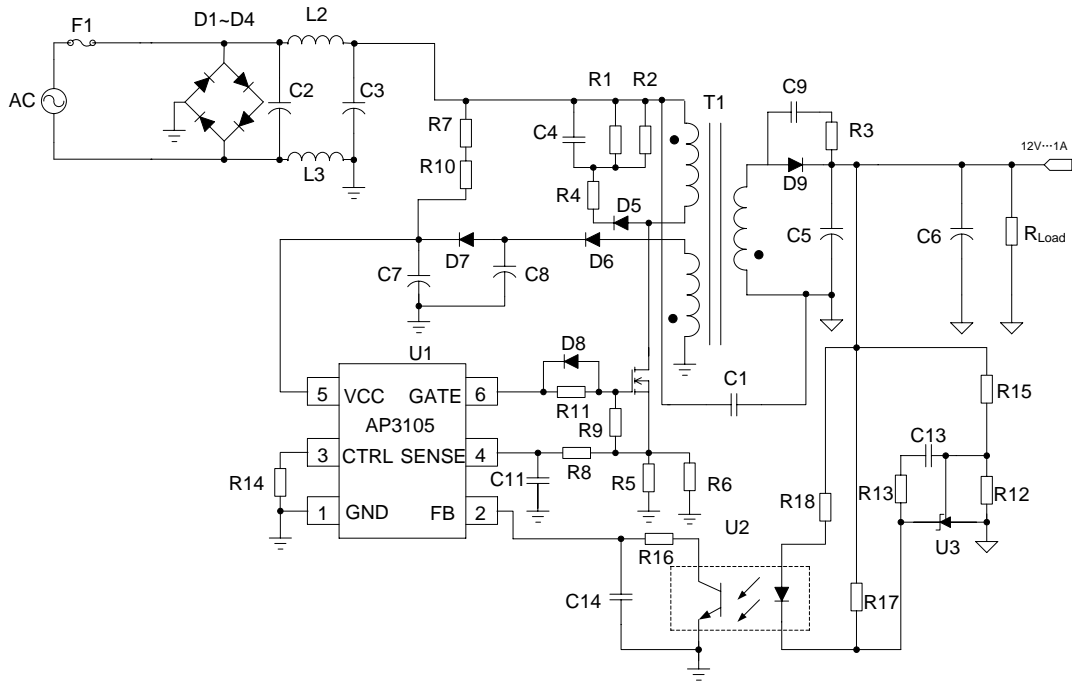

Figure 9. Application Circuit Schematic