

**Features**

- LED driving current up to 1A
- High efficiency up to 92%
- Operating input voltage up to 48V
- High switching frequency up to 500kHz
- PWM/DC input for dimming control
- Built-in output open-circuit protection
- SOP-8L, SOP-8L-EP and DFN3030-10 are available in "Green" Molding Compound (No Br, Sb)
- Lead Free Finish/ RoHS Compliant (Note 1)

**General Description**

The AP8802 is a step-down DC/DC converter designed to drive LEDs with a constant current. The device can drive up to thirteen LEDs, depending on the forward voltage of the LEDs, in series from a voltage source of 8V to 48V. Series connection of the LEDs provides identical LED currents resulting in uniform brightness and eliminating the need for ballast resistors. The AP8802 switches at frequency up to 500kHz. This allows the use of small size external components, hence minimizing the PCB area needed.

Maximum output current of AP8802 is set via an external resistor connected between the  $V_{IN}$  and SET input pins. Dimming is achieved by applying either a DC voltage or a PWM signal at the CTRL input pin. An input voltage of 0.2V or lower at CTRL shuts down the output at SW and puts the device into a low-current standby state.

**Applications**

- Commercial & industrial lighting
- Small LCD panel backlight
- Appliances interior lighting
- Architecture Detail lighting

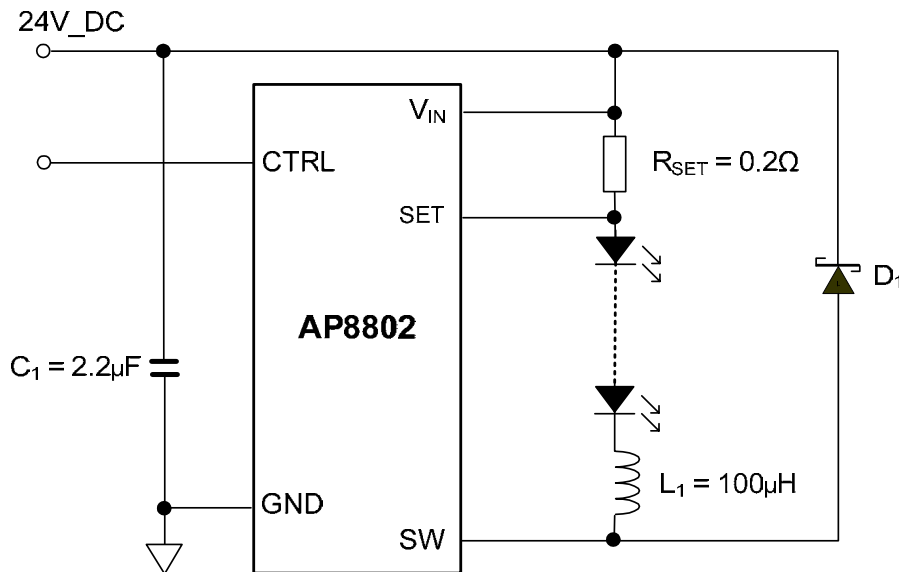

**Typical Application Circuit**

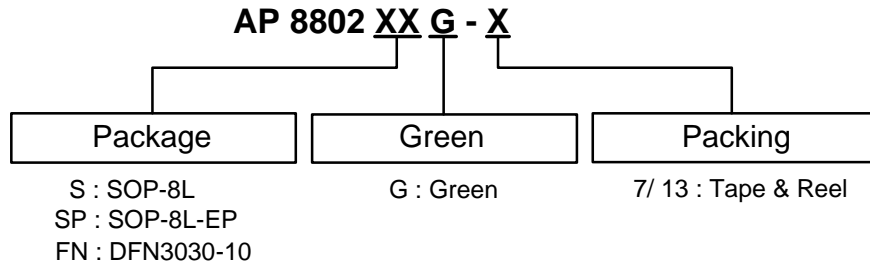

**Figure 1: Typical Application Circuit**

### Ordering Information



Device	Package Code	Packaging (Note 2)	7"/13" Tape and Reel	
			Quantity	Part Number Suffix
 AP8802SG-13	S	SOP-8L	2500/Tape & Reel	-13
 AP8802SPG-13	SP	SOP-8L-EP	2500/Tape & Reel	-13
 AP8802FNG-7	FN	DFN3030-10	3000/Tape & Reel	-7

- Notes:
1. EU Directive 2002/95/EC (RoHS). All applicable RoHS exemptions applied. Please visit our website at [http://www.diodes.com/products/lead\\_free.html](http://www.diodes.com/products/lead_free.html).
  2. Pad layout as shown on Diodes Inc. suggested pad layout document AP02001, which can be found on our website at <http://www.diodes.com/datasheets/ap02001.pdf>.

### Pin Assignments

(1) SOP-8L

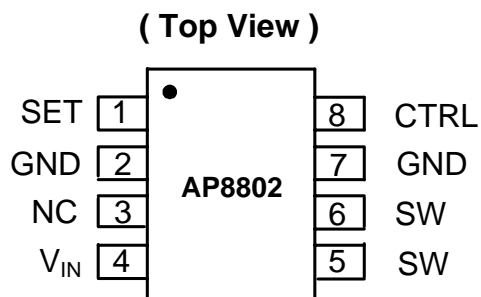

(2) SOP-8L-EP

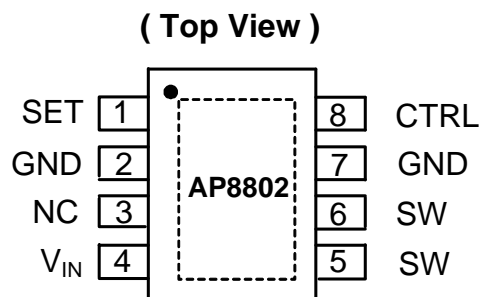

(3) DFN3030-10

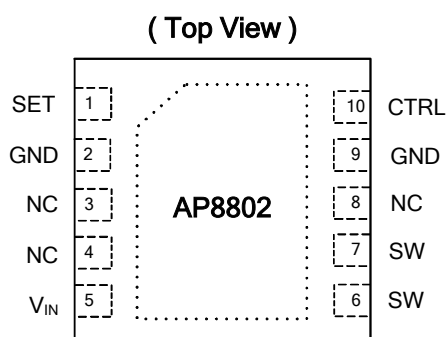

### Pin Descriptions

Pin Name	Description
SW	Switch Pin. Connect inductor/freewheeling diode here, minimizing track length at this pin to reduce EMI.
GND	GND pin
SET	Set Nominal Output Current Pin. Configure the output current of the device.
CTRL	Dimming and On/Off Control Input. Input voltage of 0.2V or lower forces the device into low current standby mode and shuts off the output. A PWM signal allows the output current to be adjusted above or below the level set by the resistor connected to SET input pin. The input impedance is about 50kΩ, and if the pin is left open $V_{CTRL} = V_{REF}$
$V_{IN}$	Input Supply Pin. Must be locally bypassed.
NC	No connection

**Block Diagram**

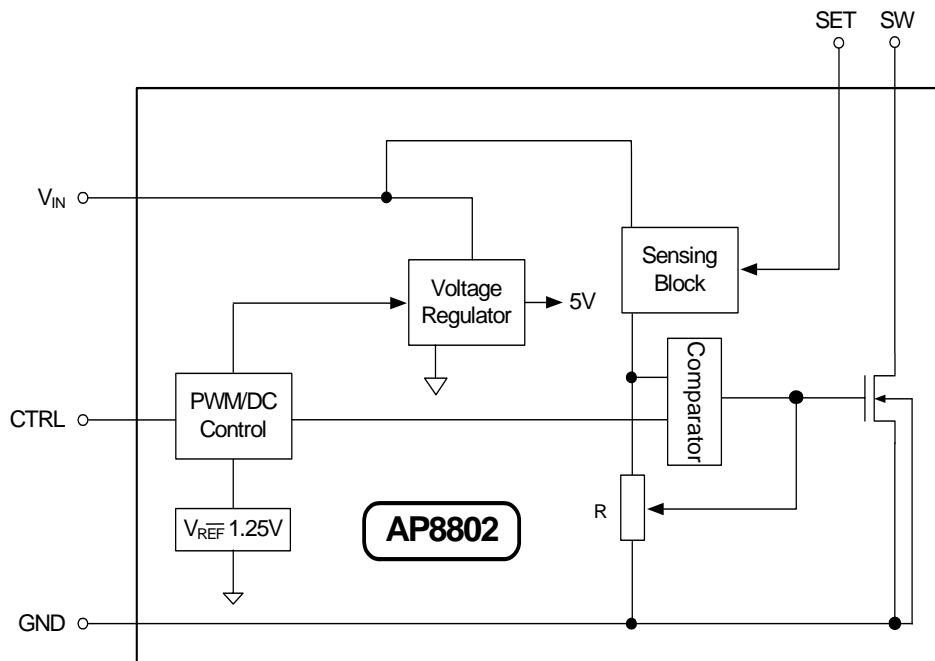

Figure 2: AP8802 block diagram

**Absolute Maximum Ratings**

Symbol	Parameter	Rating	Unit
$V_{IN}$	VIN pin voltage	-0.3~50	V
$V_{SW}$	SW voltage	-0.3~50	V
$T_J$	Junction Temperature	150	°C
$T_{LEAD}$	Lead Temperature Soldering	300	°C
$T_{ST}$	Storage Temperature Range	-65 to +150	°C

Caution: The absolute maximum ratings are rated values exceeding which the product could suffer physical damage. These values must therefore not be exceeded under any condition. Semiconductor devices are ESD sensitive and may be damaged by exposure to ESD events. Suitable ESD precautions should be taken when handling and transporting these devices

**Recommended Operating Conditions**

Symbol	Parameter	Min	Max	Unit
$T_A$	Ambient Temperature Range	-40	105	°C

### Electrical Characteristics ( $V_{IN}=12V$ , $T_A=25^{\circ}C$ , unless otherwise specified)

Symbol	Parameter	Conditions	Min	Typ.	Max	Unit
$V_{IN}$	Operating Input Voltage		8.0	-	48	V
$I_{OUT}$	Continuous switch current	(Note 3)			1	A
$I_Q$	Quiescent Current		-	75	120	$\mu A$
$F_{OSC}$	Switching Frequency		-	-	0.5	MHz
$V_{THD}$	Internal Threshold Voltage		184	200	216	mV
$V_{REF}$	Internal Reference Voltage		-	1.25	-	V
SET	SET pin input current	$V_{SET}=V_{IN}-0.2$	-	5	-	$\mu A$
$R_{ds(on)}$	On Resistance of MOSFET	$I_{SW}=0.8A$		0.65	1.1	$\Omega$
$I_{SW\ Leakage}$	Switch leakage current		-	-	8	$\mu A$
EN	Voltage High	ON	1.25	-	-	V
EN	Voltage Low	OFF	-	-	0.2	V
$\theta_{JA}$	Thermal Resistance Junction-to-Ambient	SOP-8L (Note 4)	-	82	-	$^{\circ}C/W$
		SOP-8L-EP (Note 4)	-	45	-	$^{\circ}C/W$
		DFN3030-10 (Note 4)	-	38	-	$^{\circ}C/W$
$\theta_{JC}$	Thermal Resistance Junction-to-Case	SOP-8L (Note 4)	-	52	-	$^{\circ}C/W$
		SOP-8L-EP (Note 4)	-	7	-	$^{\circ}C/W$
		DFN3030-10 (Note 4)	-	24	-	$^{\circ}C/W$

Notes: 3. Refer to figure 8 for the device derating curve.

4. Test condition for SOP-8L, SOP-8L-EP and DFN3030-10: Device mounted on FR-4 PCB, 2"x2", 2oz copper, minimum recommended pad layout on top layer and thermal vias to bottom layer ground plane. For better thermal performance, larger copper pad for heat-sink is needed.

## Application Information

### LED Current Control

The LED current is controlled by the resistor RSET in Figure 1 connected between VIN and SET. The nominal average output current in the LED(s) is defined as:

$$I_{LED} = \frac{V_{THD}}{R_{SET}}$$

If the CTRL pin is driven by an external voltage (lower than 2.5V), the average LED current is:

$$I_{LED} = \frac{V_{CTRL}}{V_{REF}} \frac{V_{THD}}{R_{SET}}$$

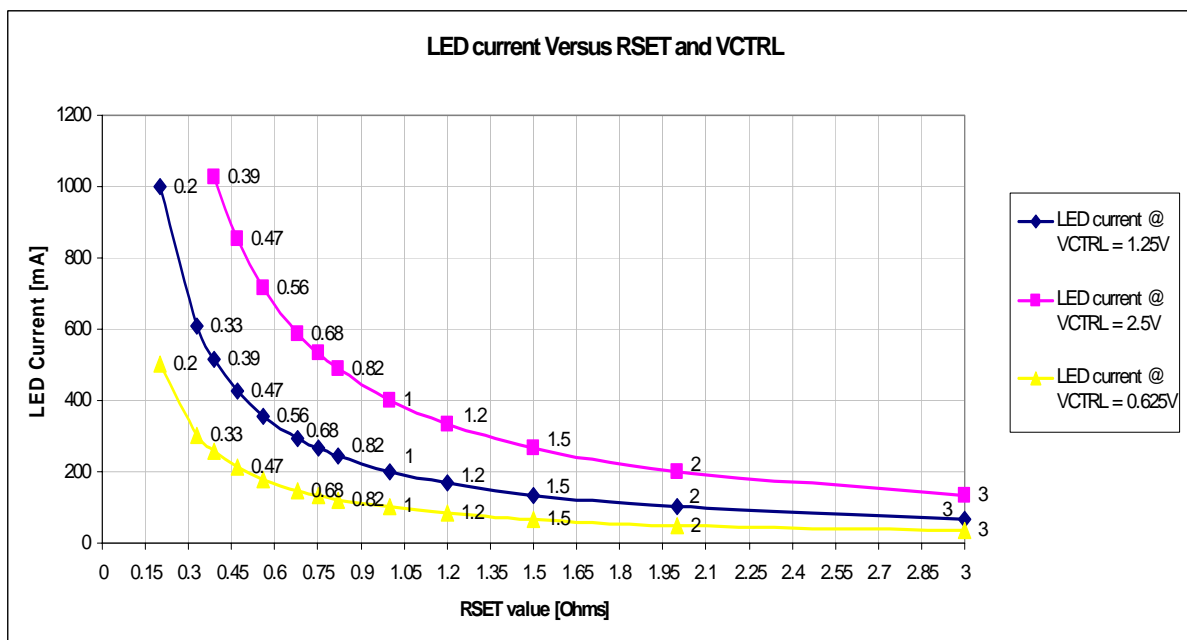
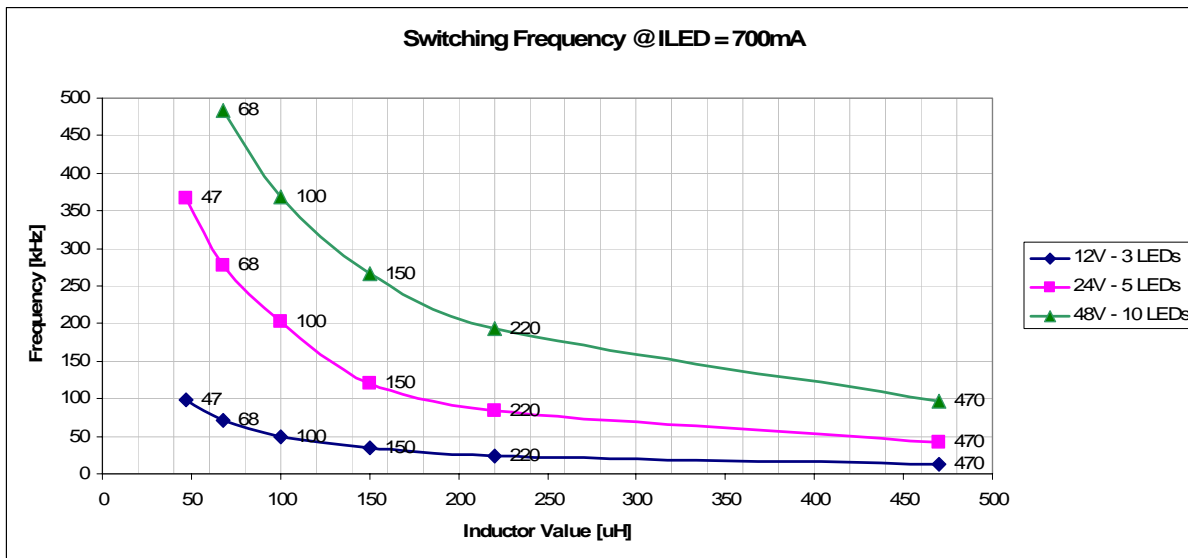

Figure 3: LED Current setting Vs RSET and VCTRL

**Application Information (Continued)**

**Inductor Selection**

This section highlights how to select the inductor suitable for the application requirements in terms of switching frequency, LED current accuracy and temperature.

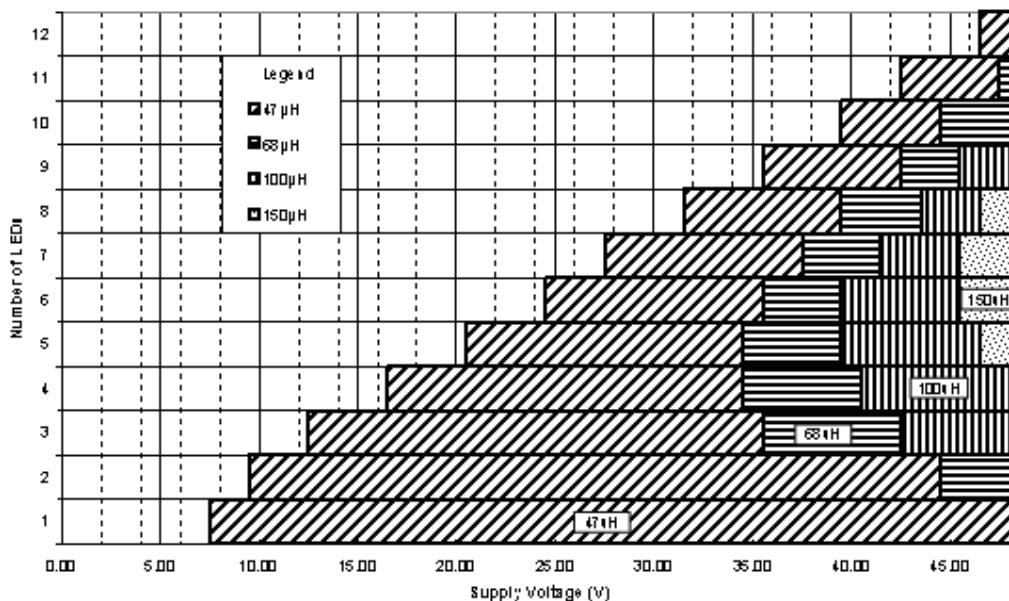

**Figure 4: Switching Frequency Vs Inductor Value**

The inductor influences the LED current accuracy that the system is able to provide. The following section highlights how to select the inductor in relation to the device packages and the LED current, while maintaining the chip temperature below 70°C.

**Application Information (Continued)**

AP8802 DFN3030-10 Minimum Recommended Inductor  
8% Accuracy, -70°C Case Temperature



**Figure 5: DFN3030-10 recommended inductor with 1A LED current**

AP8802 SOP8EP Minimum Recommended Inductor  
8% Accuracy, -70°C Case Temperature

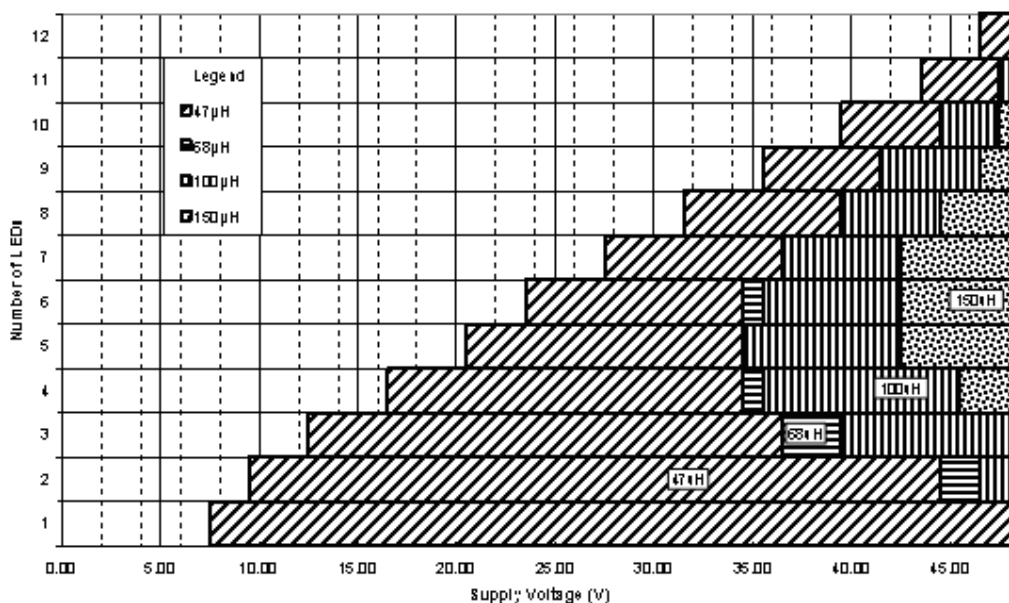

**Figure 6: SOP8L-EP recommended inductor with 1A LED current**

**Application Information (Continued)**

**AP8802 SOP-8L Minimum Recommended Inductor**  
8% Accuracy, <70°C Case Temperature

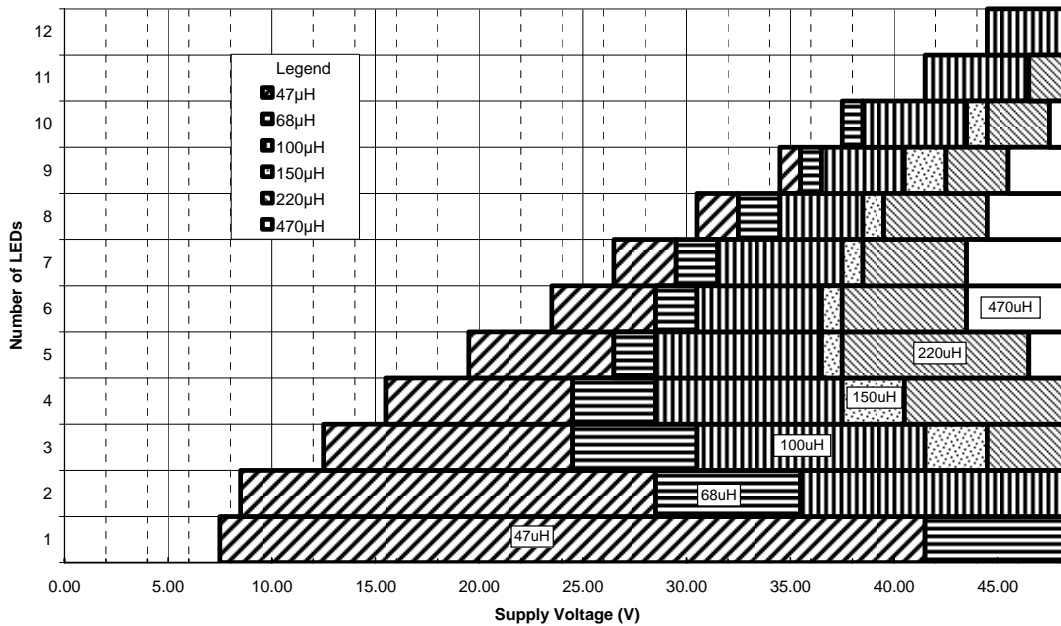

**Figure 7: SOP-8L recommended inductor with 700mA LED current**

**Application Information (Continued)**

**Capacitor Selection**

The small size of ceramic capacitors makes them ideal for AP8802 applications. X5R and X7R types are recommended because they retain their capacitance over wider voltage and temperature ranges than other types such as Z5U. A 2.2 $\mu$ F input capacitor is sufficient for most intended applications of AP8802. A 4.7 $\mu$ F input capacitor is suggested for application with an input voltage equal or higher than 40V.

**Diode Selection**

Schottky diodes, e.g. B2100 or B1100, with their low forward voltage drop and fast reverse recovery, are the ideal choice for AP8802 applications.

**PWM Dimming**

A Pulse Width Modulated (PWM) signal with a max resolution of 8bit, can be applied to the CTRL pin to change the output current to a value above or below the nominal average value set by resistor RSET. To achieve this resolution the PWM frequency has to be lower than 500Hz.

**Thermal Considerations**

The graph below in figure 8, gives details for power derating. This assumes the device to be mounted on a 25x25mm PCB with 1oz copper standing in still air.

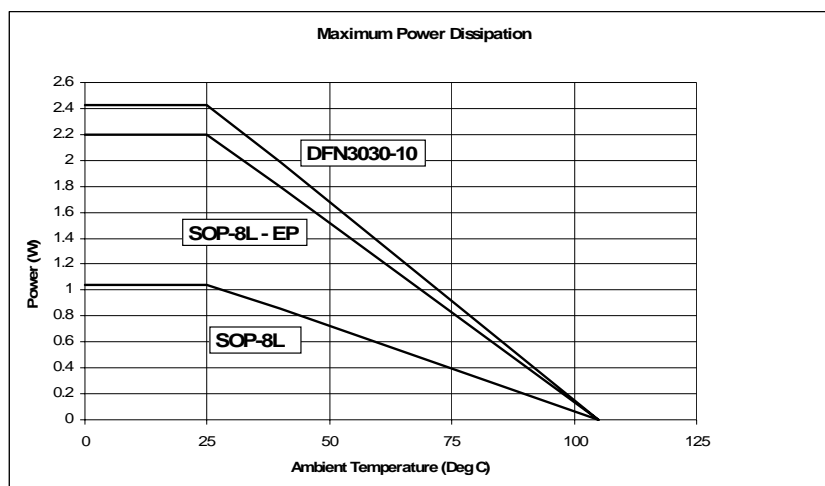

**Figure 8: AP8802 derating curves**

**Package Selection**

The device comes with a wide selection of packages. The suggested package is able to provide a case temperature below 70°C (with an ambient temperature of 25°C) for the combination of input voltage and load requested.

**Application Information (Continued)**

AP8802 - suggested package @  
ILED=1A and 100µH Inductor

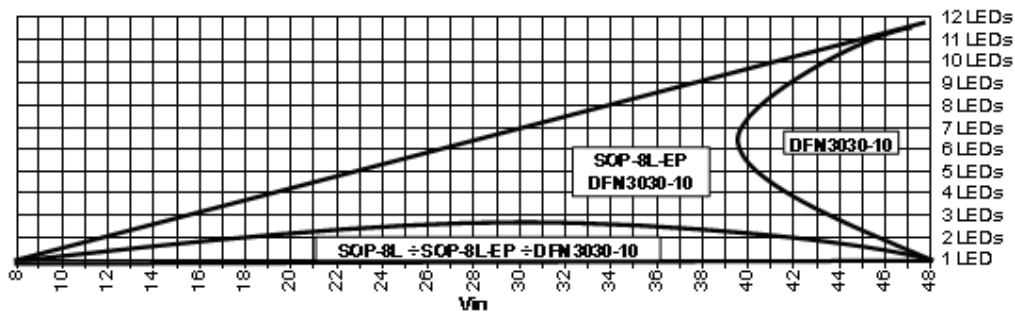

Figure 9: Suggested package for a 1A application

AP8802 - suggested package @  
ILED=700mA and 100µH Inductor

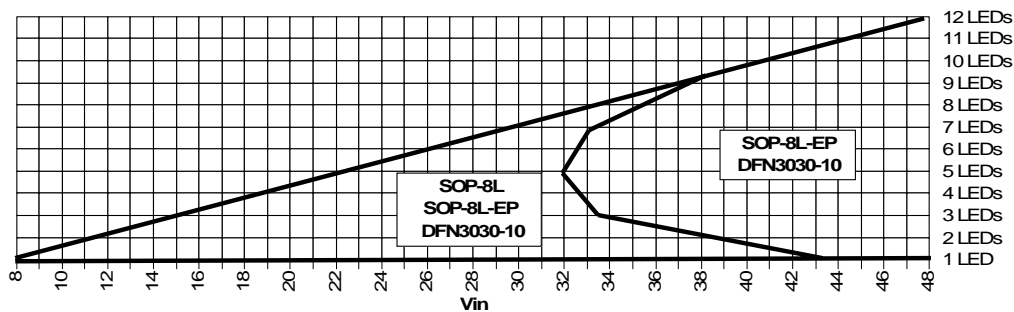
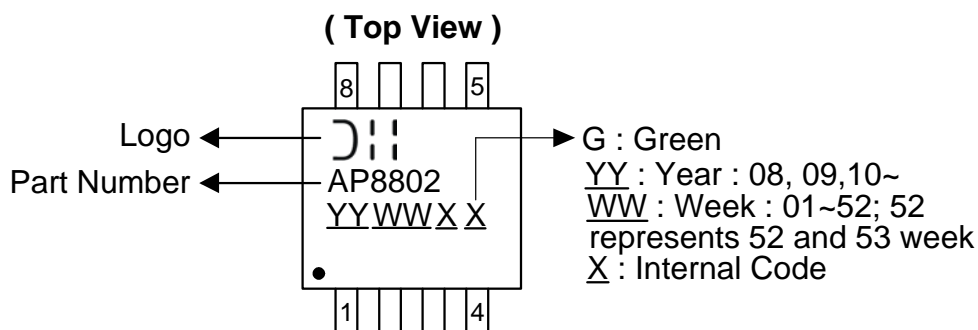

Figure 10: Suggested package for a 700mA application

### Marking Information

#### (1) SOP-8L



#### (2) SOP-8L-EP

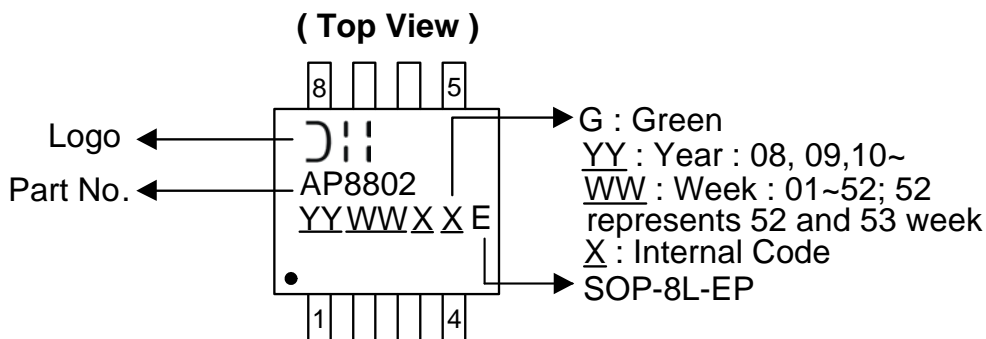

#### (3) DFN3030-10

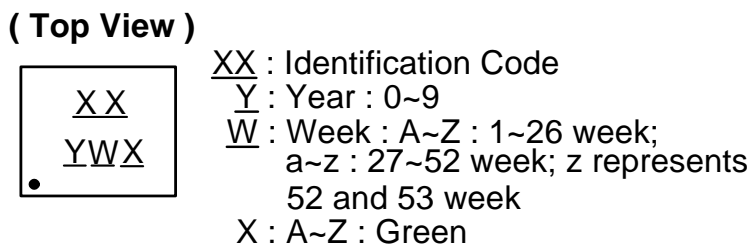

Part Number	Package	Identification Code
AP8802FNG-7	DFN3030-10	A5

**Package Information (All Dimensions in mm)**

**(1) Package Type: SOP-8L**

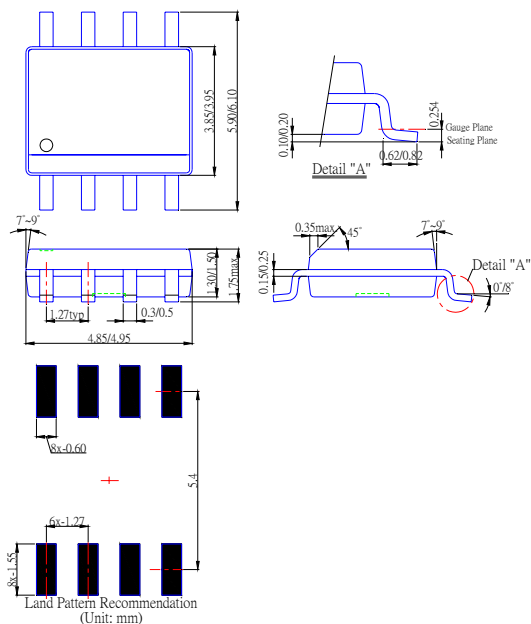

**(2) Package Type: SOP-8L-EP**

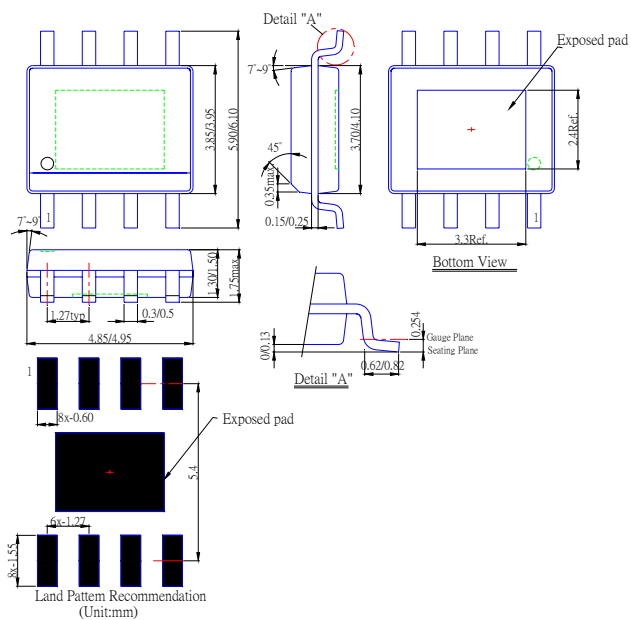

**Package Information (Continued)**

**(3) Package Type: DFN3030-10**

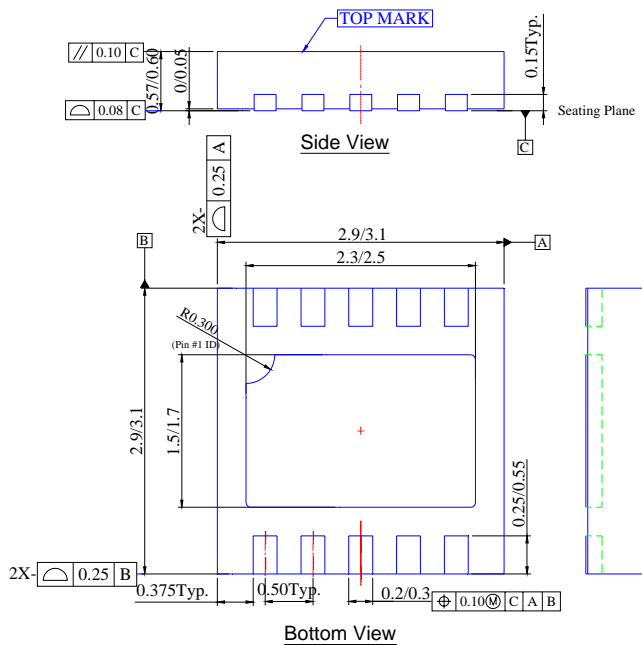

---

## Taping Orientation

---

For DFN3030-10

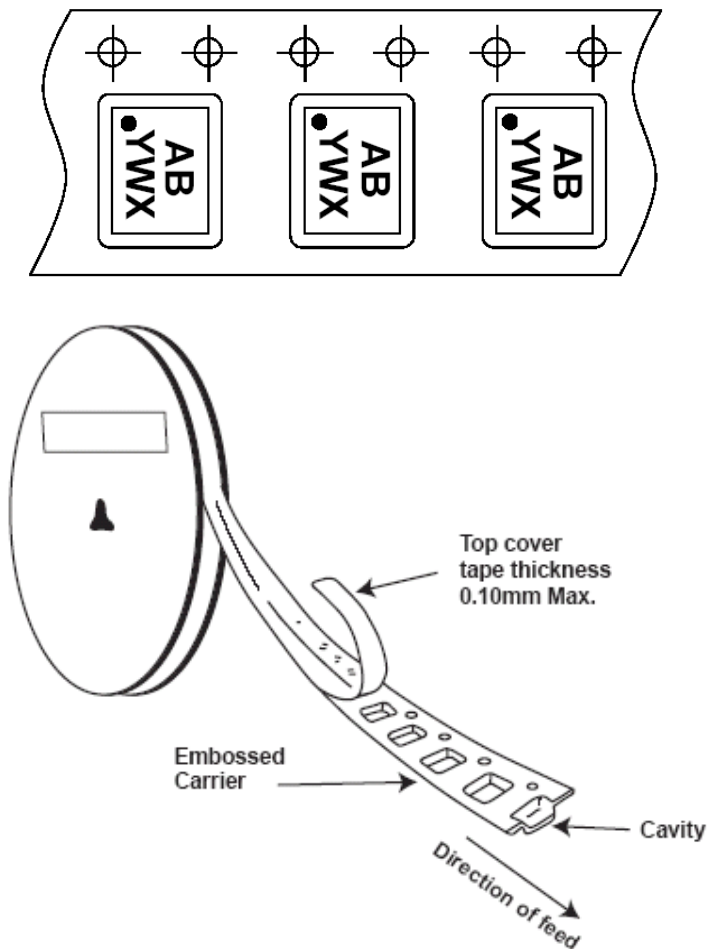

Notes: 5. The taping orientation of the other package type can be found on our website at <http://www.diodes.com/datasheets/ap02007.pdf>.

**IMPORTANT NOTICE**

DIODES INCORPORATED MAKES NO WARRANTY OF ANY KIND, EXPRESS OR IMPLIED, WITH REGARDING TO THIS DOCUMENT, INCLUDING, BUT NOT LIMITED TO, THE IMPLIED WARRANTIES OF MERCHANTABILITY AND FITNESS FOR A PARTICULAR PURPOSE (AND THEIR EQUIVALENTS UNDER THE LAWS OF ANY JURISDICTION).

Diodes Incorporated and its subsidiaries reserve the right to make modifications, enhancements, improvements, corrections or other changes without further notice to this document and any product described herein. Diodes Incorporated does not assume any liability arising out of the application or use of this document or any product described herein; neither does Diodes Incorporated convey any license under its patent or trademark rights, nor the rights of others. Any Customer or user of this document or products described herein in such applications shall assume all risks of such use and will agree to hold Diodes Incorporated and all the companies whose products are represented on Diodes Incorporated website, harmless against all damages.

Diodes Incorporated does not warrant or accept any liability whatsoever in respect of any products purchased through unauthorized sales channel.

Should Customers purchase or use Diodes Incorporated products for any unintended or unauthorized application, Customers shall indemnify and hold Diodes Incorporated and its representatives harmless against all claims, damages, expenses, and attorney fees arising out of, directly or indirectly, any claim of personal injury or death associated with such unintended or unauthorized application.

Products described herein may be covered by one or more United States, international or foreign patents pending. Product names and markings noted herein may also be covered by one or more United States, international or foreign trademarks.

**LIFE SUPPORT**

Diodes Incorporated products are specifically not authorized for use as critical components in life support devices or systems without the express written approval of the Chief Executive Officer of Diodes Incorporated. As used herein:

- A. Life support devices or systems are devices or systems which:
1. are intended to implant into the body, or
  2. support or sustain life and whose failure to perform when properly used in accordance with instructions for use provided in the labeling can be reasonably expected to result in significant injury to the user.
- B. A critical component is any component in a life support device or system whose failure to perform can be reasonably expected to cause the failure of the life support device or to affect its safety or effectiveness.

Customers represent that they have all necessary expertise in the safety and regulatory ramifications of their life support devices or systems, and acknowledge and agree that they are solely responsible for all legal, regulatory and safety-related requirements concerning their products and any use of Diodes Incorporated products in such safety-critical, life support devices or systems, notwithstanding any devices- or systems-related information or support that may be provided by Diodes Incorporated. Further, Customers must fully indemnify Diodes Incorporated and its representatives against any damages arising out of the use of Diodes Incorporated products in such safety-critical, life support devices or systems.

Copyright © 2009, Diodes Incorporated

[www.diodes.com](http://www.diodes.com)