

Features

- Bipolar Hall Effect Latch Sensor
- 3V to 20V DC Operation Voltage
- Built-in Pull-Up Resistor
- 25mA Output Sink Current
- Operating Temperature: -40°C ~ +125°C
- Lead Free Packages: SC59-3L and SIP-3L (Note 1)
- SC59-3L (commonly known as SOT23 in Asia): Available in "Green" Molding Compound (No Br, Sb)
- Lead Free Finish/ RoHS Compliant (Note 2)

General Description

AH173 is a single-digital-output Hall-effect sensor with pull-up resistor for high temperature operation. The device includes an on-chip Hall voltage generator for magnetic sensing, an amplifier to amplify Hall voltage, and a comparator to provide switching hysteresis for noise rejection, and an output driver with a pull-up resistor (Rpu). An internal band-gap regulator is used to provide temperature compensated supply voltage for internal circuits and allows a wide operating supply range. While the magnetic flux density (B) is larger than operate point (Bop), the OUT pin turns on (low). If B moves toward release point (Brp), the OUT pin is latched "on" state prior to B < Brp. When B < Brp, the OUT pin goes into "off" state.

Applications

- Rotor Position Sensing
- Current Switch
- Encoder
- RPM Detection

Ordering Information

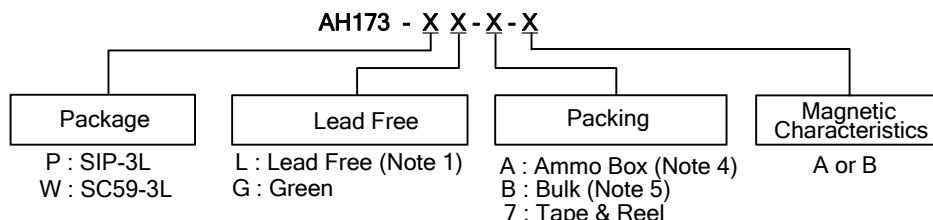

Device	Package Code	Packaging (Note 3)	Tube/Bulk		7" Tape and Reel		Ammo Box		Magnetic Characteristics
			Quantity	Part Number Suffix	Quantity	Part Number Suffix	Quantity	Part Number Suffix	
AH173-PL-A-A	P	SIP-3L	NA	NA	NA	NA	4000/Box	-A	A
AH173-PL-A-B	P	SIP-3L	NA	NA	NA	NA	4000/Box	-A	B
AH173-PL-B-A	P	SIP-3L	1000	-B	NA	NA	NA	NA	A
AH173-PL-B-B	P	SIP-3L	1000	-B	NA	NA	NA	NA	B
AH173-WL-7-A	W	SC59-3L	NA	NA	3000/Tape & Reel	-7	NA	NA	A
AH173-WL-7-B	W	SC59-3L	NA	NA	3000/Tape & Reel	-7	NA	NA	B
AH173-WG-7-A	W	SC59-3L	NA	NA	3000/Tape & Reel	-7	NA	NA	A
AH173-WG-7-B	W	SC59-3L	NA	NA	3000/Tape & Reel	-7	NA	NA	B



- Notes:
1. SIP-3L is available in "Lead Free" product only.
 2. EU Directive 2002/95/EC (RoHS). All applicable RoHS exemptions applied. Please visit our website at http://www.diodes.com/products/lead_free.html.
 3. Pad layout as shown on Diodes Inc. suggested pad layout document AP02001, which can be found on our website at <http://www.diodes.com/datasheets/ap02001.pdf>.
 4. Ammo Box is for SIP-3L Spread Lead.
 5. Bulk is for SIP-3L Straight Lead.

Pin Assignment

(1) SIP-3L

(2) SC59-3L

(Top View)

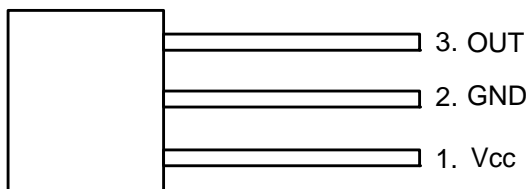

(Top View)

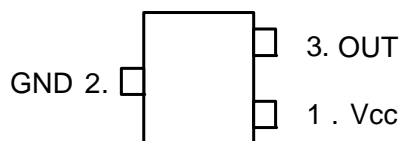

Pin Descriptions

Pin Name	Pin #	Description
Vcc	1	Positive Power Supply
GND	2	Ground
OUT	3	Output Stage

Block Diagram

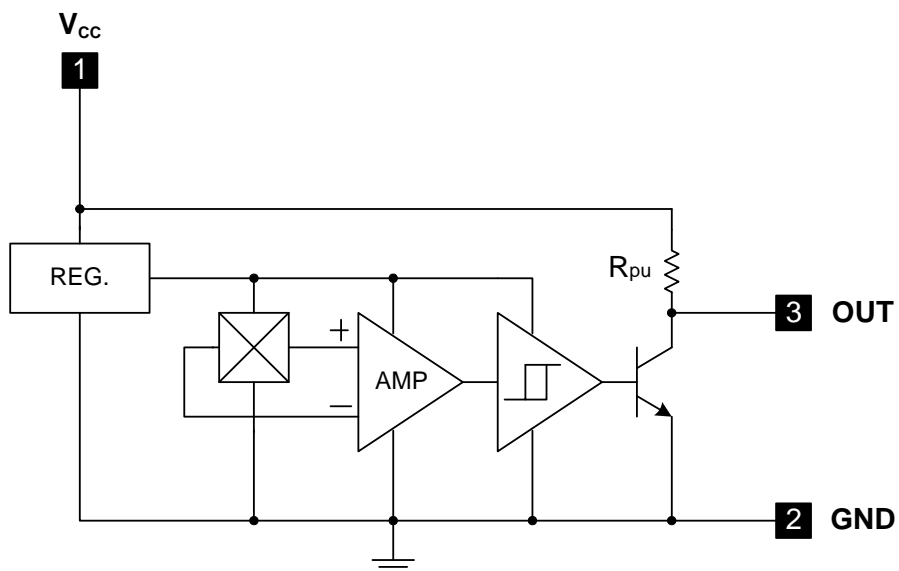

Functional Application Circuit

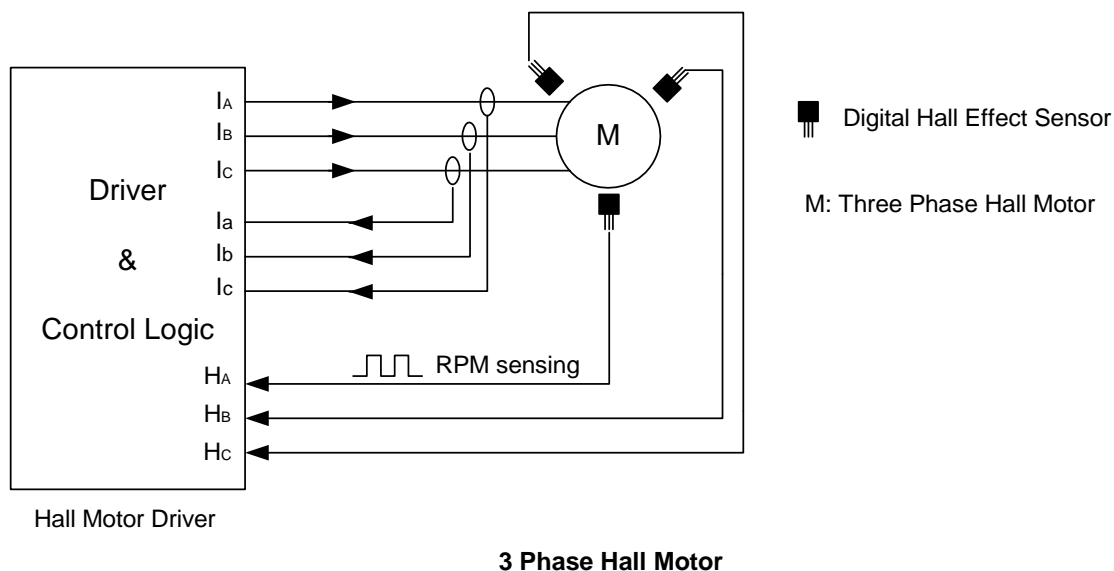

Absolute Maximum Ratings ($T_A = 25^\circ\text{C}$)

Symbol	Characteristics	Values	Unit	
V_{CC}	Supply Voltage	20	V	
$V_{OUT (off)}$	Output "Off" Voltage	20	V	
$I_O (sink)$	Output "On" Current	25	mA	
T_S	Storage Temperature Range	-65~+150	$^\circ\text{C}$	
T_J	Maximum Junction Temperature	+150	$^\circ\text{C}$	
P_D	Power Dissipation	SIP-3L	550	mW
		SC59-3L	230	mW

Recommended Operating Conditions

Symbol	Characteristic	Conditions	Min	Max	Unit
V_{CC}	Supply Voltage	Operating	3	20	V
T_A	Operating Ambient Temperature	Operating	-40	125	$^\circ\text{C}$

Electrical Characteristics (T_A = 25°C)

Symbol	Characteristics	Conditions	Min	Typ.	Max	Unit
V _{OUT (SAT)}	Output Saturation Voltage	V _{CC} = 12V, OUT "ON" I _O = 10mA	-	300	400	mV
I _{CC}	Supply Current	V _{CC} = 12V, OUT "OFF"	-	3.5	6	mA
R _{pu}	Internal Pull-up Resistor		7	10	13	KΩ
V _d	Dropout Voltage	V _d = V _{CC} - V _{Ce}	-	-	0.3	V

Magnetic Characteristics (T_A = 25°C, V_{CC} = 12V)

(1mT = 10 Gauss)

A grade

Symbol	Characteristics	Min	Typ.	Max	Unit
B _{ops} (south pole to brand side)	Operation Point	15	-	60	Gauss
B _{rps} (south pole to brand side)	Release Point	-60	-	-15	Gauss
B _{hy} (B _{opx} - B _{rpx})	Hysteresis	-	80	-	Gauss

B grade

Symbol	Characteristics	Min	Typ.	Max	Unit
B _{ops} (south pole to brand side)	Operation Point	5	-	80	Gauss
B _{rps} (south pole to brand side)	Release Point	-80	-	-5	Gauss
B _{hy} (B _{opx} - B _{rpx})	Hysteresis	-	80	-	Gauss

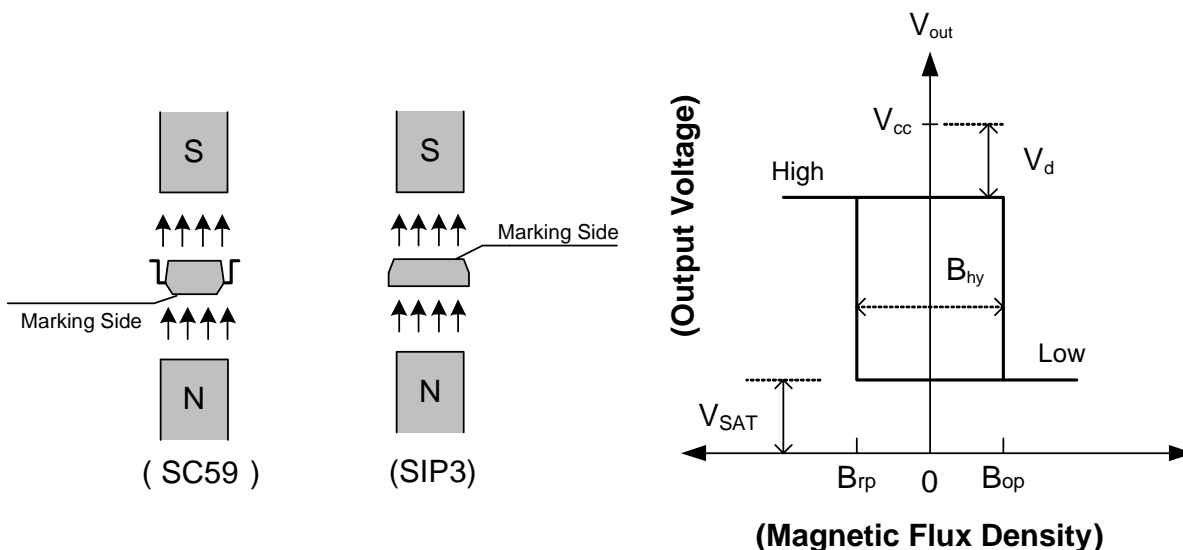

Performance Characteristics

(1) SIP-3L

T_A (°C)	25	50	60	70	80	85	90	95	100
P_D (mW)	550	440	396	352	308	286	264	242	220
T_A (°C)	105	110	115	120	125	130	135	140	150
P_D (mW)	198	176	154	132	110	88	66	44	0

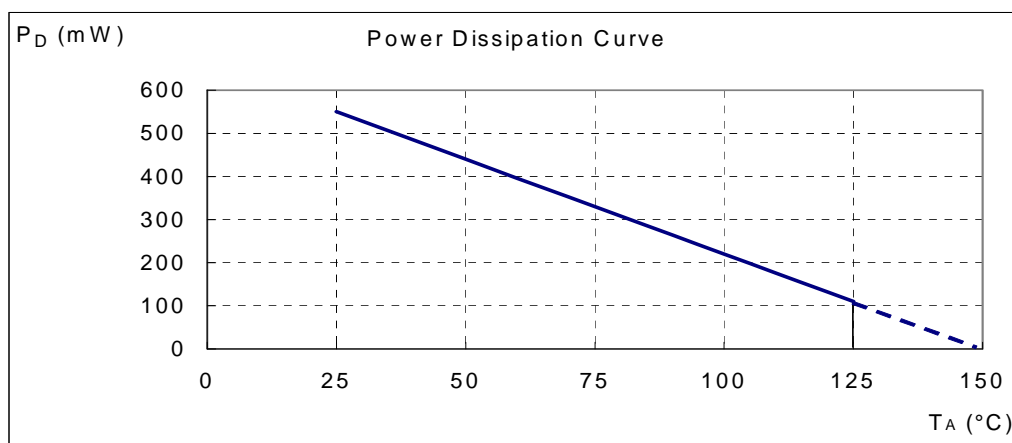

(2) SC59-3L (commonly known as SOT23 in Asia)

T_A (°C)	25	50	60	70	80	85	90	100	110	120	130	140	150
P_D (mW)	230	184	166	147	129	120	110	92	74	55	37	18	0

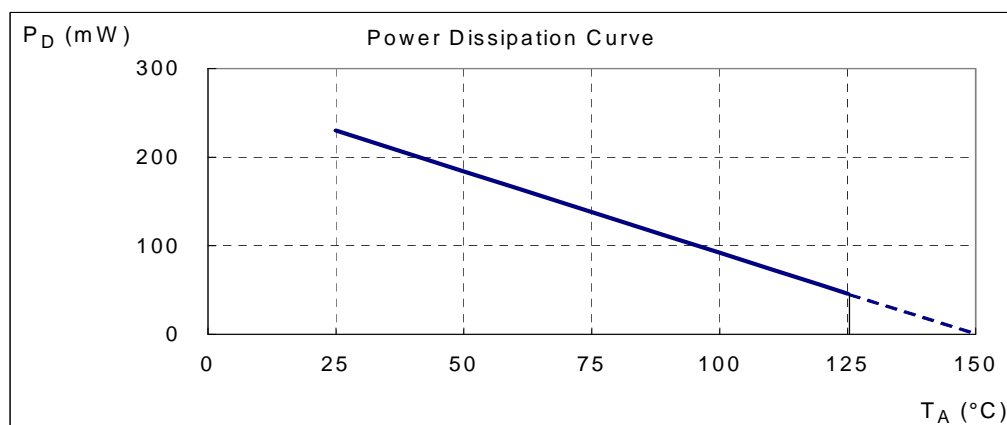

Marking Information

(1) SIP3-3L

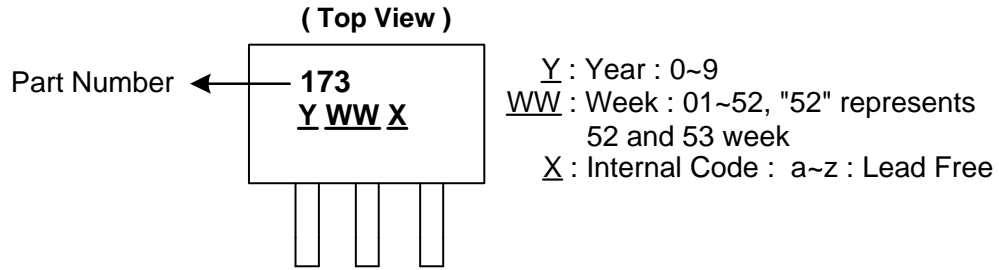

(2) SC59 (Commonly known as SOT23 in Asia)

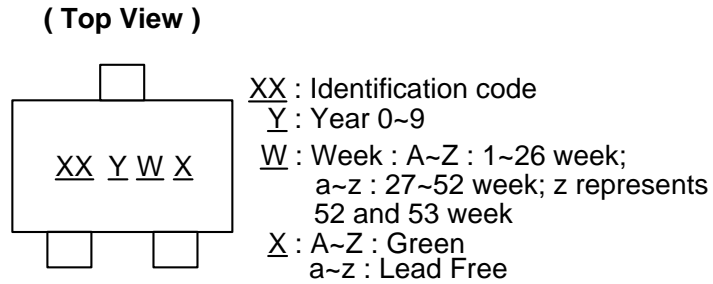

Part Number	Package	Identification Code
AH173	SC59-3L	J3

Package Information (All Dimensions in mm)

(1) Package Type: SIP-3L for Bulk pack

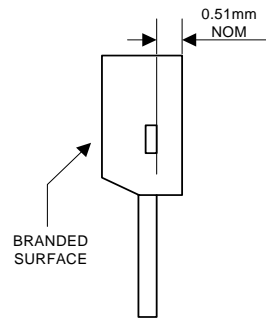

Active Area Depth

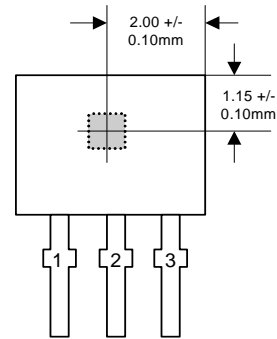

Sensor Location

Package Dimension

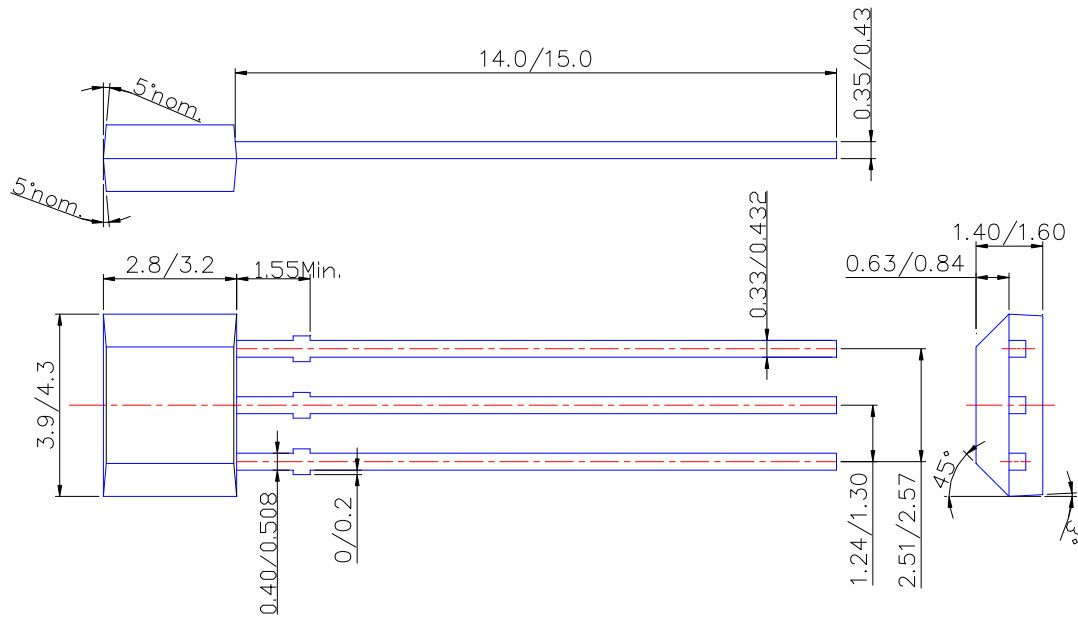

Package Information (Continued)

(2) Package Type: SIP-3L for Ammo pack

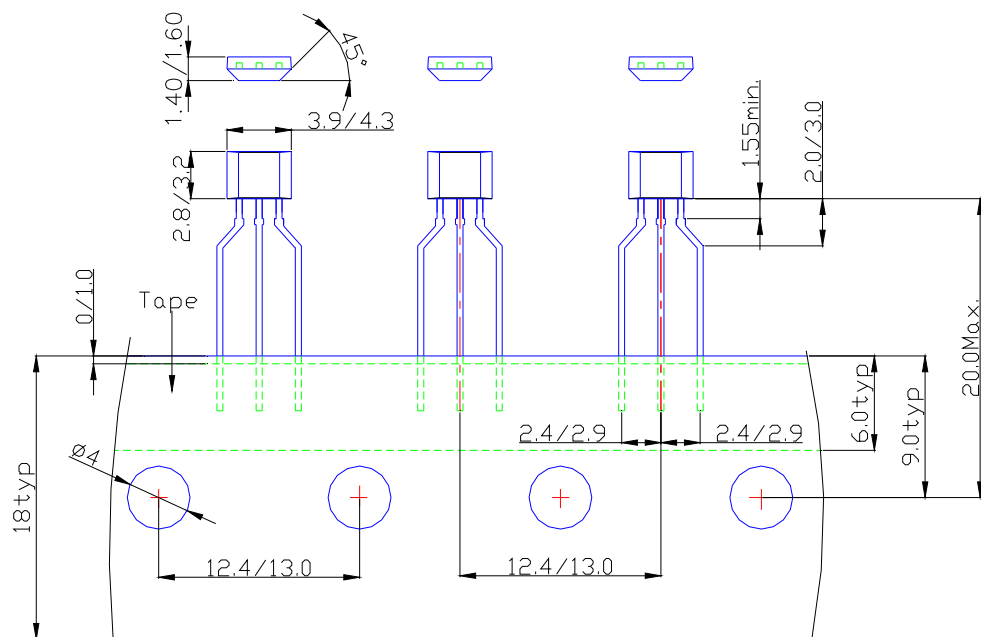

(3) SC59 (Commonly known as SOT23 in Asia)

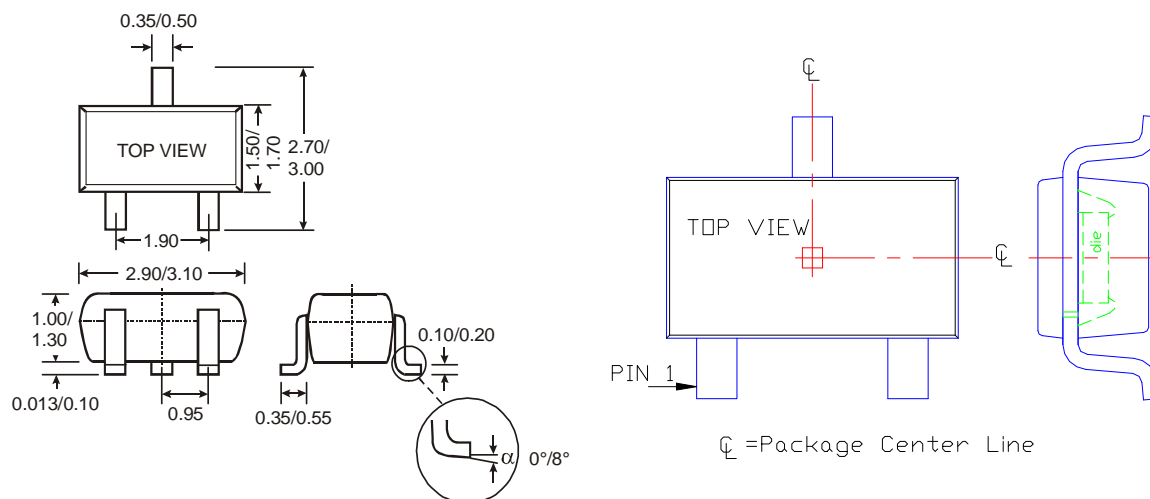

IMPORTANT NOTICE

Diodes Incorporated and its subsidiaries reserve the right to make modifications, enhancements, improvements, corrections or other changes without further notice to any product herein. Diodes Incorporated does not assume any liability arising out of the application or use of any product described herein; neither does it convey any license under its patent rights, nor the rights of others. The user of products in such applications shall assume all risks of such use and will agree to hold Diodes Incorporated and all the companies whose products are represented on our website, harmless against all damages.

LIFE SUPPORT

Diodes Incorporated products are not authorized for use as critical components in life support devices or systems without the expressed written approval of the President of Diodes Incorporated.