

Description

The AP8803 is a step-down DC/DC converter designed to drive LEDs with a constant current. The device can drive up to 7 LEDs, depending on the forward voltage of the LEDs, in series from a voltage source of 8V to 30V. Series connection of the LEDs provides identical LED currents resulting in uniform brightness and eliminating the need for ballast resistors. The AP8803 switches at frequency up to 700kHz. This allows the use of small size external components, hence minimizing the PCB area needed.

Maximum output current of AP8803 is set via an external resistor connected between the V_{IN} and SET input pins. Dimming is achieved by applying either a DC voltage or a PWM signal at the CTRL input pin. An input voltage of 0.2V or lower at CTRL shuts down the output at SW and puts the device into a low-current standby state.

Pin Assignments

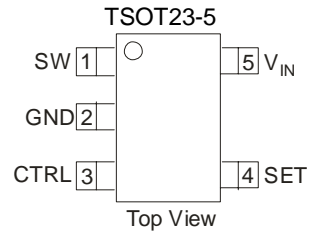

Features

- LED driving current up to 1A
- High efficiency up to 92%
- Operating input voltage up to 30V
- High switching frequency up to 700kHz
- PWM/DC input for dimming control
- Built-in output open-circuit protection
- TSOT23-5 is available in "Green" Mold Compound (No Br, Sb) and lead Free Finish/RoHS Compliant (Note 1)

Notes: 1. EU Directive 2002/95/EC (RoHS). All applicable RoHS exemptions applied. Please visit our website at http://www.diodes.com/products/lead_free.html.

Typical Application Circuit

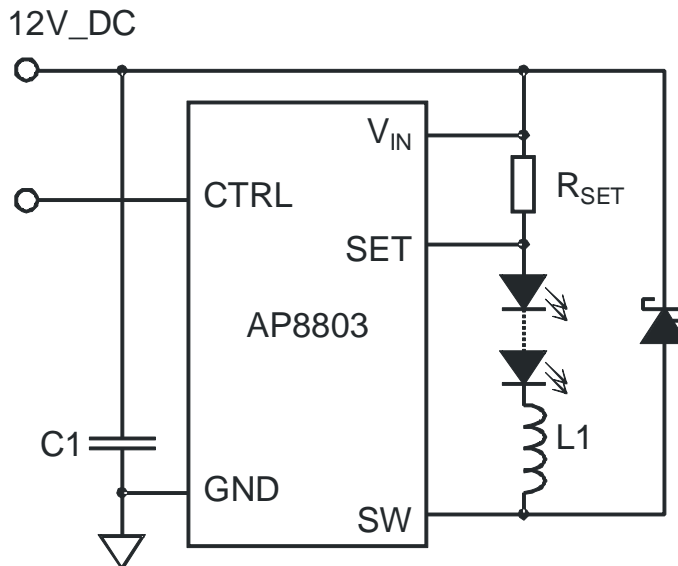

Figure 1: Typical Application Circuit

Pin Descriptions

Pin Name	Description
SW	Switch Pin. Connect inductor/freewheeling diode here, minimizing track length at this pin to reduce EMI.
GND	GND pin
SET	Set Nominal Output Current Pin. Configure the output current of the device.
CTRL	Dimming and On/Off Control Input. <ul style="list-style-type: none"> Leave floating for normal operation. ($V_{CTRL} = V_{REF} = 1.25V$ giving nominal average output current $I_{OUTnom} = 0.1/R_S$) Drive to voltage below 0.2V to turn off output current Drive with DC voltage ($0.3V < V_{CTRL} < 1.25V$) to adjust output current from 25% to 100% of I_{OUTnom} Input voltage of 0.2V or lower forces the device into low current standby mode and shuts off the output. A PWM signal allows the output current to be adjusted above or below the level set by the resistor connected to SET input pin.
V_{IN}	Input Supply Pin. Must be locally decoupled to GND with $\geq 2.2\mu F$ X7R ceramic capacitor.

Absolute Maximum Ratings

Symbol	Parameter	Rating	Unit
V_{IN}	Continuous V_{IN} pin voltage	-0.3~30	V
	Transient ($t < 0.5s$)	40	
V_{SW}	SW voltage	-0.3~30	V
	Transient ($t < 0.5s$)	40	
V_{CTRL}	CTRL pin input voltage	-0.3 ~ 6	V
I_{SW}	Switch current	1.25	A
T_J	Junction Temperature	150	°C
T_{LEAD}	Lead Temperature Soldering	300	°C
T_{ST}	Storage Temperature Range	-65 to +150	°C

Caution: The absolute maximum ratings are rated values exceeding which the product could suffer physical damage. These values must therefore not be exceeded under any condition.
Semiconductor devices are ESD sensitive and may be damaged by exposure to ESD events. Suitable ESD precautions should be taken when handling and transporting these devices

Recommended Operating Conditions

Symbol	Parameter	Min	Max	Unit
V_{IN}	Operating Input Voltage	8.0	30	V
V_{CTRLH}	Voltage High	0.3	2.5	V
V_{CTRLLL}	Voltage Low		0.25	V
T_A	Ambient Temperature Range	-40	105	°C

Electrical Characteristics ($V_{IN} = 12V$, $T_A = 25^\circ C$, unless otherwise specified.)

Symbol	Parameter	Conditions	Min	Typ.	Max	Unit
V_{INSU}	Internal regulator start up threshold	V_{IN} rising		5.65		V
V_{INSD}	Internal regulator shutdown threshold	V_{IN} falling		5.55		V
I_Q	Quiescent Current	CTRL pin floating $f = 250kHz$		1.8	5	mA
V_{THD}	Internal Threshold Voltage		92	100	108	mV
I_{SET}	SET pin input current	$V_{SET} = V_{IN} - 0.1$		1.25	10	μA
V_{REF}	Internal Reference Voltage			1.25		V
$R_{DS(on)}$	On Resistance of MOSFET	$I_{SW} = 1A$		0.5	1	Ω
I_{SW}	Continuous switch current	(Note 2)			1	A
$I_{SW_Leakage}$	Switch leakage current				8	μA
f_{OSC}	Switching Frequency				0.7	MHz
θ_{JA}	Thermal Resistance Junction-to-Ambient	TSOT23-5 (Note 3)		125		$^\circ C/W$

Notes: 2. Refer to figure 7 for the device derating curve.
 3. Test condition for SOT23-5: Device mounted on FR-4 PCB, 2"x2", 2oz copper, minimum recommended pad layout on top layer and thermal vias to bottom layer ground plane. For better thermal performance, larger copper pad for heat-sink is needed.

Applications Information

LED Current Control

The LED current is controlled by the resistor R_{SET} in Figure 1. Connected between V_{IN} and SET the nominal average output current in the LED(s) is defined as:

$$I_{LED} = \frac{V_{THD}}{R_{SET}}$$

If the CTRL pin is driven by an external voltage (lower than 2.5V), the average LED current is:

$$I_{LED} = \frac{V_{CTRL}}{V_{REF}} \frac{V_{THD}}{R_{SET}}$$

The graph in figure 2 gives values of nominal average output current for several values of current setting resistor (R_{SET}) in the typical application circuit shown on Figure 1, for different voltages applied on the CTRL pin. It can be used to determine the R_{SET} value based on the desired LED current and the condition of the CTRL pin (floating or driven with an external DC voltage lower than 2.5V and higher than 0.2V).

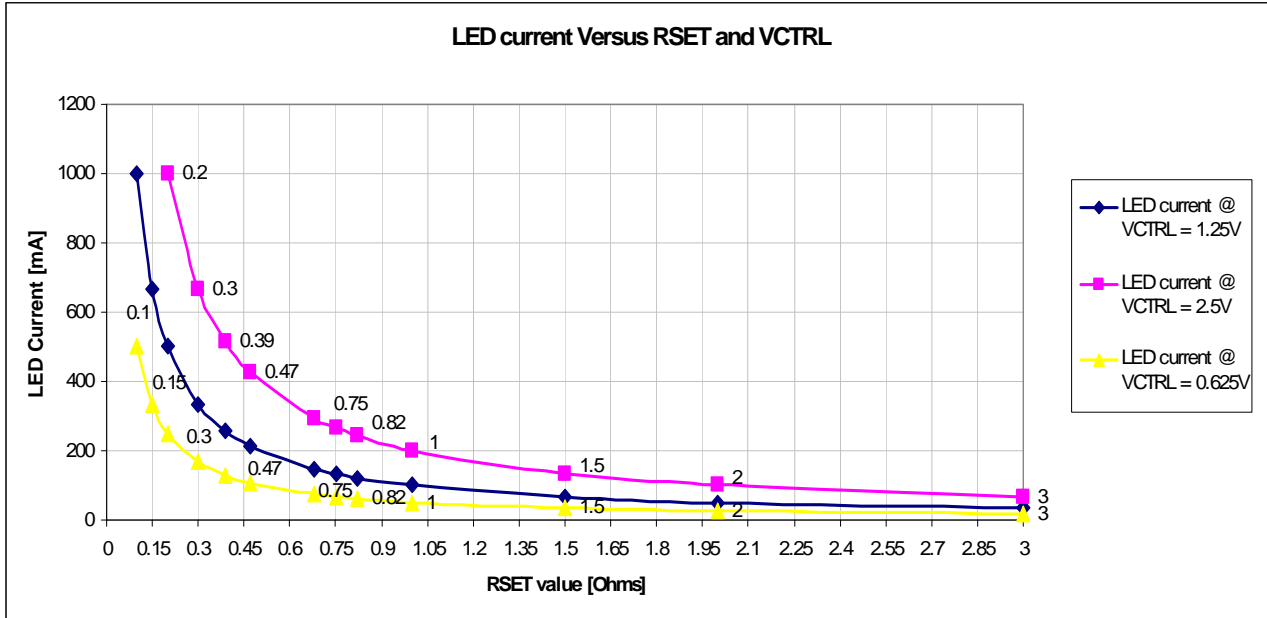

Figure 2: LED Current setting Vs RSET and VCTRL

Inductor Selection

A 33µH inductor (or higher) is recommended for most AP8803 applications with input voltage at 24V.

Figure 3 displays the resulting switching frequency varying the main circuit parameters: Supply voltage, inductor value and number of LEDs to be driven.

In particular, the graph in figure 3 gives values of nominal switching frequency for several values of inductors (L1) in the typical application circuit shown on Figure 1, for different input voltages and load condition. It can be used to determine the inductor value based on the desired switching frequency and the input and load conditions.

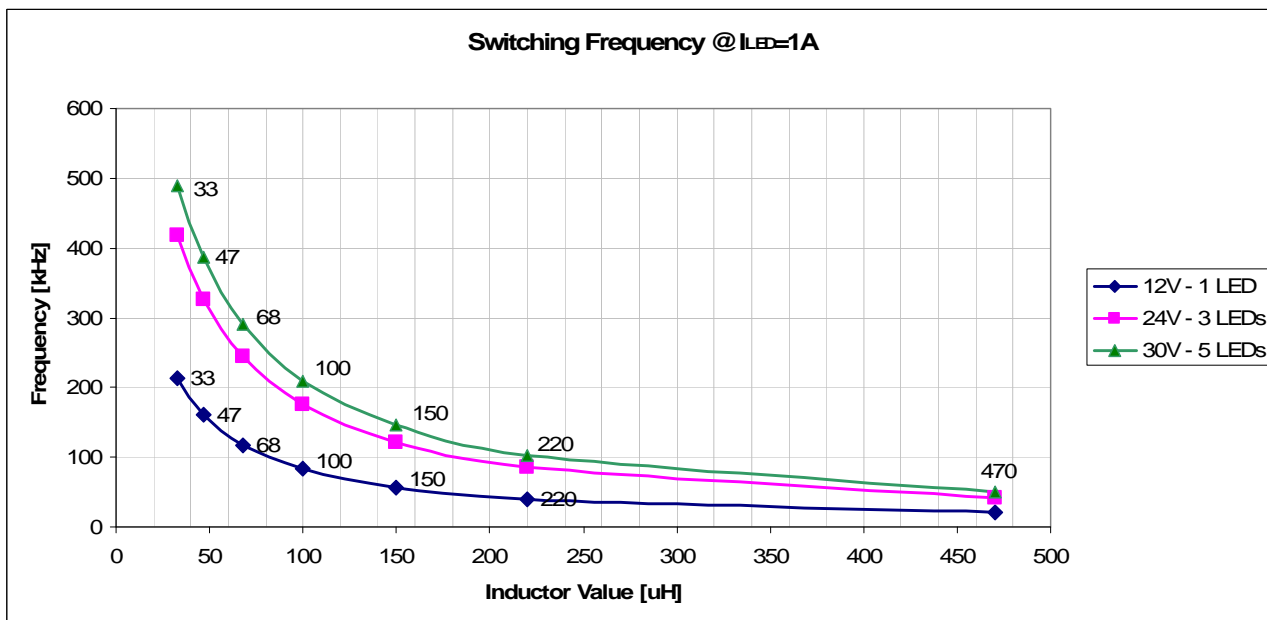

Figure 3: Switching Frequency vs. Supply voltage, Inductor, and number of LEDs

Capacitor Selection

The small size of ceramic capacitors makes them ideal for AP8803 applications. X5R and X7R types are recommended because they retain their capacitance over wider voltage and temperature ranges than other types such as Z5U. A 2.2 μ F input capacitor is sufficient for most intended applications of AP8803.

Diode Selection

Schottky diodes, e.g. B240 or DFLS240L in the proprietary PowerDI@123 package, with their low forward voltage drop and fast reverse recovery, are the ideal choice for AP8803 applications.

In addition, Super Barrier Rectifier devices (as SBR2A40P1) can be used for their enhanced thermal performances.

PWM Dimming

A Pulse Width Modulated (PWM) signal with a max resolution of 8bit, can be applied to the CTRL pin to change the output current to a value above or below the nominal average value set by resistor R_{SET} . To achieve this resolution the PWM frequency has to be lower than 500Hz.

The recommended method of driving the CTRL pin and controlling the amplitude of the PWM waveform is to use a small NPN switching transistor as shown below:

Thermal Considerations

The graph below in figure ?, gives details for power derating. This assumes the device to be mounted on a 25x25mm PCB with 1oz copper standing in still air.

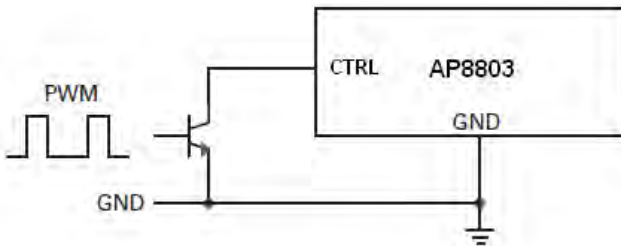

This scheme uses the 200k resistor between the CTRL pin and the internal voltage reference as a pull-up resistor for the external transistor eg MMBT3904.

Thermal Considerations

The graph below in figure 4, gives details for power derating. This assumes the device to be mounted on a 25x25mm PCB with 1oz copper standing in still air.

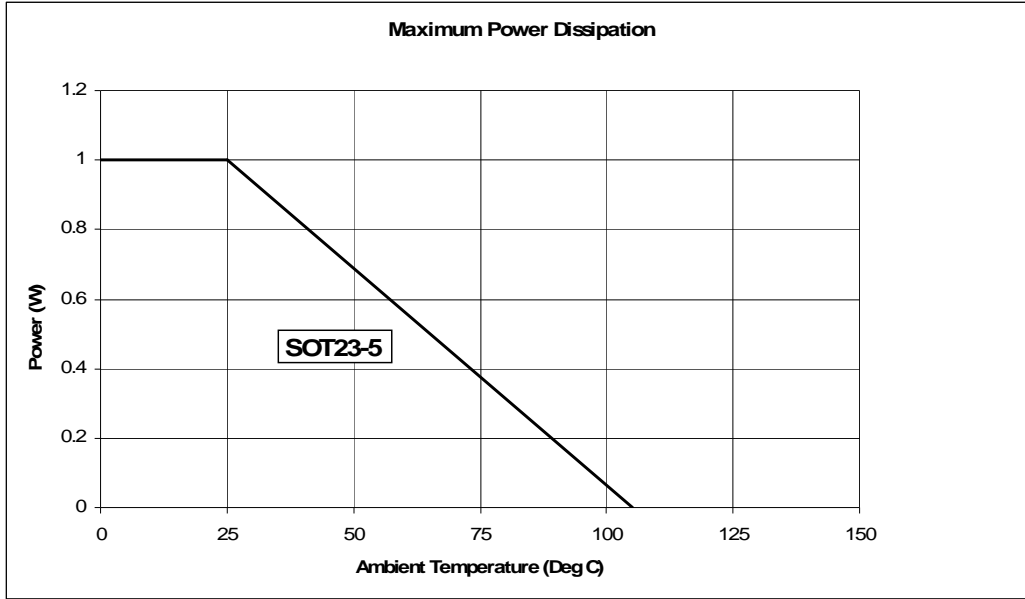
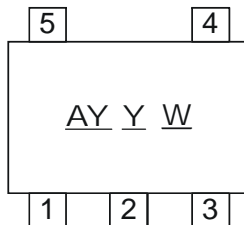

Figure 4: Derating curve

Ordering Information

Device	Package Code	Packaging (Note 2)	7"/13" Tape and Reel	
			Quantity	Part Number Suffix
AP8803WTG-7	WT	TSOT23-5	3000/Tape & Reel	-7

Marking Information



AY : Identification Code
 Y : Year 0~9
 W : Week: A~Z: 1~26 week
 a~z: 27~52 week;
 z represents 52 and 53 week

Package Outline Dimensions

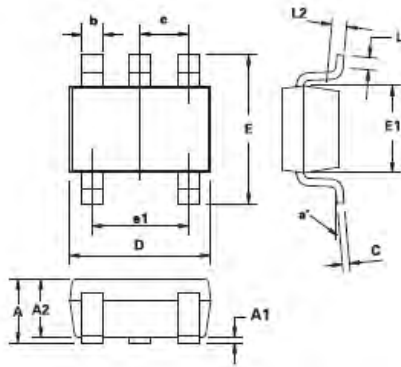

DIM	Millimeters		Inches	
	Min.	Max.	Min.	Max.
A	-	1.00	-	0.0393
A1	0.01	0.10	0.0003	0.0039
A2	0.84	0.90	0.0330	0.0354
b	0.30	0.45	0.0118	0.0177
c	0.12	0.20	0.0047	0.0078
D	2.90 BSC		0.114 BSC	
E	2.80 BSC		0.110 BSC	
E1	1.60 BSC		0.062 BSC	
e	0.95 BSC		0.0374 BSC	
e1	1.90 BSC		0.0748 BSC	
L	0.30	0.50	0.0118	0.0196
L2	0.25 BSC		0.010 BSC	
a°	4°	12°	4°	12°

Note: Controlling dimensions are in millimeters. Approximate dimensions are provided in inches

IMPORTANT NOTICE

DIODES INCORPORATED MAKES NO WARRANTY OF ANY KIND, EXPRESS OR IMPLIED, WITH REGARDS TO THIS DOCUMENT, INCLUDING, BUT NOT LIMITED TO, THE IMPLIED WARRANTIES OF MERCHANTABILITY AND FITNESS FOR A PARTICULAR PURPOSE (AND THEIR EQUIVALENTS UNDER THE LAWS OF ANY JURISDICTION).

Diodes Incorporated and its subsidiaries reserve the right to make modifications, enhancements, improvements, corrections or other changes without further notice to this document and any product described herein. Diodes Incorporated does not assume any liability arising out of the application or use of this document or any product described herein; neither does Diodes Incorporated convey any license under its patent or trademark rights, nor the rights of others. Any Customer or user of this document or products described herein in such applications shall assume all risks of such use and will agree to hold Diodes Incorporated and all the companies whose products are represented on Diodes Incorporated website, harmless against all damages.

Diodes Incorporated does not warrant or accept any liability whatsoever in respect of any products purchased through unauthorized sales channel. Should Customers purchase or use Diodes Incorporated products for any unintended or unauthorized application, Customers shall indemnify and hold Diodes Incorporated and its representatives harmless against all claims, damages, expenses, and attorney fees arising out of, directly or indirectly, any claim of personal injury or death associated with such unintended or unauthorized application.

Products described herein may be covered by one or more United States, international or foreign patents pending. Product names and markings noted herein may also be covered by one or more United States, international or foreign trademarks.

LIFE SUPPORT

Diodes Incorporated products are specifically not authorized for use as critical components in life support devices or systems without the express written approval of the Chief Executive Officer of Diodes Incorporated. As used herein:

A. Life support devices or systems are devices or systems which:

1. are intended to implant into the body, or
2. support or sustain life and whose failure to perform when properly used in accordance with instructions for use provided in the labeling can be reasonably expected to result in significant injury to the user.

B. A critical component is any component in a life support device or system whose failure to perform can be reasonably expected to cause the failure of the life support device or to affect its safety or effectiveness.

Customers represent that they have all necessary expertise in the safety and regulatory ramifications of their life support devices or systems, and acknowledge and agree that they are solely responsible for all legal, regulatory and safety-related requirements concerning their products and any use of Diodes Incorporated products in such safety-critical, life support devices or systems, notwithstanding any devices- or systems-related information or support that may be provided by Diodes Incorporated. Further, Customers must fully indemnify Diodes Incorporated and its representatives against any damages arising out of the use of Diodes Incorporated products in such safety-critical, life support devices or systems.

Copyright © 2009, Diodes Incorporated

www.diodes.com