



## **Reference Design**

# **AL9910EV8 Non-Dimmable 120V<sub>AC</sub> Evaluation Board**

**Case #1:  
(Input=120V<sub>AC</sub>; Output=48V/90mA)**

**Case #2:  
(Input=120V<sub>AC</sub>; Output=96V/45mA)**

**Applications: B10 Light Bulbs**

**-Customer: Cree-**

Date: October 27, 2011

This document contains Diodes confidential and proprietary information

## Table of Contents

1. PURPOSE .....	3
2. EVALUATION BOARD INFORMATION .....	4
2.1 AL9910 Pin Assignment and Description .....	4
2.2 Evaluation Board Schematic.....	5
2.3 Evaluation Board BOM List.....	6
2.4 Evaluation Board Layouts.....	8
2.5 Evaluation Board Snapshots .....	9
3. LED OUTPUT .....	10
4. EVALUATION BOARD TESTING SUMMARY .....	11
4.1 Testing Results (case #1):.....	11
4.2 Testing Results (case #2):.....	12
5. CONCLUSION.....	13

## 1. PURPOSE

### Introduction

We are using our AL9910 Non-Dimmable board to evaluate two test condition requirements using high-power LEDs from Cree for functional performance.

- 1) Test condition requirement #1: VIN=120VAC; OUT=48V/90mA.
- 2) Test condition requirement #2: VIN=120VAC; OUT=96V/45mA.

Customer: **Cree**

### Features

- Non-Dimmable
- Selectable 5W-8W output power
- Active PFC with power factor >0.9
- No electrolytic capacitor
- High temperature operation
- Long operating life
- Typical Applications: Retrofit E27 LED Light Bulbs

### Specifications

Parameter	Units	Value
AC Input Voltage	V, AC	90 - 140
DC Output Voltage	V, DC	40 – 98
Output Current	mA	45 - 90
Output Power	W	3 – 6
Power Factor	NA	>0.9
Efficiency	%	87%-90%
Operating Ambient temperature	C	-40 to +85
Operating Junction Temperature	C	-40 to +125
ROHS Compliance	NA	Yes

### Test conditions:

Input Voltage: 120VAC, 60Hz  
 Output Voltage: 40VDC - 98VDC  
 Operating Ambient Temperature: -40°C to 85°C

### Connection Instructions:

AC+ Input: Red – Hot  
 AC- Input: Black - Neutral  
 DC LED+ Output: LED+ (Red)  
 DC LED- Output: LED- (Black)

### Board Dimension (components included):

WxLxH (in mm) = 18mm x 25mm x 13mm

## 2. EVALUATION BOARD INFORMATION

### 2.1 AL9910 Pin Assignment and Description

---

#### AL9910 Pin Assignment

---

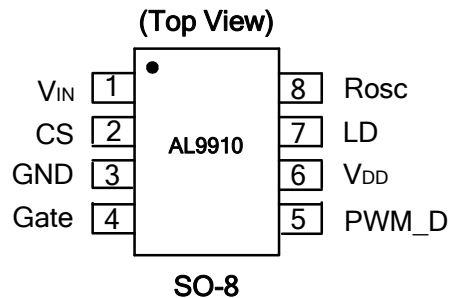

---

#### AL9910 Pin Description

---

Pin Name	Pin Number	Description
V <sub>IN</sub>	1	Input voltage
CS	2	Senses LED string current
GND	3	Device ground
Gate	4	Drives the gate of the external MOSFET
PWM_D	5	Low Frequency PWM Dimming pin, also Enable input. Internal 100kΩ pull-down to GND
V <sub>DD</sub>	6	Internally regulated supply voltage. 7.5V nominal for AL9910. Can supply up to 1 mA for external circuitry. A sufficient storage capacitor is used to provide storage when the rectified AC input is near the zero crossings
LD	7	Linear Dimming by changing the current limit threshold at current sense comparator
R <sub>OSC</sub>	8	Oscillator control. A resistor connected between this pin and ground sets the PWM frequency.

## 2.2 Evaluation Board Schematic

2.1.1 Case #1 => Test conditions:  $V_{IN}=120V_{AC}$ ;  $OUT=48V/90mA$

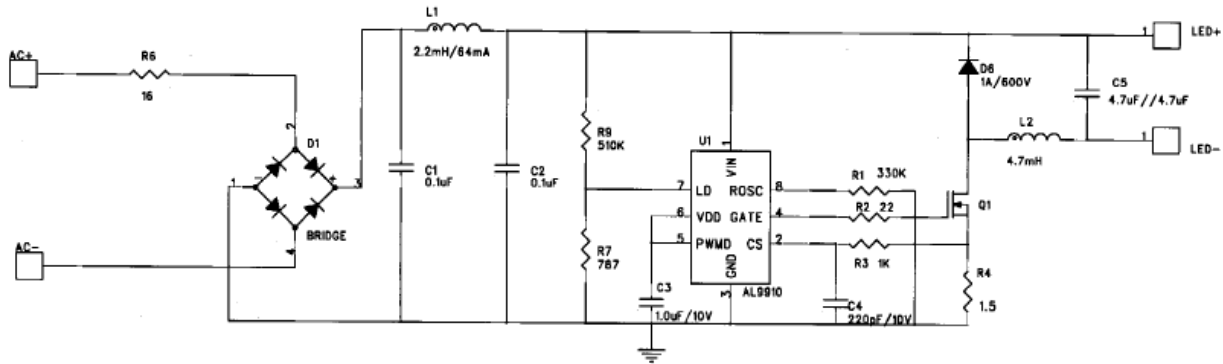

Figure 1: Evaluation Board Schematic (Case#1)

2.1.2 Case #2 => Test conditions:  $V_{IN}=120V_{AC}$ ;  $OUT=96V/45mA$

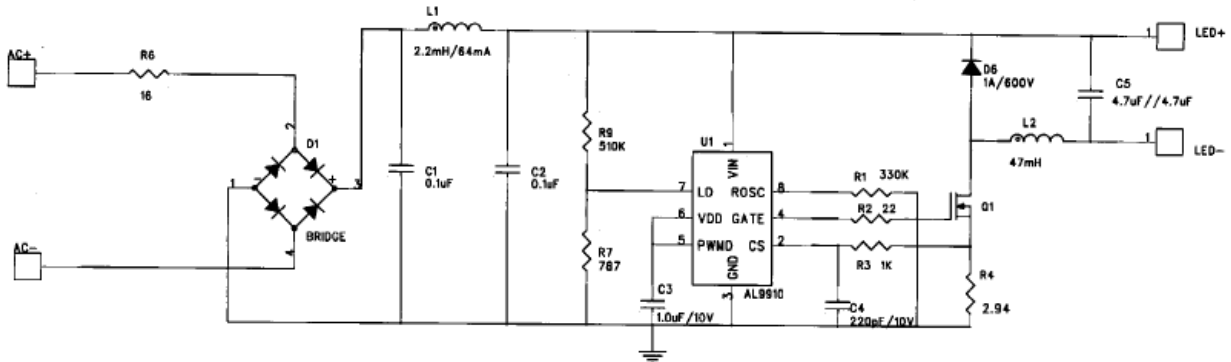

Figure 2: Evaluation Board Schematic (Case#2)

### 2.3 Evaluation Board BOM List

Case #1 => Test conditions: V <sub>IN</sub> =120V <sub>AC</sub> ; OUT=48V/90mA					
#	Name	Quantity	Part number	Manufacturer	Description
1	U1	1	AL9910S-13	Diodes	Universal High Voltage LED Driver
2	D1,2,3,4	1	HD02-T	Diodes	RECT BRIDGE GP 200V 0.8A MINIDIP
3	D6	1	MUR160-T	Diodes	DIODE ULTRA FAST 1A 600V DO-41
4	Q1	1	STD7NK40ZT4	ST	MOSFET N-CH 400V 5.4A DPAK
5	C4	1	C0402X7R1A221K	Vishay	CAP CER 220PF 10V X7R 01005
6	C3	1	C1608X7R1A105K	TDK	CAP CER 1.0UF 10V X7R 0603
7	R1	1	CRCW0402330KFKTD	Vishay	RES 330K OHM 1/16W 1% 0402 SMD
8	R3	1	CRCW04021K00FKED	Vishay	RES 1.0K OHM 1/16W 1% 0402 SMD
9	R2	1	CRCW040222R0FKED	Vishay	RES 22.0 OHM 1/16W 1% 0402 SMD
10	R4	1		Vishay	RES 1.5 OHM 1/8W 1% 0805 SMD
11	R6	1	CRCW120616R0FKEA	Vishay	RES 16.0 OHM 1/4W 1% 1206 SMD
12	R9	1	CRCW1206510KJNEA	Vishay	RES 510K OHM 1/4W 5% 1206 SMD
13	R7	1	CRCW0402787RFKED	Vishay	RES 787 OHM 1/16W 1% 0402 SMD
14	C1, C2	2	VJ1812Y104KXETW1BC	Vishay	CAP Multilayer Cer (MLCC) – SMD / SMT 1812 0.1uF 500volts X7R 10%
16	C5	2	UMK325C7106MM-T	Taiyo	CAP CER 4.7uF//4.7uF 100V X7R 1210
16	L1	1	LPS5015-225ML	Coilcraft	Inductor 2.2mH 64mA
17	L2	1	13R475C	Murata	Inductor Radial 4.7mH 0.16A

Case #2 => Test conditions:  $V_{IN}=120V_{AC}$ ;  $OUT=96V/45mA$ 

#	Name	Quantity	Part number	Manufacturer	Description
1	U1	1	AL9910S-13	Diodes	Universal High Voltage LED Driver
2	D1,2,3,4	1	HD02-T	Diodes	RECT BRIDGE GP 200V 0.8A MINIDIP
3	D6	1	MUR160-T	Diodes	DIODE ULTRA FAST 1A 600V DO-41
4	Q1	1	STD7NK40ZT4	ST	MOSFET N-CH 400V 5.4A DPAK
5	C4	1	C0402X7R1A221K	Vishay	CAP CER 220PF 10V X7R 01005
6	C3	1	C1608X7R1A105K	TDK	CAP CER 1.0UF 10V X7R 0603
7	R1	1	CRCW0402330KFKTD	Vishay	RES 330K OHM 1/16W 1% 0402 SMD
8	R3	1	CRCW04021K00FKED	Vishay	RES 1.0K OHM 1/16W 1% 0402 SMD
9	R2	1	CRCW040222R0FKED	Vishay	RES 22.0 OHM 1/16W 1% 0402 SMD
10	R4	1	CRCW08052R94FKEA	Vishay	RES 2.94 OHM 1/8W 1% 0805 SMD
11	R6	1	CRCW120616R0FKEA	Vishay	RES 16.0 OHM 1/4W 1% 1206 SMD
12	R9	1	CRCW1206510KJNEA	Vishay	RES 510K OHM 1/4W 5% 1206 SMD
13	R7	1	CRCW0402787RFKED	Vishay	RES 787 OHM 1/16W 1% 0402 SMD
14	C1, C2	2	VJ1812Y104KXETW1BC	Vishay	CAP Multilayer Cer (MLCC) – SMD / SMT 1812 0.1uF 500volts X7R 10%
16	C5	2	C3225X7S2A475K	TDK	CAP CER 4.7uF//4.7uF 100V 1210
16	L1	1	LPS5015-225ML	Coilcraft	Inductor 2.2mH 64mA
17	L2	1	13R476C	Murata	Inductor Radial 47mH 0.045A

2.4 Evaluation Board Layouts

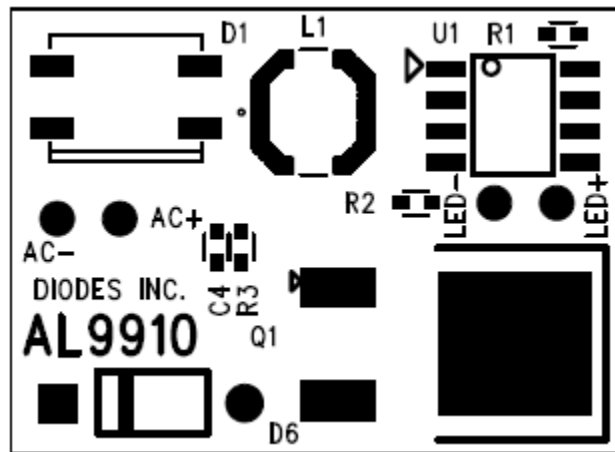

Figure 3: Top-View PCB Layout

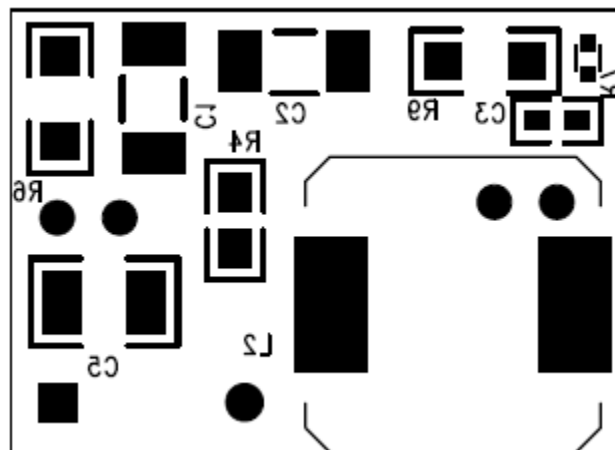

Figure 4: Bottom-View PCB Layout

## 2.5 Evaluation Board Snapshots

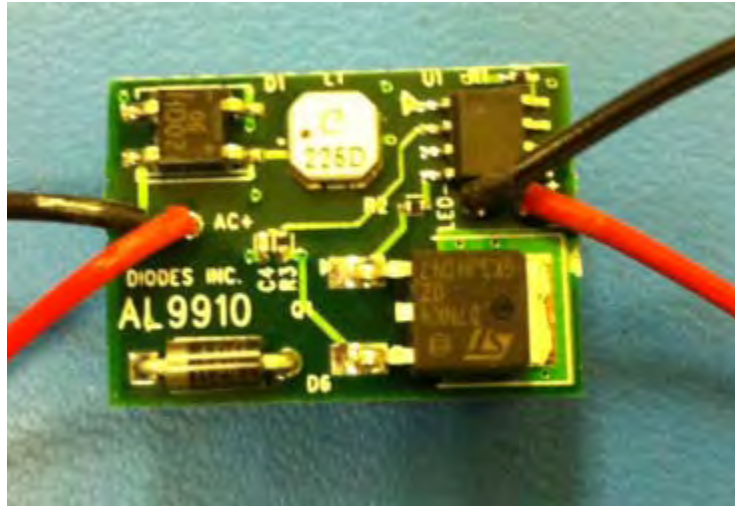

Figure 5: Top-View PCB Board

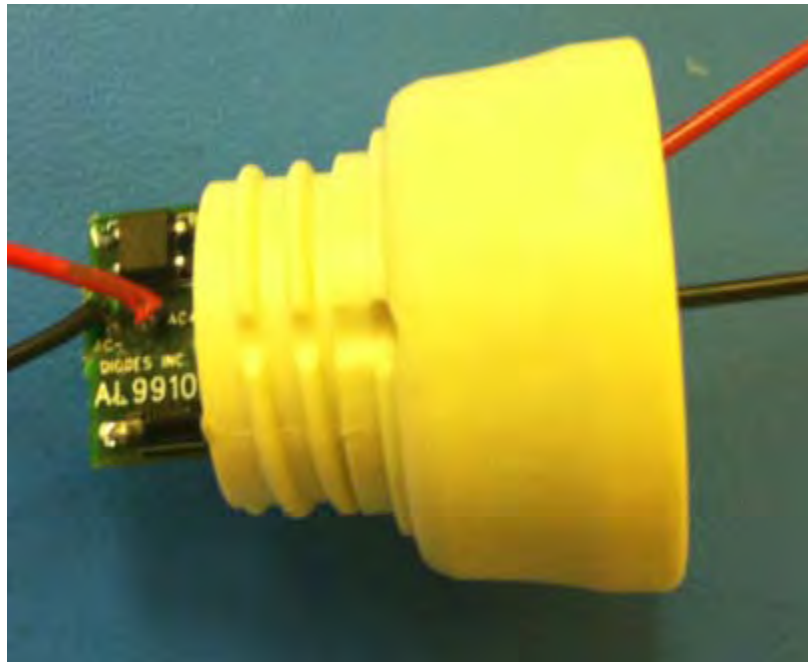

Figure 6: Top-View PCB Board in Bulb Module

### 3. LED OUTPUT

- 3.1 LED P/N: Cree XM-L T6  
LED Output: ~+48V (ideal)



- 3.2 LED P/N: Cree XPSTAR103  
LED Output: ~+96V (ideal)

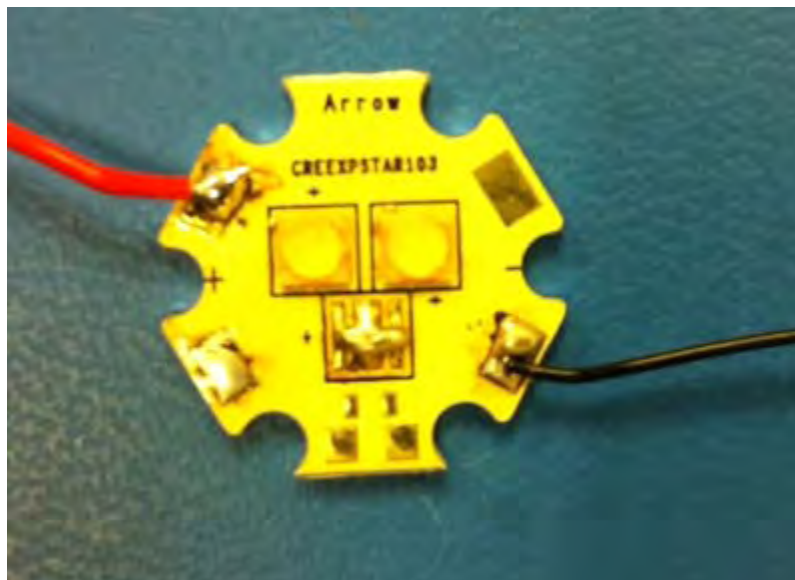

#### 4. EVALUATION BOARD TESTING SUMMARY

##### 4.1 Testing Results (case #1):

(Case #1 => Test conditions:  $V_{IN}=120V_{AC}$ ;  $OUT=48V/90mA$ ):

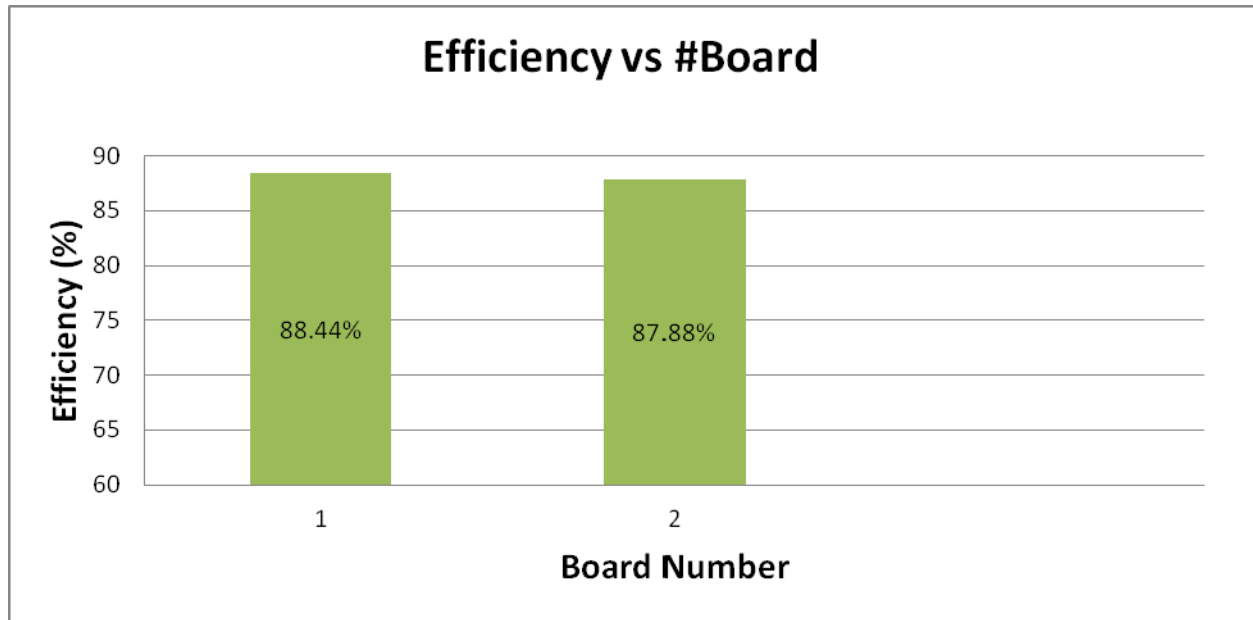

(Case #1 => Test conditions:  $V_{IN}=120V_{AC}$ ;  $OUT=48V/90mA$ ):

Board #	Cree LED	$V_{RMS}$ (V)	$I_{RMS}$ (mA)	$P_{IN}$ (W)	PFC	$V_{LED}$ (V)	$I_{LED}$ (mA)	$P_{OUT}$ (W)	Efficiency (%)
1	48V	120.52	34.45	4.032	0.969	41.35	91.14	3.566	88.44
2	48V	120.62	35.32	4.125	0.966	41.4	91.95	3.625	87.88

**4.2 Testing Results (case #2):**

(Case #2 => Test conditions: V<sub>IN</sub>=120V<sub>AC</sub>; OUT=96V/45mA):

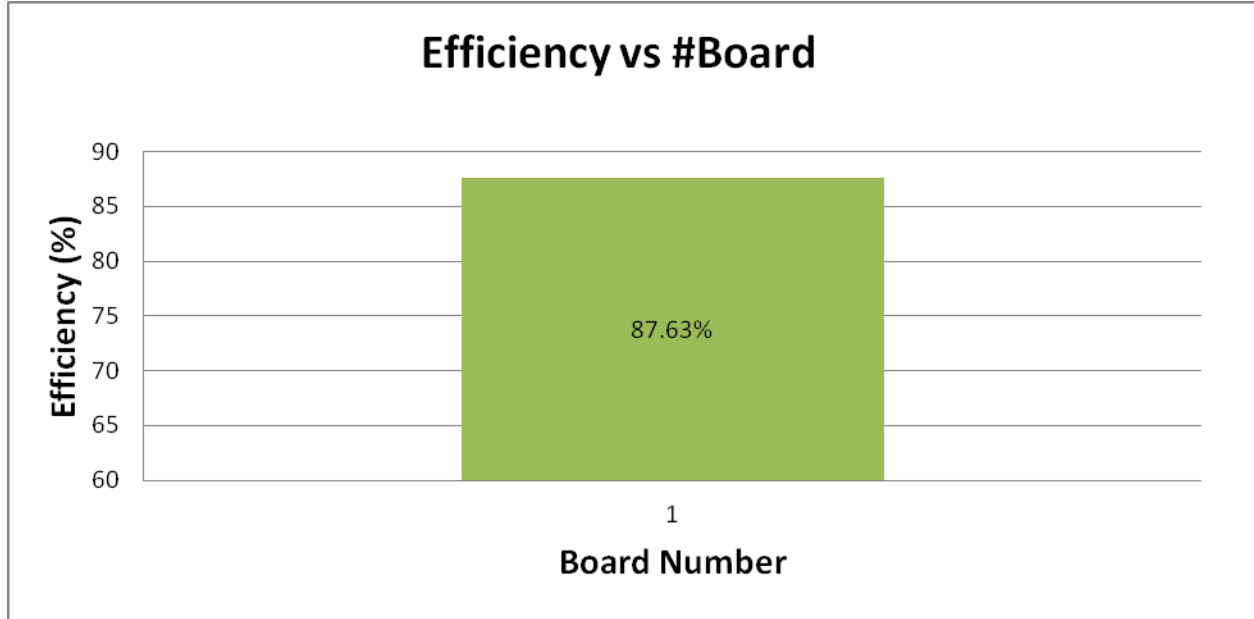

(Case #2 => Test conditions: V<sub>IN</sub>=120V<sub>AC</sub>; OUT=96V/45mA):

Board #	Cree LED	V <sub>RMS</sub> (V)	I <sub>RMS</sub> (mA)	P <sub>IN</sub> (W)	PFC	V <sub>LED</sub> (V)	I <sub>LED</sub> (mA)	P <sub>OUT</sub> (W)	Efficiency (%)
1	96	120.02	37.03	4.227	0.962	94.43	46.17	3.704	87.63

## 5. CONCLUSION

It is concluded that the new circuit implementation of replacing the inductor (L2) and changing the R<sub>SENSE</sub> (R4) fully function as expected. As configured in a high-power 48V LED module, the efficiency is about ~88% and PFC is ~0.969. As configured in a high-power 96V LED module, the efficiency is about ~87.6% and PFC is ~0.962.

Main benefits are achieved in the high-power LED evaluation:

- 1) High Efficiency
- 2) High PFC (>0.9)
- 3) No electrolytic capacitor
- 4) Correct average LED output current
- 5) Suitable for E27 LED Light Bulbs

**IMPORTANT NOTICE**

DIODES INCORPORATED MAKES NO WARRANTY OF ANY KIND, EXPRESS OR IMPLIED, WITH REGARDS TO THIS DOCUMENT, INCLUDING, BUT NOT LIMITED TO, THE IMPLIED WARRANTIES OF MERCHANTABILITY AND FITNESS FOR A PARTICULAR PURPOSE (AND THEIR EQUIVALENTS UNDER THE LAWS OF ANY JURISDICTION).

Diodes Incorporated and its subsidiaries reserve the right to make modifications, enhancements, improvements, corrections or other changes without further notice to this document and any product described herein. Diodes Incorporated does not assume any liability arising out of the application or use of this document or any product described herein; neither does Diodes Incorporated convey any license under its patent or trademark rights, nor the rights of others. Any Customer or user of this document or products described herein in such applications shall assume all risks of such use and will agree to hold Diodes Incorporated and all the companies whose products are represented on Diodes Incorporated website, harmless against all damages.

Diodes Incorporated does not warrant or accept any liability whatsoever in respect of any products purchased through unauthorized sales channel.

Should Customers purchase or use Diodes Incorporated products for any unintended or unauthorized application, Customers shall indemnify and hold Diodes Incorporated and its representatives harmless against all claims, damages, expenses, and attorney fees arising out of, directly or indirectly, any claim of personal injury or death associated with such unintended or unauthorized application.

Products described herein may be covered by one or more United States, international or foreign patents pending. Product names and markings noted herein may also be covered by one or more United States, international or foreign trademarks.

**LIFE SUPPORT**

Diodes Incorporated products are specifically not authorized for use as critical components in life support devices or systems without the express written approval of the Chief Executive Officer of Diodes Incorporated. As used herein:

A. Life support devices or systems are devices or systems which:

1. are intended to implant into the body, or
2. support or sustain life and whose failure to perform when properly used in accordance with instructions for use provided in the labeling can be reasonably expected to result in significant injury to the user.

B. A critical component is any component in a life support device or system whose failure to perform can be reasonably expected to cause the failure of the life support device or to affect its safety or effectiveness.

Customers represent that they have all necessary expertise in the safety and regulatory ramifications of their life support devices or systems, and acknowledge and agree that they are solely responsible for all legal, regulatory and safety-related requirements concerning their products and any use of Diodes Incorporated products in such safety-critical, life support devices or systems, notwithstanding any devices- or systems-related information or support that may be provided by Diodes Incorporated. Further, Customers must fully indemnify Diodes Incorporated and its representatives against any damages arising out of the use of Diodes Incorporated products in such safety-critical, life support devices or systems.

Copyright © 2011, Diodes Incorporated

[www.diodes.com](http://www.diodes.com)