

ZXCT1081 EV1

ZXCT1081EV1 EVALUATION BOARD USER GUIDE

DESCRIPTION

The ZXCT1081EV1 is intended for the evaluation of the ZXCT1081 device. The ZXCT1081 is a high side current monitor providing a fixed voltage gain of 10.

The device produces a voltage output proportional to the current sampled by a small inline sensing resistor, R_{sense} . The voltage output is scaled by the choice of R_{sense} .

As delivered the board is set up to provide an output of 1.5V from a current of 1.5A using a 100 m Ω sampling resistor.

There is a second (50m Ω) resistor that can be selected by means of a solder link and provides an output of 1.5V for a load current of 3A.

Additionally, provision is made for a wire ended sampling resistor of the users choice. An open collector flag output indicates the direction of current flow.

The printed circuit board is common to other devices in the ZXCT family, for the ZXCT1081, the FLAG pin is not used.

FEATURES

- Supply Range 4.2 to 40V for 1.5V output.
- Selectable current measurement range
- 5 Pin SOT23-5 package

APPLICATIONS

- Battery Charging
- Power Supplies
- Over Current Monitoring



ZXCT1081 EV1



ORDERING INFORMATION

ORDER NUMBER
ZXCT1081EV1

Please note evaluation boards are subject to availability and qualified leads.

PAD NAMES AND DEFINITIONS

NAME	DESCRIPTION
V1	Supply Voltage
V2	Connection to Load
VOUT	Output Voltage
FLAG	Not used
GND	0V / Ground
SL1,SL2	Solder Links
Vcc	Supply for the output buffer

The ZXCT1081EV1 is configured as shown in figure 1; SL1 is shorted to output 1.5V for a 1.5A current flow. The target applications are battery chargers, power supply units and other applications where current measurement is a requirement.

The input voltage range for the ZXCT1081EV1 is 40V down to a minimum of (2.7V +Vout). E.g. if the required full scale output voltage is 1.5 V the input range is 4.2V to 40V.

ZXCT1081 EV1

ZXCT1081EV1 Schematic

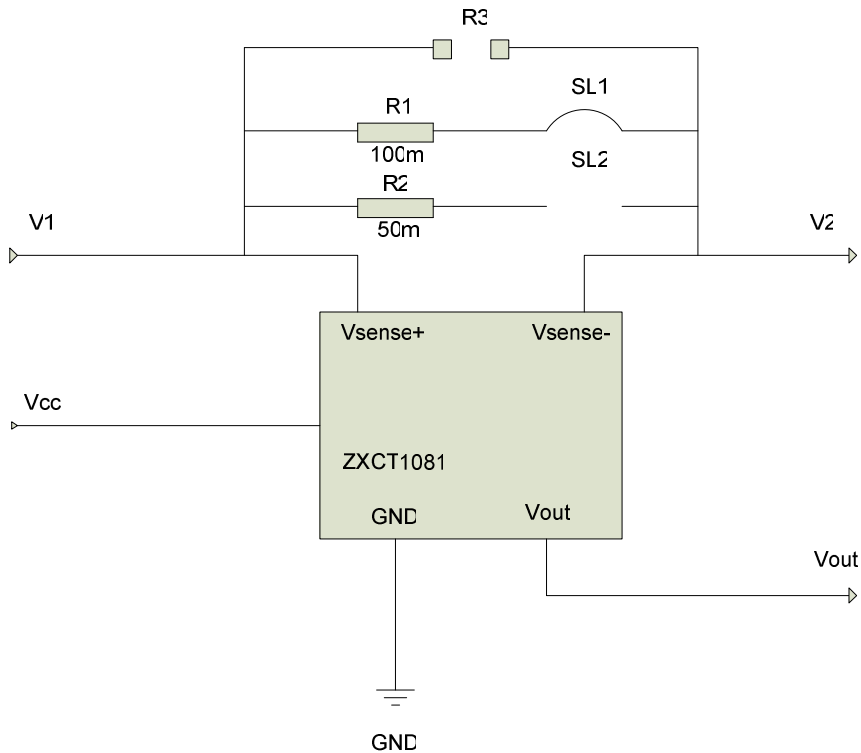

Sense resistor

The board has been designed with two selectable values of sense resistor. The value of the sense resistor can be chosen by using the solder links SL1 and SL2.

The board is also tracked for a user defined through hole resistor (R3).

The 100m Ω resistor (R1) is selected by shorting SL1 and opening SL2. This results in an output of 1.5V for a load current of 1.5A (assuming that R3 is not fitted).

The 50m Ω resistor (R2) is selected by shorting SL2 and opening SL1, resulting in an output of 1.5V for a load current of 3A (assuming that R3 is not fitted).

If both links are shorted the effective resistance is 33.33m Ω giving an output of 1.5V for a current of 4.5A (assuming that R3 is not fitted).

If both links are open only the optional leaded resistor R3 (if fitted) is in circuit.

The maximum power dissipation rating of the resistor must be appropriate to the load current level.

N.B. The board is set by default with SL1 shorted and SL2 open, using the 100m Ω resistor.

For further information on choosing a value of sense resistor please refer to the ZXCT1081 datasheet .

Vout

If the preset selectable values of sense resistor are chosen, the device will produce 1.5V for a 1.5A load current or 1.5V for a 3.0A load current, depending on which link is closed. The output is directly proportional to the differential voltage across the sense pins of the device.

ZXCT1081 EV1



Configuration table for ZXCT1081EV1

LOAD CURRENT (A)	R _{sense} (mΩ)	VOUT (V)	SOLDER LINK CONFIGURATION
1.5	100	1.5	Short SL1
3.0	50	1.5	Short SL2
4.5	33.33	1.5	Short SL1 & SL2

Vcc

The Vcc pin is the supply for Vout buffer and must be between 4.5V and 12V.

Configuration for different LOAD currents.

The board can be configured for different load currents by changing the smd resistors or fitting a suitable wire ended resistor and opening both solder links. It is important to ensure an appropriate value of R_{sense} is selected to obtain the desired accuracy for a given output current.

The value of Vout is 10 times the voltage dropped across the sensing resistor, (providing that the voltage on V1 is more than 2.7V higher than the Vout.)

Choosing a larger value for R_{sense} gives a higher output voltage for a given current resulting in better resolution but at the expense of increased voltage drop and higher dissipation in R_{sense}. It also reduces the minimum voltage at which the device will be linear as Vout +2.7V is the minimum input voltage for accurate results.

The ZXCT1081 is optimized for values of V_{sense} between 0 and 150mV but may be used up to 800mV.

Example: Scaling for 1.5A load current and a 500mV output.

The ZXCT1081 has a fixed gain of 10. $V_{out} = 10 \times V_{sense}$
To obtain a 500mV output, 50mV is required between V_{sense+} and V_{sense-}.
The value for R_{sense} is thus 50mV /1.5A = 33mΩ.

Accuracy

The ZXCT1081 current monitor IC is a 3%¹ accurate device. The accuracy of the output voltage will be influenced by the tolerance of the external sense used. The ZXCT1081EV1 utilizes 1% accurate sense resistors.

¹ Total error at +100mV sense voltage

COMPONENTS LIST

Ref	Value	Package	Part Number	Manufacturer	Notes
R1	100mΩ	1206	LR1206-R10FI	Welwyn	SMD Sense Resistor 1%
R2	50mΩ	2512	LRF2512-R050FW	Welwyn	SMD Sense Resistor 1%
ZXCT		SOT235	ZXCT1081E5	ZETEX	

ZXCT1081 EV1



SET-UP AND TEST

The board is preset to give an output Voltage of 1.5V for a load current of 1.5A (SL1 is shorted to connect in the 100mΩ (R1) sense resistor). To change the board to give an output Voltage of 1.5V for a current of 3.0A, de-solder SL1 and short SL2. This connects the 50mΩ (R2) sense resistor.

1.0 Ampere load test

1. Ensure SL1 is shorted.
2. Connect a linear power supply of +15V between the V1 and GND terminals.
3. Connect a linear power supply of +5V between the Vcc and GND terminals.
4. Set a load current of 1.5A between the V2 and GND terminals using a suitable load.

The load must be rated for at least 30W .

5. Check with a DVM the supply voltage is +15V between the V1 and GND terminals.
6. Measure VOUT with a DVM. The nominal output voltage should read 1.5V.

The device may also be evaluated with lower power loads and lower currents by increasing the value of R_{sense} . As the device reacts only to the voltage across this resistor such tests are equally valid.

CONNECTION DIAGRAM

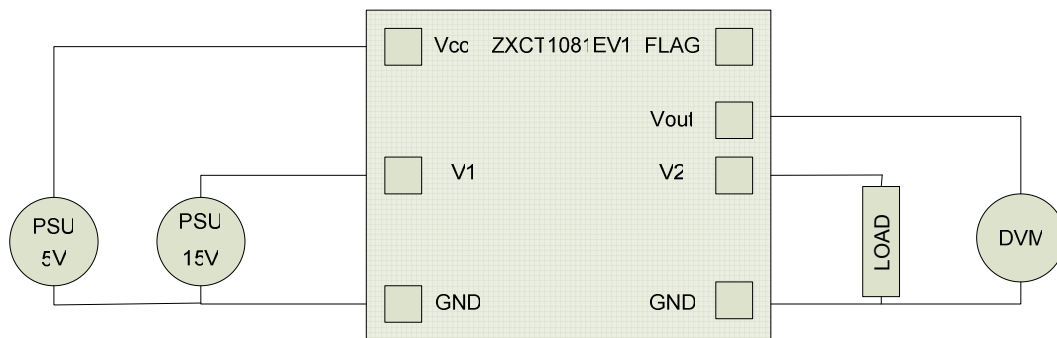

ZXCT1081 EV1



EVALUATION BOARD

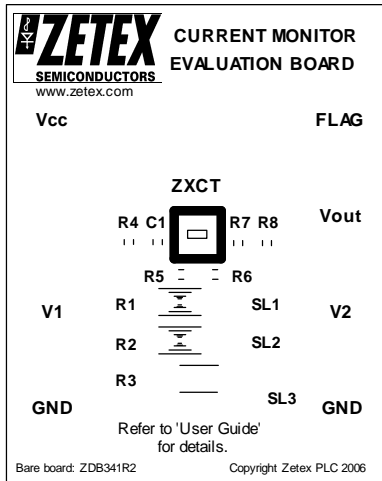

Top Silk

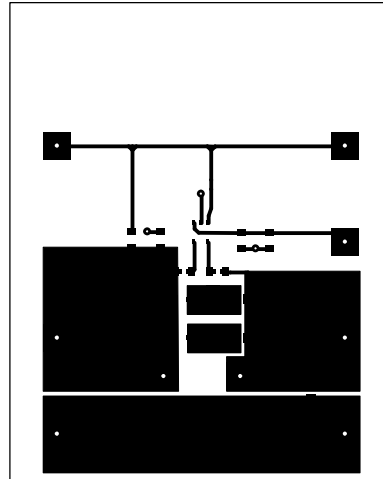

Top Copper

Definitions

Product change

Zetex Semiconductors reserves the right to alter, without notice, specifications, design, price or conditions of supply of any product or service. Customers are solely responsible for obtaining the latest relevant information before placing orders.

Applications disclaimer

The circuits in this design/application note are offered as design ideas. It is the responsibility of the user to ensure that the circuit is fit for the user's application and meets with the user's requirements. No representation or warranty is given and no liability whatsoever is assumed by Zetex with respect to the accuracy or use of such information, or infringement of patents or other intellectual property rights arising from such use or otherwise. Zetex does not assume any legal responsibility or will not be held legally liable (whether in contract, tort (including negligence), breach of statutory duty, restriction or otherwise) for any damages, loss of profit, business, contract, opportunity or consequential loss in the use of these circuit applications, under any circumstances.

Life support

Zetex products are specifically not authorized for use as critical components in life support devices or systems without the express written approval of the Chief Executive Officer of Zetex Semiconductors plc. As used herein:

- A. Life support devices or systems are devices or systems which:
1. are intended to implant into the body
- or
2. support or sustain life and whose failure to perform when properly used in accordance with instructions for use provided in the labeling can be reasonably expected to result in significant injury to the user.
- B. A critical component is any component in a life support device or system whose failure to perform can be reasonably expected to cause the failure of the life support device or to affect its safety or effectiveness.

Reproduction

The product specifications contained in this publication are issued to provide outline information only which (unless agreed by the company in writing) may not be used, applied or reproduced for any purpose or form part of any order or contract or be regarded as a representation relating to the products or services concerned.

Terms and Conditions

All products are sold subjects to Zetex' terms and conditions of sale, and this disclaimer (save in the event of a conflict between the two when the terms of the contract shall prevail) according to region, supplied at the time of order acknowledgement.

For the latest information on technology, delivery terms and conditions and prices, please contact your nearest Zetex sales office.

Quality of product

Zetex is an ISO 9001 and TS16949 certified semiconductor manufacturer.

To ensure quality of service and products we strongly advise the purchase of parts directly from Zetex Semiconductors or one of our regionally authorized distributors. For a complete listing of authorized distributors please visit: www.zetex.com/salesnetwork

Zetex Semiconductors does not warrant or accept any liability whatsoever in respect of any parts purchased through unauthorized sales channels.

ESD (Electrostatic discharge)

Semiconductor devices are susceptible to damage by ESD. Suitable precautions should be taken when handling and transporting devices. The possible damage to devices depends on the circumstances of the handling and transporting, and the nature of the device. The extent of damage can vary from immediate functional or parametric malfunction to degradation of function or performance in use over time. Devices suspected of being affected should be replaced.

Green compliance

Zetex Semiconductors is committed to environmental excellence in all aspects of its operations which includes meeting or exceeding regulatory requirements with respect to the use of hazardous substances. Numerous successful programs have been implemented to reduce the use of hazardous substances and/or emissions.

All Zetex components are compliant with the RoHS directive, and through this it is supporting its customers in their compliance with WEEE and ELV directives.

Product status key:

"Preview"	Future device intended for production at some point. Samples may be available
"Active"	Product status recommended for new designs
"Last time buy (LTB)"	Device will be discontinued and last time buy period and delivery is in effect
"Not recommended for new designs"	Device is still in production to support existing designs and production
"Obsolete"	Production has been discontinued

Datasheet status key:

"Draft version"	This term denotes a very early datasheet version and contains highly provisional information, which may change in any manner without notice.
"Provisional version"	This term denotes a pre-release datasheet. It provides a clear indication of anticipated performance. However, changes to the test conditions and specifications may occur, at any time and without notice.
"Issue"	This term denotes an issued datasheet containing finalized specifications. However, changes to specifications may occur, at any time and without notice.

Europe	Americas	Asia Pacific	Corporate Headquarters
Zetex GmbH Kustermann-park Balanstraße 59 D-81541 München Germany Telefon: (49) 89 45 49 49 0 Fax: (49) 89 45 49 49 49 europe.sales@zetex.com	Zetex Inc 700 Veterans Memorial Highway Hauppauge, NY 11788 USA Telephone: (1) 631 360 2222 Fax: (1) 631 360 8222 usa.sales@zetex.com	Zetex (Asia Ltd) 3701-04 Metroplaza Tower 1 Hing Fong Road, Kwai Fong Hong Kong Telephone: (852) 26100 611 Fax: (852) 24250 494 asia.sales@zetex.com	Zetex Semiconductors plc Zetex Technology Park, Chadderton Oldham, OL9 9LL United Kingdom Telephone (44) 161 622 4444 Fax: (44) 161 622 4446 hq@zetex.com

© 2006 Published by Zetex Semiconductors plc.