

Excessive current consumption reduction for switches with undershoot protection

By Paul Li

Pericom's Bus switch PI5C16233C has the undershoot-protection feature. This undershoot protection feature allows the switch to work even if there is an undershoot occurred at the input. This undershoot protection circuit senses the edges of signals applied to the "xA", "SELx" and "TESTx" pins, and turns on the internal undershoot protection function at the edges to prevent the switch from turning on by the undershoot when it is set off.

When the voltage at the "xA", "SELx" and "TESTx" pins are DC 5V or 0V driven by a pull-up or pull-down resistor, or when the signal at these pins are AC signals swinging between 0V to 5V, the quiescent I_{cc} current of the switch is within 200uA as specified in datasheet. A normal I_{cc} current will be observed.

But, if the "xA", "SELx" and "TESTx" pins are left floating at high Z and if there is a 1.2V to 1.5V voltage either from noise or leakage, it will trigger the undershoot protection circuit and induce a 1.0mA to 1.6mA I_{cc} current for each pin that has been triggered.

Even through this triggered I_{cc} current will not cause any damage to the PI5C16233C switch, it will add extra quiescent I_{cc} current to a maximum of 17mA through the switch. This triggered I_{cc} current will remain ON for as long as the power is on. But, if the power of the switch is turned off and held for 10 minutes or so, and then turned on again, the excessive I_{cc} current will not be present. If the power-off duration is less than 2 minutes, and then turned on again, the excess current consumption will be observed again. This phenomenon is caused by that the noise voltage is in the transition region of the internal CMOS gate. The current triggered by the noise will disappear after the gate is discharged.

Based on the above, we would recommend adding 10K to 22K pull-up or pull-down resistors (both work fine) solely at all "xA", "SELx" and "TESTx" pins (see figure 1). These resistors will ensure that the voltage at "xA", "SELx" and "TESTx" pins will not stay at 1.2V to 1.5V, but at 0V or 5V, either for a swinging signal or for the pull-up or pull-down case, therefore the pull-up/pull-down circuits will prevent the excessive I_{cc} current.

This approach is also applicable to PI5C34171C, PI5C32161C, and other switches specified in datasheets to have undershoot protection.

See Block Diagram on next page.

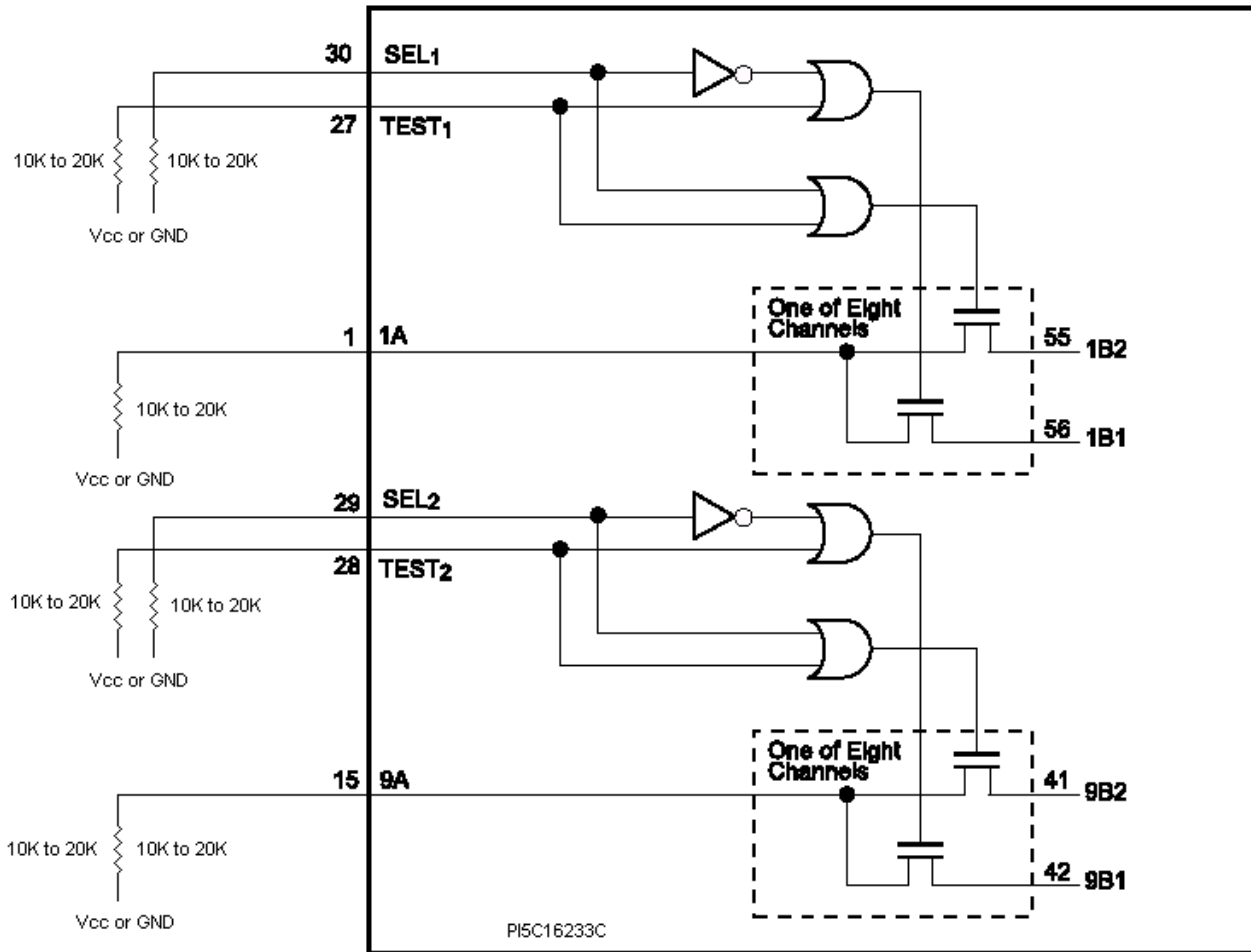

Figure 1: Pull-up or pull-down resistors for PI5C16233C