

Introduction

DMDB2101 is designed to serve as a generic power stage for BLDC and stepper motor driving. This board is designed to work with all the mainstream MCU for motor control applications. Onboard voltage regulators provide necessary voltages rails to the MCU and the hall effect sensors. DMDB2101 is designed to work with MCU using both the back-EMF control algorithm and/or hall-effect sensor input. The modular approach of the board means it can be easily integrated with different MCU boards and motor units making the development process fast and easy.

Performance

- Drive Circuit supply voltage (V_{cc}) range: 10V to 20V
- Motor voltage (V_M) range up to 60V (MOSFET limited)
- Onboard 5V and 3.3V voltage rails
- Motor current up to 5A (Fuse limited)
- Three half-bridges for three phase BLDC motor drive
- General-purpose power stage for BLDC and stepper motors
- Back-EMF, Hall sensor, Current feed back to MCU.
- Dimensions: 69mm*65mm

Ordering Information

Order Number
DMDB2101

Caution: Do not connect the evaluation board to a V_{cc} voltage of >20V & V_M voltage of >60V!

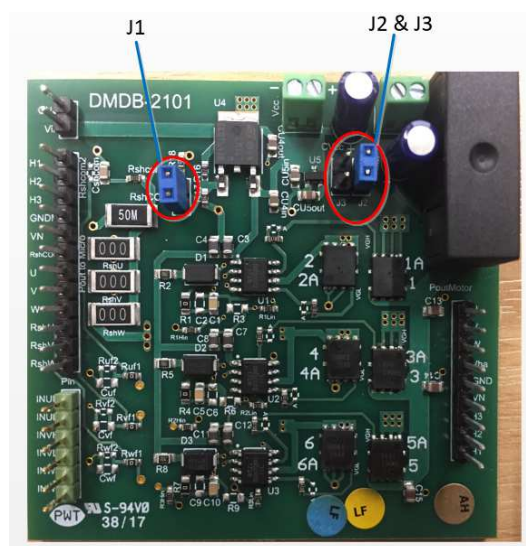

Figure 1. Evaluation board layout

Evaluation board is provided with a jumper (J1) to select the voltage (3.3V or 5V) to MCU; when J1 is connected it provides 3.3V from the regulator U4 to MCU and when not connected it provides 5V from the regulator U4 to MCU. Another jumper (J2/J3) is provided to select 5V to the hall sensors either from regulator U4 or from the regulator U5. If J1 is set to 3.3V, use J3 to provide 5V to the hall sensor and if J1 is set to 5V, use J2 to provide 5V to the hall sensor.

This application note contains new product information. Diodes, Inc. reserves the right to modify the product specification without notice. No liability is assumed as a result of the use of this product. No rights under any patent accompany the sale of the product.

Board Input-output Interface

The modular approach of the board, with 2.54mm headers, makes the integration with the MCU board and the motor easy. The MCU interface is designed on the left side of the board, the motor unit interface is designed on the right side of the board and the voltage inputs at the top of the board. Refer to figure 2.

Vin and GND:

The 2-pin header present at the top left-hand corner of the board (Figure 2), these pins can provide an adjustable, 3.3V and 5V, voltage rails to the MCU board using the jumper J1. By shorting the pins of the J1 with the provided blue bus bar 3.3V can be applied to the MCU board and by leaving the J1 pins open a 5V supply is applied to the MCU.

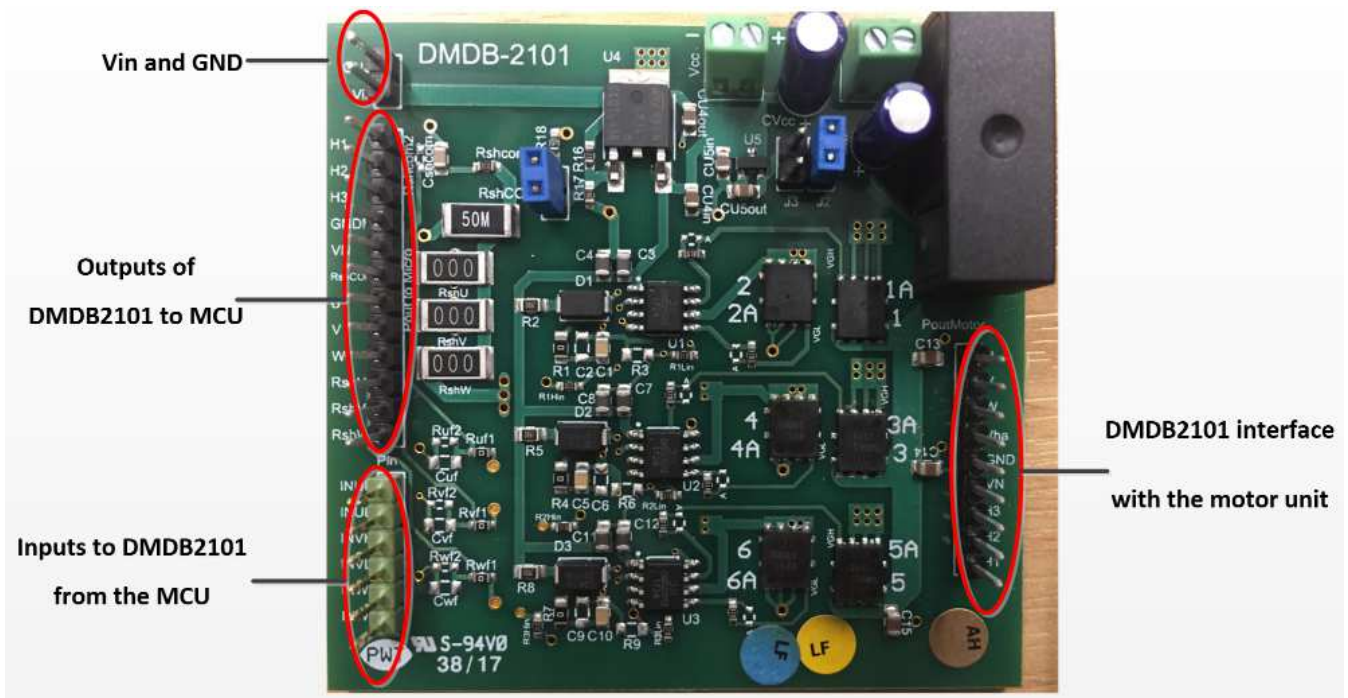

Figure 2. Interface headers on the board

Outputs of DMDB2101 to MCU (Pout to Micro):

The green 6-pin header present at the bottom left hand corner of the board (figure 2) is used to provide high side, low side inputs to the gate drivers on the board (INUH, INUL, INVH, INVH, INWH, INWL).

Inputs to DMDB2101 from the MCU (Pin):

The 12-pin header present on the left side of the board (figure2), provides all the inputs to the MCU board. This header provides all the signal inputs required by the MCU for the motor control (H1, H2, H3, GNDM, VN, RshCOM, U, V, W, RshU, RshV, RshW).

DMDB2101 interface with the motor unit (PoutMotor):

The 9-pin header present on the right-hand side of the board is used for the connections with the motor (U, V, W, Vha, GND, VN, H3, H2, H1).

This application note contains new product information. Diodes, Inc. reserves the right to modify the product specification without notice. No liability is assumed as a result of the use of this product. No rights under any patent accompany the sale of the product.

Power Inputs and protection:

The board have two voltage inputs, Vcc & Vm. Vcc provides the voltage to the drive circuit and Vm provides voltage to the Half bridges. Current consumption of the drive circuit from Vcc is low compared to the motor current 'Im' from Vm. A socket mounted 5A glass fuse is provided to protect the board from over currents that may flow into the motor.

Voltage regulator circuits:

There are two onboard voltage regulators AZ317DTR and ZXTR2105. AZ317 can be used to provide and adjustable (3.3V and 5V) voltage rails to the MCU board using jumper J1. Connect J1 with a bus bar to get 3.3V and leave it open for 5V. If the hall sensors are being used, they should be provided with a 5V supply. If AZ317DTR is set up to do 5V, the same 5V can be used to power the hall sensors by connecting the jumper J2. If the AZ317DTR is set up to provide 3.3V, use the jumper J3 to provide the required 5V using ZXTR2105.

Half bridges:

DMDB2101 comes with 3 half bridges. Each bridge is driven by a DGD2101M high side – low side gate driver (refer to figure 3). The high side MOSFET of the half bridge is driven by the voltage provided by a bootstrap capacitor, there for the high side MOSFET can never be driven with a 100% duty ratio. It should be turned off for a finite time to restore the charge of the bootstrap capacitor. Switching times of the high side and low side FETS can be individually controlled using the RGH and RGL resistors.

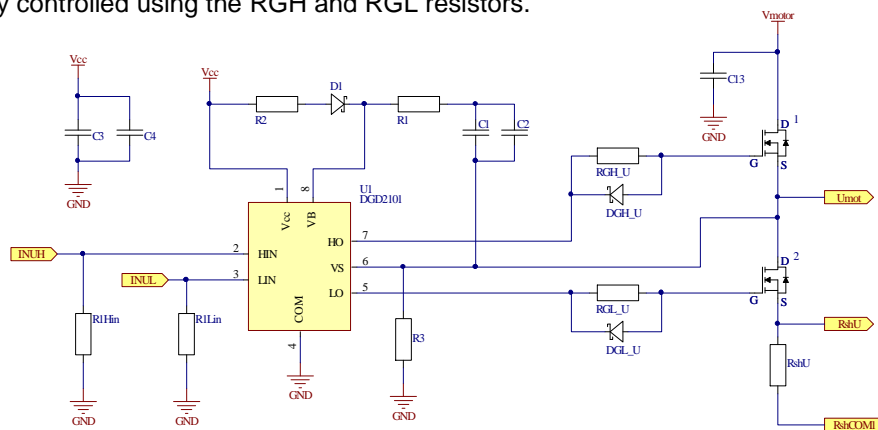

Figure 3: Half bridge drive circuit

Current in each phase can be monitored using the current sense resistor RshU/V/W and the total current can be monitored using the RshCOM. The boards come with a 50mOhm RshCOM1 for monitoring the overall current. If currents in the individual phases needs monitoring replace the onboard 0ohm resistors with appropriate resistor values. The board comes with a low pass filter (10K and 10nF) with a cutoff frequency of 1592Hz. This is adequate for most of the applications, but where necessary it can be tuned by choosing the appropriate RshCOM, CshCOM and RshCOM2 (refer to figure 4).

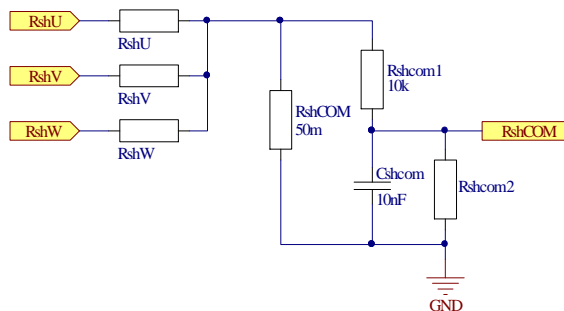

Figure 4: Current sense and current sense filtering circuit

This application note contains new product information. Diodes, Inc. reserves the right to modify the product specification without notice. No liability is assumed as a result of the use of this product. No rights under any patent accompany the sale of the product.

Back EMF and Hall sensor inputs:

The hall sensor outputs (H1, H2 and H3) collected at the motor interface header are fed directly into the MCU using the pins on the 12-pin header on the left-hand side of the board. The board supports the sensor less topologies that uses back EMF based control algorithms. Back EMF developed in each phase is measured by monitoring the voltage at U, V, W w.r.t the common node VN of the motor windings. The measured voltages at U, V, W (RshU, RshV, RshW) are fed to the MCU through an onboard filter, the board is not populated with these filter components to allow for custom tuning by the user if necessary. The voltage differences between RshU-VN, RshV-VN, RshW-VN gives the back EMF in the phases U, V and W respectively.

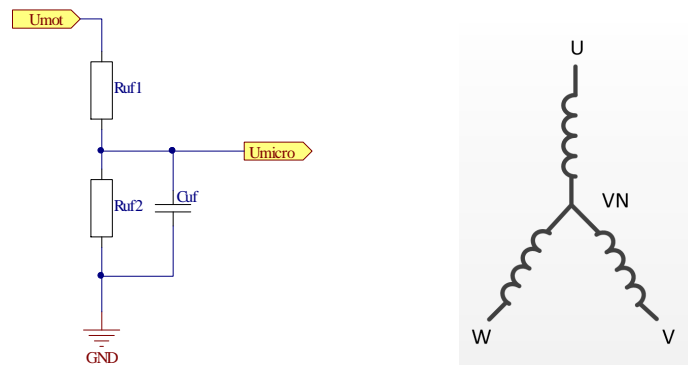

Figure 5: Back EMF filter and the 3 Phase terminology used.

Capacitors:

The board comes with the decoupling capacitors CVcc, CM, C13, C14, C15, C3, C7, C11, C4, C8, C12. Bootstrap capacitors C1, C5, C10 are mounted on the board and there are provisions for additional boot strap capacitance, C2, C6 & C9. The board also comes with Input – output capacitors for onboard regulators CU4in, CU4out, CU5in, CU5out and filtering capacitor CshCOM. There are also provisions for additional filtering Cuf, Cvf, Cwf.

Voltage and current ratings:

Vcc voltage rating is 20V maximum and 10V minimum. This limited by the operating window of the DGD2101M gate driver on board. Vm rating is limited by the MOSFET BVdss of 60V. The board in its current state is recommended for generic 12V and 24V motors.

Current is limited by the:

MOSFET's (DMT6004LPS) current rating = 90A (while not exceeding the datasheet thermal ratings)

Current sense resistors RshU, RshV, RshW, RshCOM = 1W power limitation ($P = I^2 \times R$)

Fuse F1 = 5A

Current rating of the motor interface header is 3A per contact.

Power rating that can achieved using the board with a Vm=12V is (12*5=)60W and Vm = 24V is (24*5=) 120W. However, these rating can be increased up to 330W, by increasing the fuse current rating and current rating of the header contact in combination with the 'Vm' voltage.

Extending the voltage rating of the motor:

The board's voltage rating can be extended up to 600V for evaluation purposes, for design purposes ensure clearance and creepage requirements are taken into account. However, Vm rating is primarily limited by the MOSFET's BVdss. Choosing a high voltage MOSFET enables high voltage motor driving. Other components that needs voltage rating extension are CM, C13, C14, C15, D1, D2 & D3. The voltage ratings of these components should match or better the voltage rating of the MOSFETs.

This application note contains new product information. Diodes, Inc. reserves the right to modify the product specification without notice. No liability is assumed as a result of the use of this product. No rights under any patent accompany the sale of the product.

BOM:

PCB IDENTIFICATION	Manufacturer part no	DESCRIPTION	Manufacturer
1, 2, 3, 4, 5, 6	DMT6004LPS	60V N-channel MOSFET	Diodes Inc
1A, 2A, 3A, 4A, 5A, 6A	DMT6007LFG	No fitted but compatible with MOSFETS in Pdi3333	Diodes Inc
C1, C5, C9	GCM21BR72A104KA37L	0.1µF ±10% 100V Ceramic Capacitor X7R 0805 (2012 Metric)	Generic
C3, C7, C11, C4, C8, C12	C2012X5R1V226M125AC	SMD Multilayer Ceramic Capacitor, 0805 [2012 Metric], 22 µF, 35 V, ± 20%, X5R, C Series	Generic
C13, C14, C15	GRM21BC72A105KE01L	1µF ±10% 100V Ceramic Capacitor X7S 0805 (2012 Metric)	Generic
, CU4in, CU4out, CU5in, CU5out,	CL21B105KBFNNNE	1µF ±10% 50V Ceramic Capacitor X7R 0805 (2012 Metric)	Generic
Cuf, Cvf, Cwf, C2, C6, C10,	Not Fitted	0805(2012metric) package. C2,C6,C10 rated to >35V and Cuf,Cvf,Cwf rating should be >Vm voltage	Generic
Cshcom	C0805C103K1RACTU	10000pF ±10% 100V Ceramic Capacitor X7R 0805 (2012 Metric)	Generic
CM	ECA2AM100	Panasonic Aluminium Electrolytic Capacitor 10µF 100 V dc 5mm Through Hole M Series Lifetime 2000h 85°C	Generic
CVcc	ECA1HM330	Panasonic Aluminium Electrolytic Capacitor 33µF 50 V dc 5mm Through Hole M Series Lifetime 2000h +85°C	Generic
D1, D2, D3	B2100A-13-F	Diode Schottky 2A Surface Mount SMA	Diodes Inc
DGH_V, DGH_W, DGL_U, DGL_V,	Not fitted	>20V & >1A rated Schottky diodes.	Generic
F1	65800001009	Fuse Holder 5mm*20mm. FUSE BLOK CARTRIDGE 250V 10A SMD	Generic
Vin, J1, J2, J3,	2211S-02G	Header 2-pin. Vertical, 2.54 mm, 2 Contacts, Header, 2211S Series, Through Hole, 1 Rows	Generic
Vm, Vcc	1725656	Phoenix Terminal Block, 2 way, 1725656	Generic
Pin	<u>826629-6</u>	Wire-To-Board Connector, 2.54 mm, 6 Contacts, Header, AMPMODU MOD II Series, Through Hole, 1 Rows	Generic
Pout to Micro	0901200132	12 Positions Header, Breakaway Connector 0.100" (2.54mm) Through Hole Tin	Generic
PoutMotor	0901200129	9 Positions Header, Breakaway Connector 0.100" (2.54mm) Through Hole Tin	Generic
R1, R4, R7	RC0805JR-070RL	RES SMD 0 OHM JUMPER 1/8W 0805	Generic
R2, R5, R8	ESR10EZPF2R00	RES SMD 2 OHM 1% 0.4W 0805	Generic
R3, R6, R9	Not fitted	resistors in 0805 package, usually a >20K resistor to pre charge the bootstrap capacitor. Not always necessary.	Generic
R16	CPF-A-0603B120RE	RES SMD 120 OHM 0.1% 1/16W 0603	Generic
R18	RMCF0603FT430R	RES SMD 430 OHM 1% 1/10W 0603	Generic
R17	A124002CT-ND	RES SMD 360 OHM 0.1% 1/16W 0603	Generic
RGH_V, RGH_W, RGL_U, RGL_V,	RP73PF1J10RBTFD	RES SMD 10 OHM 0.1% 1/6W 0603	Generic
Rshcom2, Rvf2, Rvf2, Rwf2	Not fitted	Filter resistors in 0603 package	Generic
Ruf1, Rvf1, Rwf1	RMCF0603ZT0R00	RES SMD 0 OHM JUMPER 1/10W 0603	Generic
,R1hin, R1lin, R2Hin, R2Lin, R3Hin, R3Lin, Rshcom1	RP73PF1J10KBTFD	RES SMD 10K OHM 0.1% 1/6W 0603	Generic
RshU, RshV, RshW	RC6432J000CS	RES SMD 0 OHM JUMPER 1W 2512	Generic
RshCOM,	ERJ-L1WKF50MU	RES SMD 50 MOHM 1% 1W 2512	Generic
U1, U2, U3	DGD2101M	High side low side gate driver	Generic
U4	AZ317D	IC REG LINEAR POS ADJ 500MA DPAK	Diodes Inc
U5	ZXTR2105F	IC REG LINEAR 5V 89MA SOT23	Diodes Inc
	M7571-05	M7571-05 - Jumper (Busbar), Jumper Socket, Harwin M20 Pin Header Connectors, 2 Ways, 2.54 mm	Generic
	66000001009	Fuse holder cover. COVER FUSE BLACK FOR 656/658	Generic
	0217005.HXP	Fuse glass 5A 250VAC 5*20mm	Generic

This application note contains new product information. Diodes, Inc. reserves the right to modify the product specification without notice. No liability is assumed as a result of the use of this product. No rights under any patent accompany the sale of the product.

Circuit Schematic:

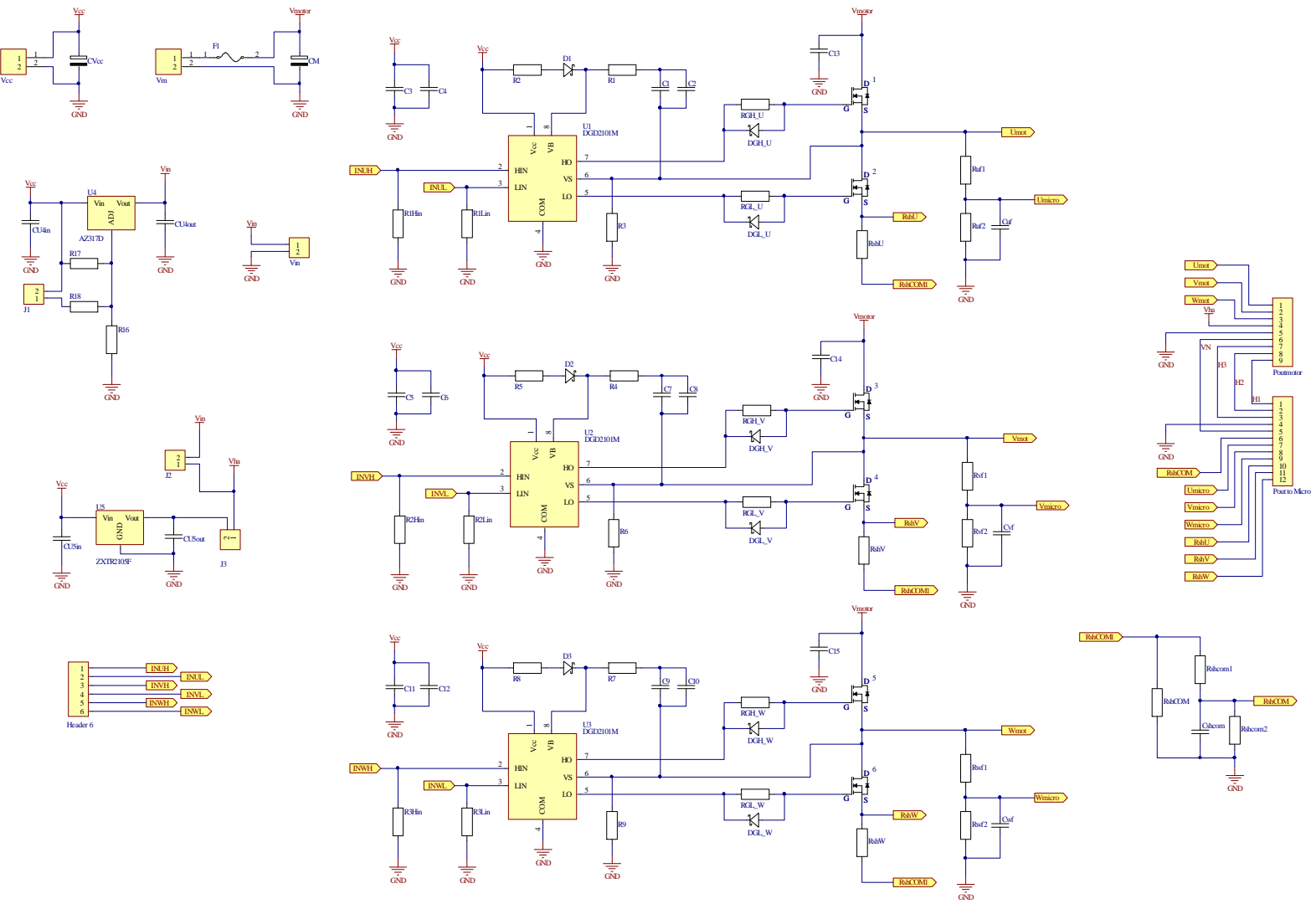

This application note contains new product information. Diodes, Inc. reserves the right to modify the product specification without notice. No liability is assumed as a result of the use of this product. No rights under any patent accompany the sale of the product.

PCB schematic:

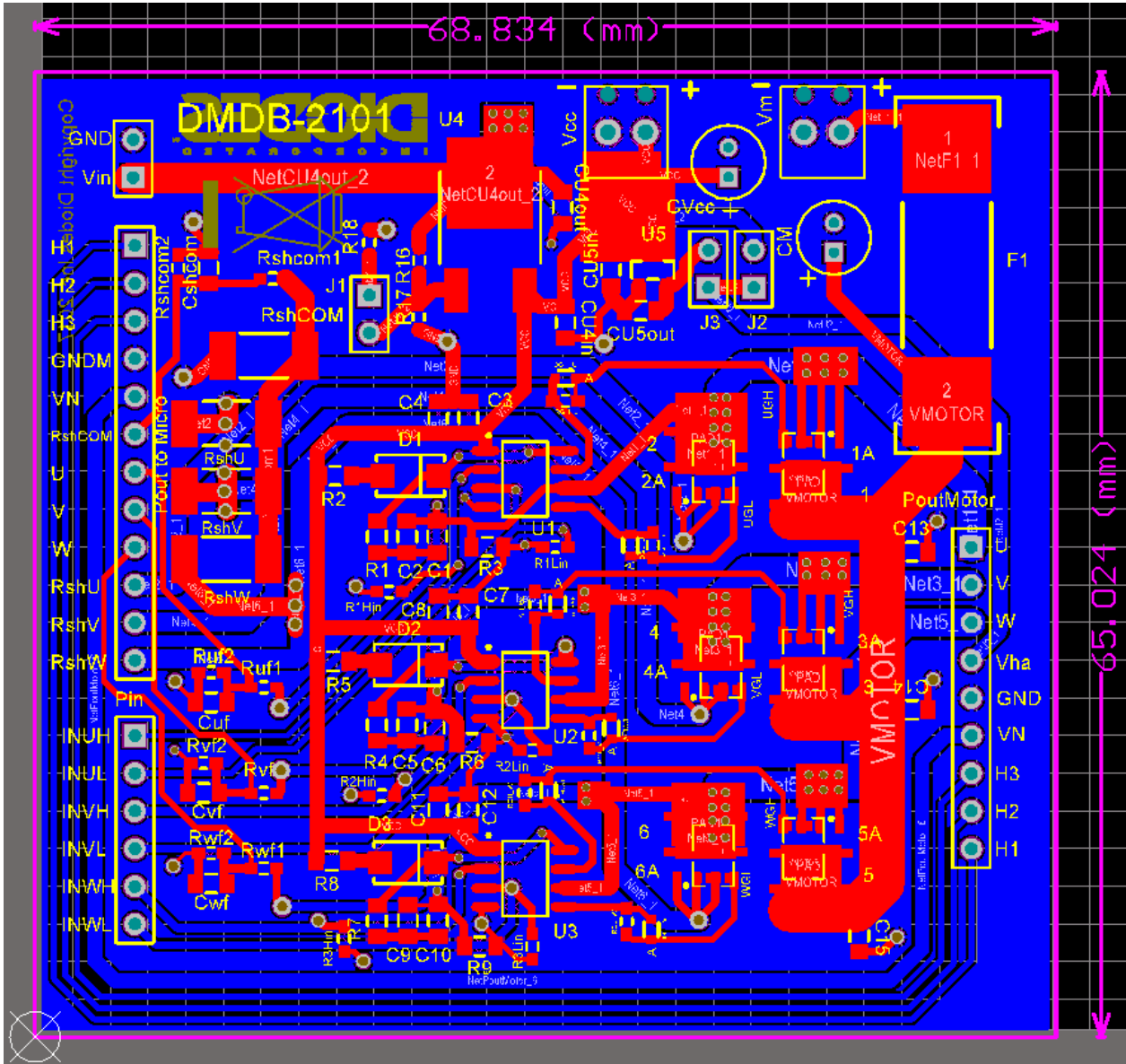

This application note contains new product information. Diodes, Inc. reserves the right to modify the product specification without notice. No liability is assumed as a result of the use of this product. No rights under any patent accompany the sale of the product.

Input signal sequence from the MCU:

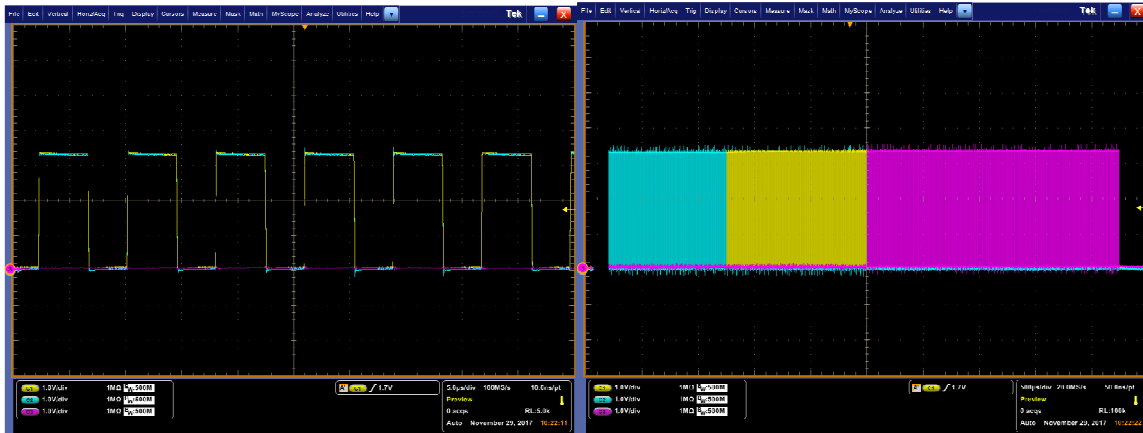

MCU Input signals Per Phase (high-side and low side) MCU PhaseU-High side & PhaseV,W Low Side

Input – Output signal timing:

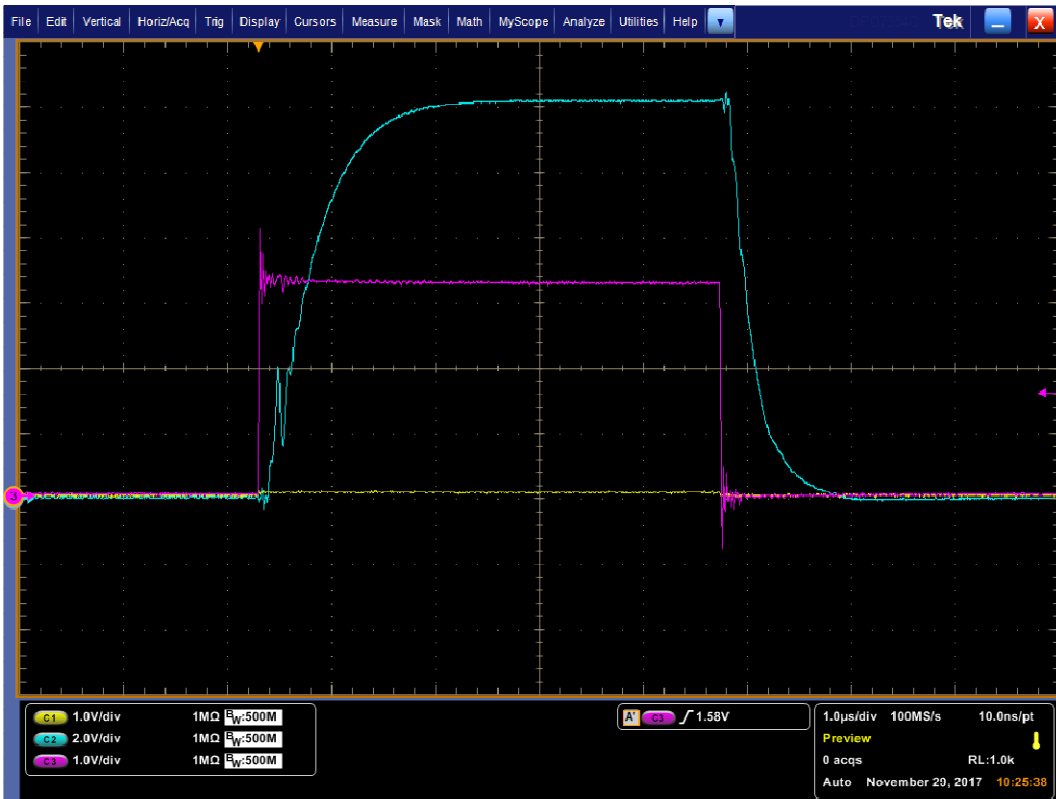

MCU Input to Phase V low side & Phase V low side output of the gate driver

This application note contains new product information. Diodes, Inc. reserves the right to modify the product specification without notice. No liability is assumed as a result of the use of this product. No rights under any patent accompany the sale of the product.

IMPORTANT NOTICE

DIODES INCORPORATED MAKES NO WARRANTY OF ANY KIND, EXPRESS OR IMPLIED, WITH REGARDING TO THIS DOCUMENT, INCLUDING, BUT NOT LIMITED TO, THE IMPLIED WARRANTIES OF MERCHANTABILITY AND FITNESS FOR A PARTICULAR PURPOSE (AND THEIR EQUIVALENTS UNDER THE LAWS OF ANY JURISDICTION).

Diodes Incorporated and its subsidiaries reserve the right to make modifications, enhancements, improvements, corrections or other changes without further notice to this document and any product described herein. Diodes Incorporated does not assume any liability arising out of the application or use of this document or any product described herein; neither does Diodes Incorporated convey any license under its patent or trademark rights, nor the rights of others. Any Customer or user of this document or products described herein in such applications shall assume all risks of such use and will agree to hold Diodes Incorporated and all the companies whose products are represented on Diodes Incorporated website, harmless against all damages.

Diodes Incorporated does not warrant or accept any liability whatsoever in respect of any products purchased through unauthorized sales channel.

Should Customers purchase or use Diodes Incorporated products for any unintended or unauthorized application, Customers shall indemnify and hold Diodes Incorporated and its representatives harmless against all claims, damages, expenses, and attorney fees arising out of, directly or indirectly, any claim of personal injury or death associated with such unintended or unauthorized application.

Products described herein may be covered by one or more United States, international or foreign patents pending. Product names and markings noted herein may also be covered by one or more United States, international or foreign trademarks.

LIFE SUPPORT

Diodes Incorporated products are specifically not authorized for use as critical components in life support devices or systems without the express written approval of the Chief Executive Officer of Diodes Incorporated. As used herein:

A. Life support devices or systems are devices or systems which:

1. are intended to implant into the body, or
2. support or sustain life and whose failure to perform when properly used in accordance with instructions for use provided in the labeling can be reasonably expected to result in significant injury to the user.

B. A critical component is any component in a life support device or system whose failure to perform can be reasonably expected to cause the failure of the life support device or to affect its safety or effectiveness.

Customers represent that they have all necessary expertise in the safety and regulatory ramifications of their life support devices or systems, and acknowledge and agree that they are solely responsible for all legal, regulatory and safety-related requirements concerning their products and any use of Diodes Incorporated products in such safety-critical, life support devices or systems, notwithstanding any devices- or systems-related information or support that may be provided by Diodes Incorporated. Further, Customers must fully indemnify Diodes Incorporated and its representatives against any damages arising out of the use of Diodes Incorporated products in such safety-critical, life support devices or systems.

Copyright © 2018, Diodes Incorporated

www.diodes.com