AN1147

Application Note for DPS1133

Elaine Jiang, Diodes Incorporated

Introduction

The DPS1133 is a unidirectional power switch for USB power delivery with protections for overvoltage, overcurrent, output short circuit, reversed voltage, reversed current, and overtemperature conditions. It can support up to 84W of output power with user programmable capability. This document is written for engineers using DPS1133 in the USB power delivery circuit to obtain setup information. To simplify the task, this paper will go directly to the basic configuration for DPS1133 to operate and then to a specific example to demonstrate how to select components to achieve design targets.

Designing with DPS1133

1. Capacitance required for IN and OUT ports, C_{IN} and C_{OUT} . The DPS1133 is rated for 24V on the input port and 3.5A continuous load on the output port. In order to support the rated power, 10uF capacitance on the input and output ports is recommended.
2. Define the operating voltage range, V_{LIM} .
The DPS1133 has an operating voltage from 4.5V to 24V. The operating voltage is set by the resistance between the V_{LIM} and GND pins, R_{VLIM} . The larger the R_{VLIM} , the higher the operating voltage it can support. R_{VLIM} can be chosen according to:

$$R_{VLIM} = [1.1 \times V_{in}] / 0.1mA$$

and

$$51K\Omega \leq R_{VLIM} \leq 270K\Omega$$

When the DPS1133 carries a load, large voltage spikes will be imposed on top of the set input voltage when the load is being removed. If no or not enough voltage margin is applied, the voltage on the input port will go beyond the overvoltage threshold V_{OVPTH} , cause device shutdown and then turn back on due to the load drop out, resulting in an unstable system. To eliminate this problem, a 5 ~ 20% voltage margin is recommended. In this R_{VLIM} calculation, a 10% of margin, $[1.1 \times V_{in}]$ is being applied.

Once R_{VLIM} is chosen, the overvoltage threshold V_{OVPTH} is automatically set by design, which is

$$V_{OVPTH} = [1.1 \times V_{in}] + 0.5V$$

For an example, for a 12V input application, with 10% input voltage margin,

$$R_{VLIM} = [1.1 \times 12V] / 0.1mA = 132 K\Omega$$

With $R_{VLIM} = 132 K\Omega$, the voltage spike on the input port can swing up to $V_{in} = 1.1 \times 12V = 13.2V$ without triggering the overvoltage threshold V_{OVPTH} , and from the equation above,

$$V_{OVPTH} = [1.1 \times 12] + 0.5V = 13.7V$$

3. Device enable, EN
For the DPS1133 to work, the EN pin must pull to a logic high voltage. Tie the EN pin to a 2V DC supply enables the device output. If the voltage at the input port is within operating range, the output will ramp up to the desired voltage.

4. Current limit and over current setting, ILIM

The resistor between the ILIM and GND pins, R_{ILIM}, sets the device's current limit and will clamp the output current to this limit even when the load is demanding for more power.

The output current limit can be set according to the following:

$$R_{ILIM} = 100 / I_{ILIM},$$

Where:

- I_{ILIM} is in ampere
- R_{ILIM} is in KΩ
- 27KΩ ≤ R_{ILIM} ≤ 200KΩ

For an example, for a 2A current limit application,

$$R_{ILIM} = 100 / 2 = 50 \text{ K}\Omega$$

When the output current is founded to be larger than the programmed ILIM level (2A in this case) for more than 2us, the device goes to protection mode by clamping the output current to the programmed 2A and the output voltage will drop down significantly, to a level around or less than 25% of the input voltage.

For applications require continuous current from the output, a 10 ~ 20% margin should apply. To apply this margin, follow

$$R_{ILIM} = 100 / [I_{ILIM} \times 1.2]$$

From the above example, if a maximum 2A of continues current is required, we apply a 20% margin, and R_{ILIM} can be calculated by following

$$R_{ILIM} = 100 / [I_{ILIM} \times 1.2] = 100 / [2 \times 1.2] = 41.7 \text{ K}\Omega$$

5. Short circuit protection setting, ILIM

In the event of output short circuit, the output current will rise rapidly. When this current exceeds the fast-trip threshold I_{FASTTRIP}, the device will be turned off immediately to protect the device from being damaged.

The I_{FASTTRIP} is also set by the ILIM current, I_{ILIM},

$$I_{FASTTRIP} = 1.125 \times I_{ILIM} + 1.8$$

Where I_{ILIM} is in ampere.

For ILIM at 2A, I_{FASTTRIP} is calculated to: I_{FASTTRIP} = 1.125 x 2 + 1.8 = 4.05A

Another method of protection is through voltage trip. When the device is under heavy load condition, the output voltage will rapidly drop below 25% of the input voltage, with its output current limit to I_{ILIM} at the meantime. When the heavy load condition is removed, the device will resume normal operation.

6. Output current monitoring, IMON

Output current monitoring is through the resistor between the IMON and GND pins, R_{IMON}. To prevent noise from entering into the IMON pin, a 100pF capacitor is placed across the IMON and GND pins. R_{IMON} should be chosen such that the voltage across the IMON pin, V_{IMON} is below 4.5V. By design, a 10uA current on IMON pin will be generated for every 1A load at the output, therefore, output current sensing can be obtained from the voltage drop at the IMON pin, V_{IMON}:

$$V_{IMON} = (10\mu\text{A}/\text{A}) \times I_{OUT} \times R_{IMON}, \text{ where } R_{IMON} \text{ is in K}\Omega$$

$$\text{and } V_{IMON} < 4.5\text{V}$$

For an example, if a 2A load is presented on the output, with $R_{IMON} = 100\text{ K}\Omega$, V_{IMON} will be 2V. The calculation is as following:

$$V_{IMON} = (10\mu\text{A/A}) \times (2\text{A}) \times (100\text{ K}\Omega) = 2\text{V}$$

7. Output ramp time control, DV/DT

The capacitor placed between the DV/DT and GND pins sets the output voltage ramp rate at the device turn on. This ramp time is determined by the capacitance from the DV/DT pin to ground, $C_{DV/DT}$:

$$C_{DV/DT} = t_{DV/DT} / [8.3 \times 10^{-2} \times V_{IN}]$$

Where $t_{DV/DT}$ is the total ramp time in ms

and the unit of V_{IN} is volt, $C_{DV/DT}$ is nF.

For an example, if the output ramp time from 0V to 12V is specified to be 1ms, the required capacitance $C_{DV/DT}$ is calculated to be:

$$C_{DV/DT} = t_{DV/DT} / [8.3 \times 10^{-2} \times V_{IN}] = 1000\text{ms} / [8.3 \times 10^{-2} \times 12\text{V}] = 1\text{nF}$$

Please refer to the DPS1133 datasheet for more information on output ramp control

8. Fast role swap control, FRS

To enable fast role swap, a positive pulse with 2V of amplitude is applied to the FRS pin. FRS is taken action after the FRS transition low for a certain time. Please refer to Figure 1 and 2 for details on the FRS timing requirements. When FRS function is not used, simply leave the FRS pin open or tie it to ground.

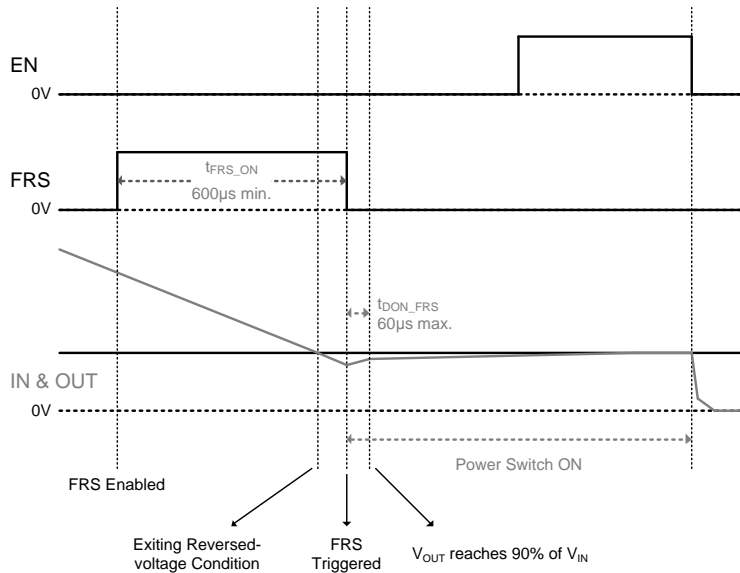
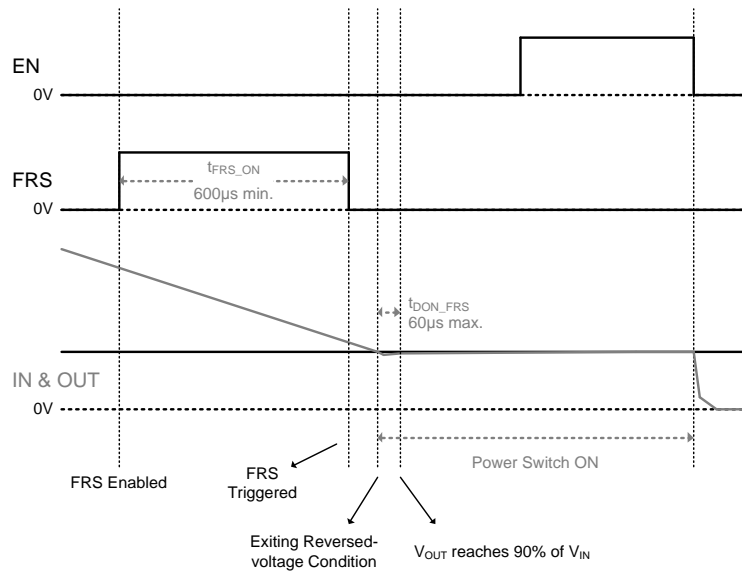

Figure 1. FRS Control Sequence for Fast Role Swap Power Switch ON at Falling Edge of FRS Signal after Exiting RVP Condition



**Figure 2. FRS Control Sequence for Fast Role Swap
Power Switch ON When Exiting RVP Condition after FRS is Triggered (Falling Edge)**

9. Discharge function, DISC1 and DISC2
To discharge the input and output port, a positive voltage must be applied to the DISC1 and DISC2 pins respectively. A 2V voltage is sufficient to discharge the ports.
10. Regulated voltage, VREG
The internal regulator voltage can be monitored via the VREG pin. For smooth regulator voltage, a 0.1µF capacitor should be placed from the VREG pin to GND. The nominal VREG voltage is 5V.
11. Fault status reporting, FAULTB
In the events of the input overvoltage, overcurrent, reversed voltage, reversed current, short-circuit, ILIM short to ground and over temperature conditions, the device will generate a fault signal by pulling the FAULTB voltage, V_{FAULTB} low. V_{FAULTB} will remain low until all of the above conditions have cleared. A pull up resistor, R_{PU} from FAULTB to a supply voltage of 5V will satisfy the fault reporting needs. To filter out the noise, a 0.1µF capacitor is placed from the FAULTB pin to ground. The R_{PU} resistor should not be too large, especially when quick FAULTB response time is required. Generally a 10 kΩ R_{PU} or smaller is recommended.

A typical application circuit below demonstrates the general settings for the DPS1133 device circuit.

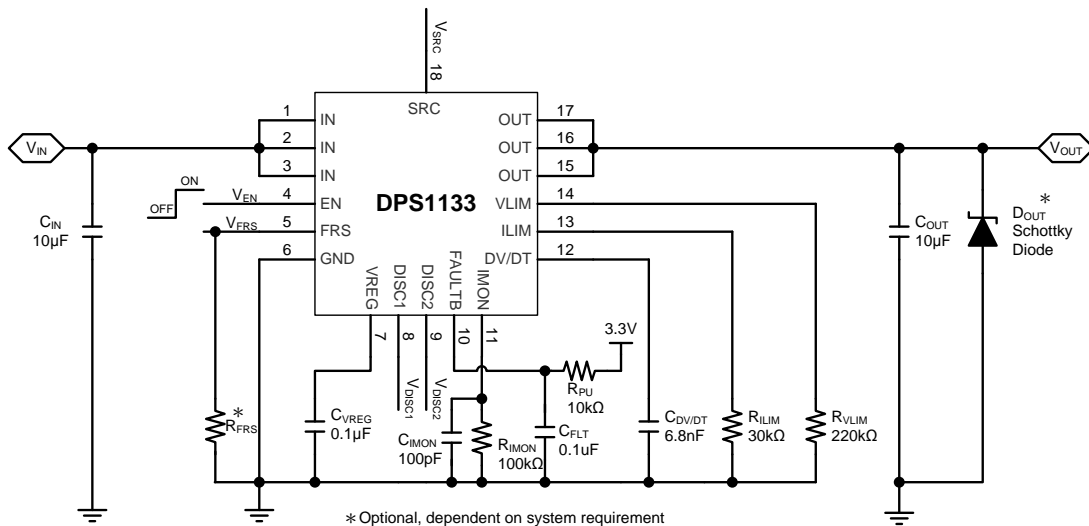

Figure 3. Typical application circuit for DPS1133

IMPORTANT NOTICE

DIODES INCORPORATED MAKES NO WARRANTY OF ANY KIND, EXPRESS OR IMPLIED, WITH REGARDS TO THIS DOCUMENT, INCLUDING, BUT NOT LIMITED TO, THE IMPLIED WARRANTIES OF MERCHANTABILITY AND FITNESS FOR A PARTICULAR PURPOSE (AND THEIR EQUIVALENTS UNDER THE LAWS OF ANY JURISDICTION).

Diodes Incorporated and its subsidiaries reserve the right to make modifications, enhancements, improvements, corrections or other changes without further notice to this document and any product described herein. Diodes Incorporated does not assume any liability arising out of the application or use of this document or any product described herein; neither does Diodes Incorporated convey any license under its patent or trademark rights, nor the rights of others. Any Customer or user of this document or products described herein in such applications shall assume all risks of such use and will agree to hold Diodes Incorporated and all the companies whose products are represented on Diodes Incorporated website, harmless against all damages.

Diodes Incorporated does not warrant or accept any liability whatsoever in respect of any products purchased through unauthorized sales channel.

Should Customers purchase or use Diodes Incorporated products for any unintended or unauthorized application, Customers shall indemnify and hold Diodes Incorporated and its representatives harmless against all claims, damages, expenses, and attorney fees arising out of, directly or indirectly, any claim of personal injury or death associated with such unintended or unauthorized application.

Products described herein may be covered by one or more United States, international or foreign patents pending. Product names and markings noted herein may also be covered by one or more United States, international or foreign trademarks.

This document is written in English but may be translated into multiple languages for reference. Only the English version of this document is the final and determinative format released by Diodes Incorporated.

LIFE SUPPORT

Diodes Incorporated products are specifically not authorized for use as critical components in life support devices or systems without the express written approval of the Chief Executive Officer of Diodes Incorporated. As used herein:

A. Life support devices or systems are devices or systems which:

1. are intended to implant into the body, or
2. support or sustain life and whose failure to perform when properly used in accordance with instructions for use provided in the labeling can be reasonably expected to result in significant injury to the user.

B. A critical component is any component in a life support device or system whose failure to perform can be reasonably expected to cause the failure of the life support device or to affect its safety or effectiveness.

Customers represent that they have all necessary expertise in the safety and regulatory ramifications of their life support devices or systems, and acknowledge and agree that they are solely responsible for all legal, regulatory and safety-related requirements concerning their products and any use of Diodes Incorporated products in such safety-critical, life support devices or systems, notwithstanding any devices- or systems-related information or support that may be provided by Diodes Incorporated. Further, Customers must fully indemnify Diodes Incorporated and its representatives against any damages arising out of the use of Diodes Incorporated products in such safety-critical, life support devices or systems.

Copyright © 2018, Diodes Incorporated

www.diodes.com