

# ZXLD383EV1 USER GUIDE

## DESCRIPTION

The ZXLD383 is a single or multi-cell LED driver designed for applications requiring step-up voltage conversion from a very low input voltage. The IC generates constant current pulses that are ideal for driving single or multiple LEDs over a wide range of operating voltages. It includes an on/off enable input that can be driven directly from a photocell array or an open collector/drain logic output. The enable input features an ultra-low-voltage-drop diode to ground, eliminating the need for a photocell array isolation diode in Garden Light applications.

The ZXLD383 uses a PFM control technique to drive an internal switching transistor which exhibits a low saturation resistance. This ensures high efficiency, even for input voltages as low as 1.0V.

The IC can start up under full load and operates down to an input voltage of below 0.9V.

The ZXLD383 is offered in the space-saving SOT23-5 package or in die form, offering an excellent cost-versus-performance solution for single-cell LED driving applications.

## FEATURES

- 85% Efficiency
- User adjustable output current
- Single cell operation (0.9V minimum)
- Low-saturation-voltage switching transistor
- SOT23-5 package
- Available also in Die form
- Simple Application circuit

## APPLICATIONS

- Garden lights
- Door/Pathway illumination
- LED flashlights and torches
- LED backlights
- White LED drivers
- Gated Boost Supply Generators

## ORDERING INFORMATION

<b>ORDER NUMBER</b>
---------------------

ZXLD383EV1
------------

Please note that evaluation boards are subject to availability and qualified leads.

## TYPICAL APPLICATION CIRCUIT

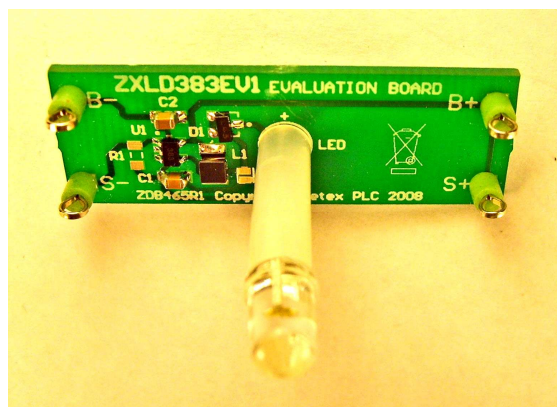
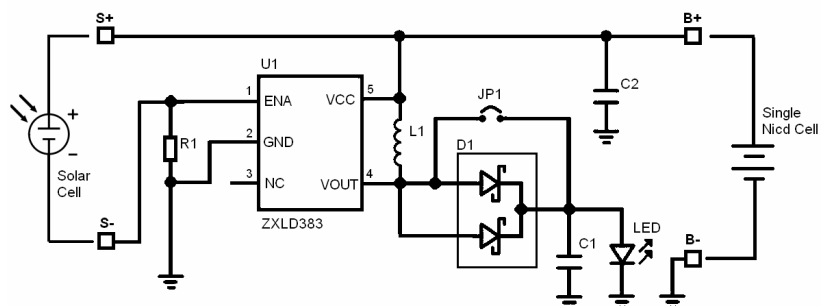

REFERENCE DESIGN

The ZXLD383EV1 evaluation board is designed to drive a 5mm type white LED. The target application is single-cell LED driving for garden lights.

The board is designed to accept a single rechargeable NiCd cell as the voltage source, with a voltage range from 1.4V down to 0.9V. The positive and negative of the NiCd cell should be connected to the B+ and B- terminals respectively.

For battery charging purposes, the positive and negative output terminals of the solar cell should be connected to the S+ and S- terminals respectively.

During daytime, current produced from the solar cell will charge up the NiCd cell through the internal ultra-low-dropout diode between the ENA pin and the GND pin. Negative voltage appearing at ENA pin will inhibit the LED driver.

During night-time, the current produced by the solar cell will drop to a low level, which will cause the negative voltage of the ENA pin to drop. This will enable the LED driver. The change-over threshold may also be adjusted by the optional bypass resistor R1.

In order to maximize the LED light output efficiency and reliability, the evaluation board is set to operate in low-ripple-LED-current mode with the use of the D1 and C1. The LED current is set at 18mA with using an inductor value of 15uH.

Alternatively, the evaluation board could be configured to operate in standard-mode in order to obtain higher electrical efficiency. This could be done by shorting jumper JP1 and removing output capacitor C1.

For other reference designs or further applications information, please refer to the ZXLD383 datasheet.

SCHEMATIC DIAGRAM

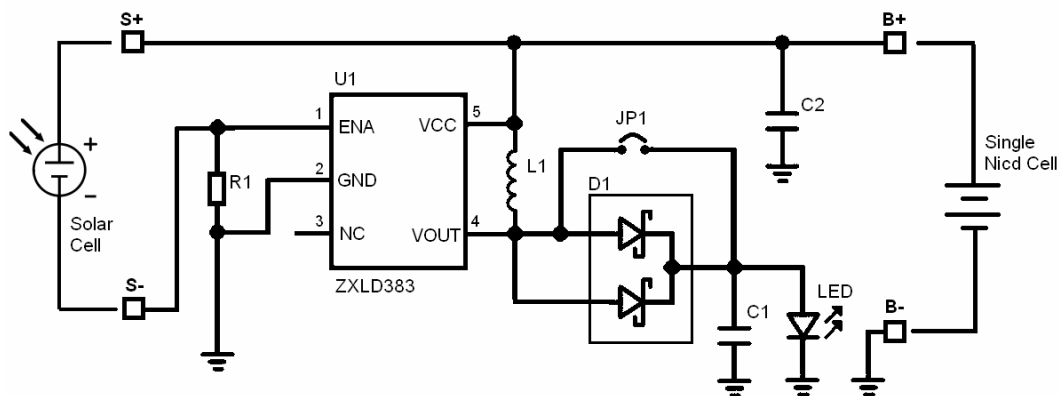

Materials List

Ref	Value	Package	Part Number	Manufacturer	Contact Details
U1	LED Driver	SOT23-5	ZXLD383ET5TA	Zetex	<a href="http://www.diodes.com">www.diodes.com</a>
D1	Dual Schottky Diode	SOT23	BAT54C	Diodes Zetex	<a href="http://www.diodes.com">www.diodes.com</a> <a href="http://www.diodes.com">www.diodes.com</a>
L1	15uH	1206	LQH32CN150K53	Murata	<a href="http://www.murata.com">www.murata.com</a>
C1 C2	470nF 25V X7R	0805	GRM219R71E474KKA 88B	Murata	<a href="http://www.murata.com">www.murata.com</a>
R1	Not fitted	0805		Generic	
LED	5mm White LED		HLMP-CW30-PS000	Avago	<a href="http://www.avagotech.com">www.avagotech.com</a>
LED Spacer	20mm LED Spacer		Generic		

PERFORMANCE

Graphs

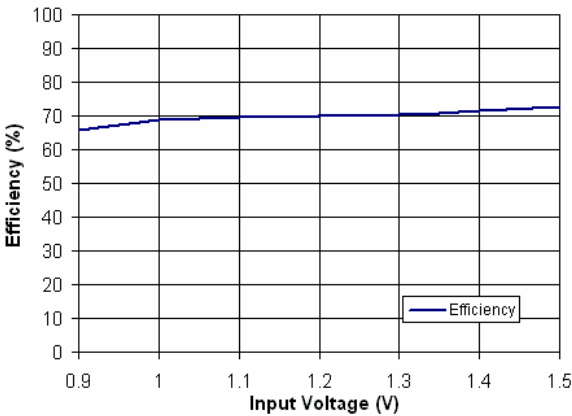

Efficiency vs Input Voltage

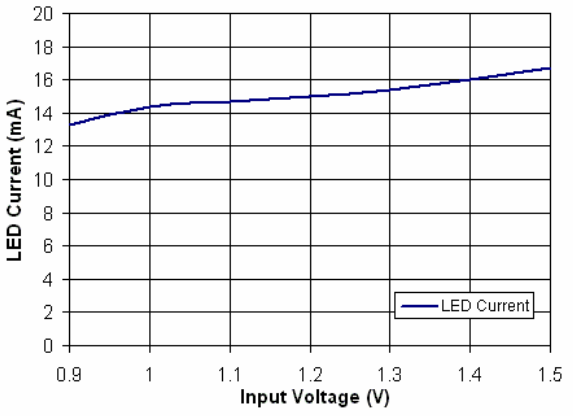

LED Current vs Input Voltage

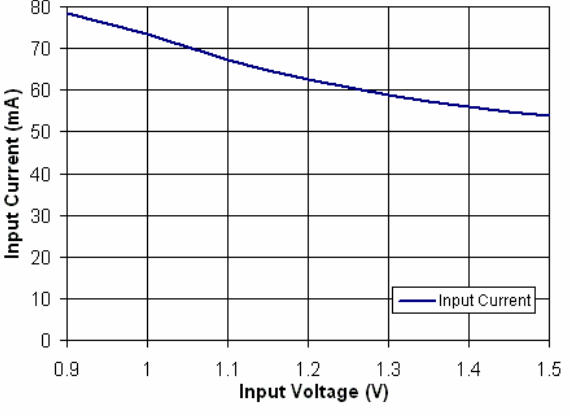

Input Current vs Input Voltage

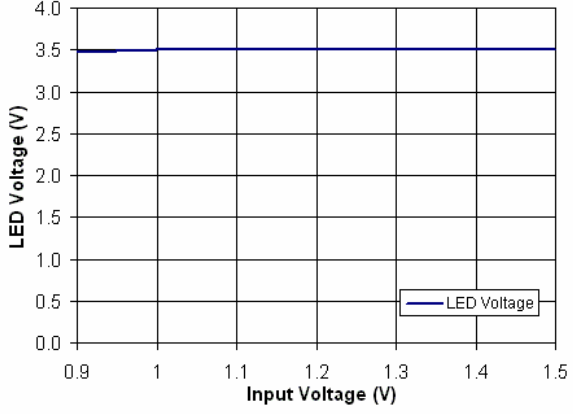

LED voltage vs Input Voltage

---

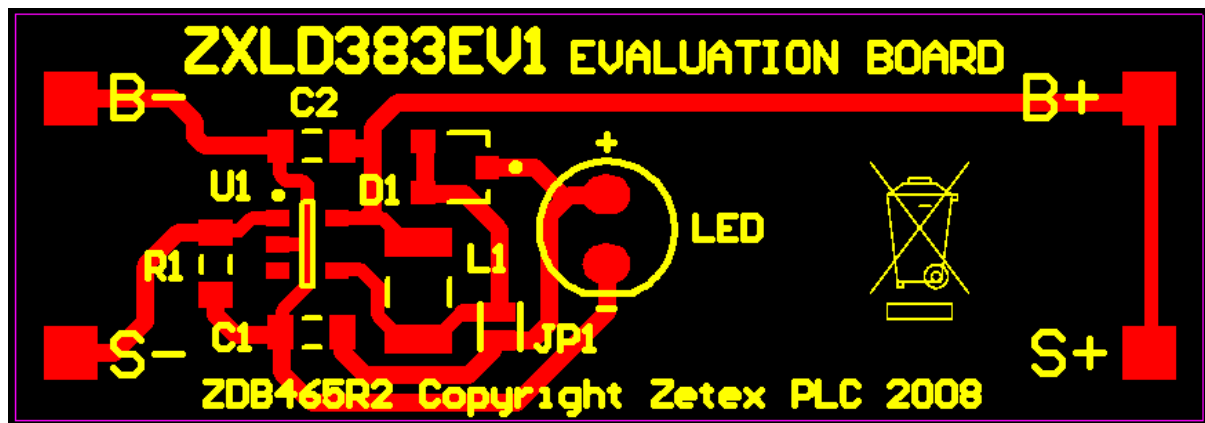
**ZXLD383EV1 OPERATION****Connection diagram****ZXLD383EV1 Set-up and Test**

1. Set a PSU to 1.5V with a current limit of around 100mA.
2. Connect a wire between the S+ and S- terminals.
3. Connect B+ and B- to positive and zero volts respectively, of the power supply.
4. Turn on the PSU.
5. The LED should illuminate.
6. The input current should measure between 45mA - 65mA.
7. Turn off the PSU
8. Disconnect the wire between S+ and S-.
9. Connect a wire between S- and B-
10. Turn on the PSU
11. The LED should stay off.  
End of test

**Layout considerations**

PCB tracks should be kept as short as possible to minimize ground bounce. It is particularly important to mount the coil and the input/output capacitors close to the device to minimize parasitic resistance and inductance, which will degrade efficiency. Recommended layout of the ZXLD383EV1 is shown below.



Top Silk

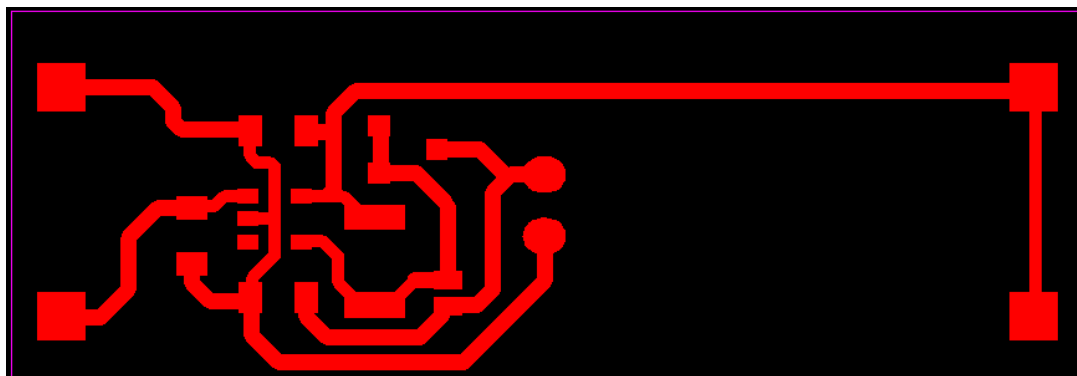

Top Copper

**Definitions**

**Product change**

Zetex Semiconductors reserves the right to alter, without notice, specifications, design, price or conditions of supply of any product or service. Customers are solely responsible for obtaining the latest relevant information before placing orders.

**Applications disclaimer**

The circuits in this design/application note are offered as design ideas. It is the responsibility of the user to ensure that the circuit is fit for the user's application and meets with the user's requirements. No representation or warranty is given and no liability whatsoever is assumed by Zetex with respect to the accuracy or use of such information, or infringement of patents or other intellectual property rights arising from such use or otherwise. Zetex does not assume any legal responsibility or will not be held legally liable (whether in contract, tort (including negligence), breach of statutory duty, restriction or otherwise) for any damages, loss of profit, business, contract, opportunity or consequential loss in the use of these circuit applications, under any circumstances.

**Life support**

Zetex products are specifically not authorized for use as critical components in life support devices or systems without the express written approval of the Chief Executive Officer of Zetex Semiconductors plc. As used herein:

- A. Life support devices or systems are devices or systems which:
  - 1. are intended to implant into the body
- or
- 2. support or sustain life and whose failure to perform when properly used in accordance with instructions for use provided in the labeling can be reasonably expected to result in significant injury to the user.
- B. A critical component is any component in a life support device or system whose failure to perform can be reasonably expected to cause the failure of the life support device or to affect its safety or effectiveness.

**Reproduction**

The product specifications contained in this publication are issued to provide outline information only which (unless agreed by the company in writing) may not be used, applied or reproduced for any purpose or form part of any order or contract or be regarded as a representation relating to the products or services concerned.

**Terms and Conditions**

All products are sold subjects to Zetex' terms and conditions of sale, and this disclaimer (save in the event of a conflict between the two when the terms of the contract shall prevail) according to region, supplied at the time of order acknowledgement.

For the latest information on technology, delivery terms and conditions and prices, please contact your nearest Zetex sales office.

**Quality of product**

Zetex is an ISO 9001 and TS16949 certified semiconductor manufacturer.

To ensure quality of service and products we strongly advise the purchase of parts directly from Zetex Semiconductors or one of our regionally authorized distributors. For a complete listing of authorized distributors please visit: [www.zetex.com/salesnetwork](http://www.zetex.com/salesnetwork)

Zetex Semiconductors does not warrant or accept any liability whatsoever in respect of any parts purchased through unauthorized sales channels.

**ESD (Electrostatic discharge)**

Semiconductor devices are susceptible to damage by ESD. Suitable precautions should be taken when handling and transporting devices. The possible damage to devices depends on the circumstances of the handling and transporting, and the nature of the device. The extent of damage can vary from immediate functional or parametric malfunction to degradation of function or performance in use over time. Devices suspected of being affected should be replaced.

**Green compliance**

Zetex Semiconductors is committed to environmental excellence in all aspects of its operations which includes meeting or exceeding regulatory requirements with respect to the use of hazardous substances. Numerous successful programs have been implemented to reduce the use of hazardous substances and/or emissions.

All Zetex components are compliant with the RoHS directive, and through this it is supporting its customers in their compliance with WEEE and ELV directives.

**Product status key:**

- "Preview" Future device intended for production at some point. Samples may be available
- "Active" Product status recommended for new designs
- "Last time buy (LTB)" Device will be discontinued and last time buy period and delivery is in effect
- "Not recommended for new designs" Device is still in production to support existing designs and production
- "Obsolete" Production has been discontinued

**Datasheet status key:**

- "Draft version" This term denotes a very early datasheet version and contains highly provisional information, which may change in any manner without notice.
- "Provisional version" This term denotes a pre-release datasheet. It provides a clear indication of anticipated performance. However, changes to the test conditions and specifications may occur, at any time and without notice.
- "Issue" This term denotes an issued datasheet containing finalized specifications. However, changes to specifications may occur, at any time and without notice.

Europe	Americas	Asia Pacific	Corporate Headquarters
Zetex GmbH Kustermann-park Balanstraße 59 D-81541 München Germany Telefon: (49) 89 45 49 49 0 Fax: (49) 89 45 49 49 49 europe.sales@zetex.com	Zetex Inc 700 Veterans Memorial Highway Hauppauge, NY 11788 USA Telephone: (1) 631 360 2222 Fax: (1) 631 360 8222 usa.sales@zetex.com	Zetex (Asia Ltd) 3701-04 Metroplaza Tower 1 Hing Fong Road, Kwai Fong Hong Kong Telephone: (852) 26100 611 Fax: (852) 24250 494 asia.sales@zetex.com	Zetex Semiconductors plc Zetex Technology Park, Chadderton Oldham, OL9 9LL United Kingdom Telephone (44) 161 622 4444 Fax: (44) 161 622 4446 hq@zetex.com

© 2006 Published by Zetex Semiconductors plc.