

LEDC003 USER GUIDE

Performance:

- Color Temperature range: 2900K-8300K
- Viewing angle: 120°
- Maximum drive current: 350mA
- Thermal resistance: 5°C/W
- Max. junction temperature: 150°C
- Electrically neutral thermal path

The PCB construction is a single layer of printed copper. There is a solid aluminium backing for heat dissipation. The material used is Aismalibar Cobritherm™ [1] or similar, 1.5mm Al, 110µm dielectric and 35µm copper. It features 4 holes for M2.5 fixings if required.

Ordering Information

Order Number
LEDC003

The board is fitted with a male 6-pin input connector. This mates with any of the Diodes Zetex Evaluation boards which are fitted with a suitable socket. At the opposite end, a female connector is fitted, to allow multiple LED extensions as shown in the schematic below.

Description

This demonstration circuit consists of a simple connectable printed circuit board carrying a CREE® MX-6 lamp, a thermistor and switching links. It allows the evaluation and testing of attachable Zetex LED driver circuits with varying numbers of series connected LEDs.

A jumper link is used to allow connection of the LED as the NEXT or LAST in the chain. A further jumper link is provided to select whether the thermistor on the board is connected (position TH), or whether the connection is passed to a board further down the chain (PASSTH).

Further information can be obtained from:

<http://www.cree.com/products/pdf/XLampMX-6.pdf>

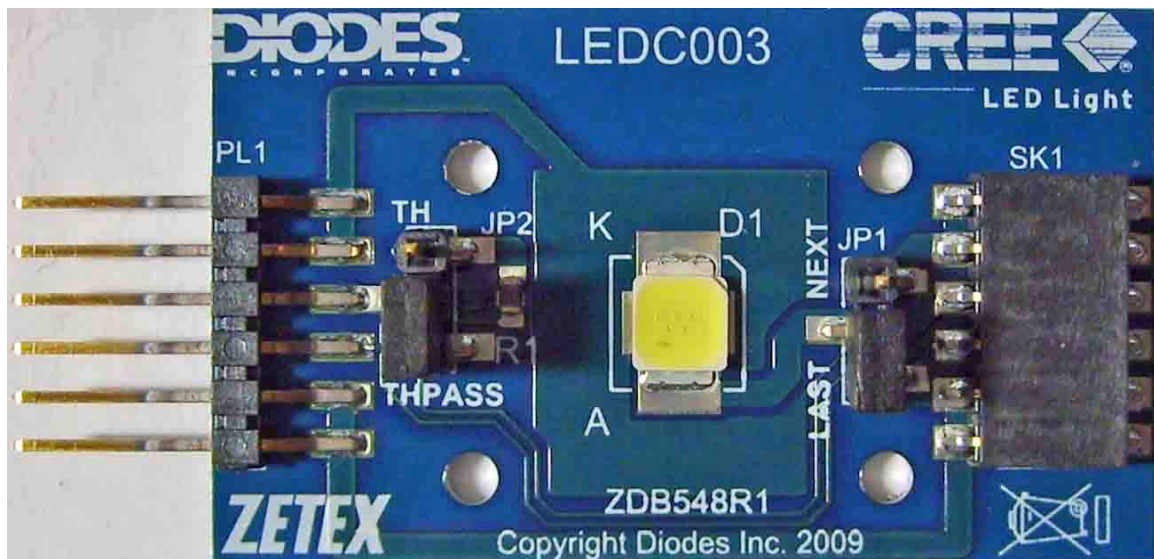

Schematic

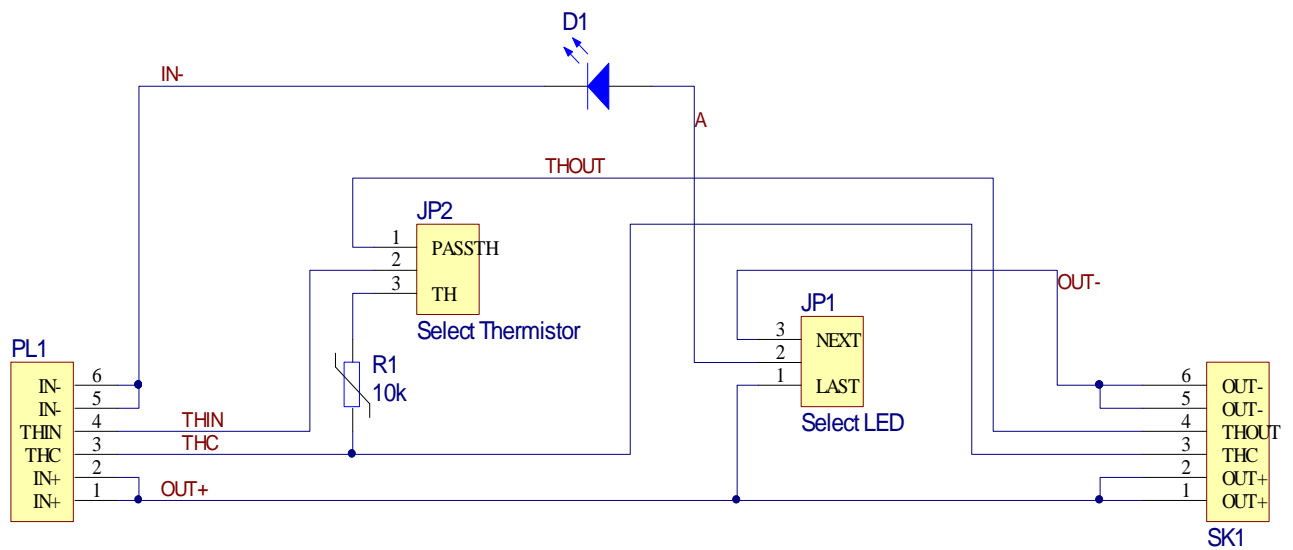

PCB Layout

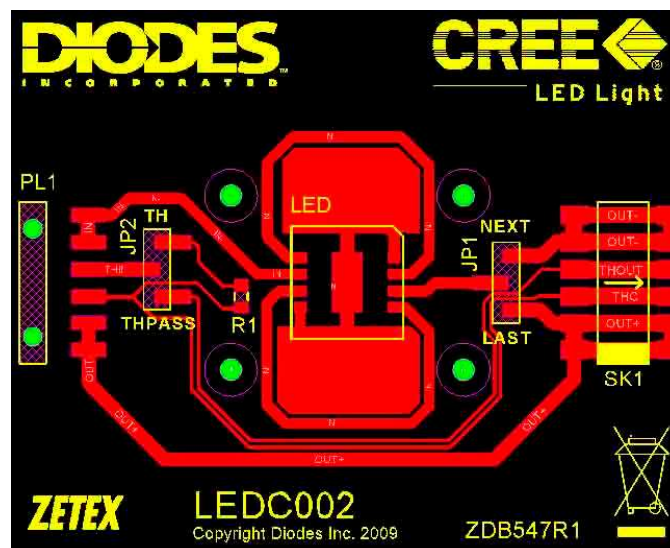

Top Side

USAGE

There are two circuits on the board: the LED circuit and the thermistor circuit.

The input (PL1) and output (SK1) connector pins 1+2 and 5+6 are used for the LED, and 4 and 5 are used for the thermistor.

LED circuit

If only one LED board is being used, or is the last in a chain of several boards, the jumper JP1 should be inserted in the 'LAST' position. This connects the LED directly across pins 1+2 and 5+6 of input connector PL1.

If several boards are being used in a chain, and the board concerned is not in the last position, the jumper JP1 should be inserted in the 'NEXT' position. This connects the LED in series between pins 5+6 on the input connector PL1 and pins 5+6 on the output connector SK1.

It is not possible to configure the board for multiple LEDs in parallel.

Thermistor circuit

In cases where the thermistor is not required, the position of JP2 is irrelevant but it should be removed if any other connections are made to pins 4 and 5 of PL1 or SK1.

If the thermistor is required, and only one LED board is being used, the jumper JP2 should be inserted in the 'TH' position. This connects the thermistor directly across pins 3 and 4 of the input connector PL1, thus making the thermistor 'active'.

If several boards are being used in a chain, the board on which the thermistor is required to be active should be set with JP2 in the 'TH' position. All the other boards should be set with JP2 in the 'THPASS' position. This disconnects the other thermistors and creates a direct link between pin 4 on the input connector PL1 and pin 4 on the output connector SK1. It is not possible to configure the board for multiple thermistors in parallel.

Parts List

Count	Designator	Description	Package	Manufacturer	Part Number
1	D1	Cree® MX-6 X-lamp®	-	Cree®	MX6AWT
1	R1	10kΩ Thermistor	0805	Vishay	2381 615
2	JP1, JP2	3- way headers for links	-	Samtec	TSM-103-02-L-SV

Input/ Output

Count	Designator	Description	Function	Manufacturer	Part Number
1	PL1	6 pin Input power connector (male) Horizontal header	Connection to LED driver or to previous LED demonstration board in series	Samtec	TSM-106-03-L-SH
1	SK1	Output connector (female)	Allows connection for new demonstration board to be added in series	Samtec	SSM-106-L-SH

Recommended Operating Conditions

Symbol	Parameter	Typ	Max	Units
V_F	Forward Voltage at $I_F = 300\text{mA}$	3.3	3.8	V
I_F	Forward current	-	350	mA

^[1] Cobritherm is a trademark of the Aismalibar Corporation

Cree is a registered trademark of Cree, Inc. Specifications given which relate to Cree® devices are provided in good faith, but may be changed without notice, and should be verified with Cree® before use.

IMPORTANT NOTICE

DIODES INCORPORATED MAKES NO WARRANTY OF ANY KIND, EXPRESS OR IMPLIED, WITH REGARD TO THIS DOCUMENT, INCLUDING, BUT NOT LIMITED TO, THE IMPLIED WARRANTIES OF MERCHANTABILITY AND FITNESS FOR A PARTICULAR PURPOSE (AND THEIR EQUIVALENTS UNDER THE LAWS OF ANY JURISDICTION).

Diodes Incorporated and its subsidiaries reserve the right to make modifications, enhancements, improvements, corrections or other changes without further notice to this document and any product described herein. Diodes Incorporated does not assume any liability arising out of the application or use of this document or any product described herein; neither does Diodes Incorporated convey any license under its patent or trademark rights, nor the rights of others. Any Customer or user of this document or products described herein in such applications shall assume all risks of such use and will agree to hold Diodes Incorporated and all the companies whose products are represented on Diodes Incorporated website, harmless against all damages.

Diodes Incorporated does not warrant or accept any liability whatsoever in respect of any products purchased through unauthorized sales channels.

Should Customers purchase or use Diodes Incorporated products for any unintended or unauthorized application, Customers shall indemnify and hold Diodes Incorporated and its representatives harmless against all claims, damages, expenses, and attorney fees arising out of, directly or indirectly, any claim of personal injury or death associated with such unintended or unauthorized application.

Products described herein may be covered by one or more United States, international or foreign patents pending. Product names and markings noted herein may also be covered by one or more United States, international or foreign trademarks.

LIFE SUPPORT

Diodes Incorporated products are specifically not authorized for use as critical components in life support devices or systems without the express written approval of the Chief Executive Officer of Diodes Incorporated. As used herein:

A. Life support devices or systems are devices or systems which:

1. are intended to implant into the body, or
2. support or sustain life and whose failure to perform when properly used in accordance with instructions for use provided in the labeling can be reasonably expected to result in significant injury to the user.

B. A critical component is any component in a life support device or system whose failure to perform can be reasonably be expected to cause the failure of the life support device or to affect its safety or effectiveness.

Customers represent that they have all necessary expertise in the safety and regulatory ramifications of their life support devices or systems, and acknowledge and agree that they are solely responsible for all legal, regulatory and safety-related requirements concerning their products and any use of Diodes Incorporated products in such safety-critical, life support devices or systems, notwithstanding any devices- or systems-related information or support that may be provided by Diodes Incorporated. Further, Customers must fully indemnify Diodes Incorporated and its representatives against any damages arising out of the use of Diodes Incorporated products in such safety-critical, life support devices or systems.

Copyright © 2009, Diodes Incorporated

www.diodes.com

Sales offices

The Americas

3050 E. Hillcrest Drive
Westlake Village,
CA 91362-3154
Tel: (+1) 805 446 4800
Fax: (+1) 805 446 4850

Europe

Kustermannpark
Balanstraße 59,
D-81541 München
Germany
Tel: (+49) 894 549 490
Fax: (+49) 894 549 4949

Taiwan

7F, No. 50,
Min Chuan Road
Hsin-Tien
Taipei, Taiwan
Tel: (+886) 289 146 000
Fax: (+886) 289 146 639

Shanghai

Rm. 606, No.1158
Changning Road
Shanghai, China
Tel: (+86) 215 241 4882
Fax (+86) 215 241 4891

Shenzhen

Room A1103-04,
ANLIAN Plaza, #4018
Jintian Road
Futian CBD,
Shenzhen, China
Tel: (+86) 755 882 849 88
Fax: (+86) 755 882 849 99

Korea

6 Floor, Changhwa B/D,
1005-5 Yeongtong-dong,
Yeongtong-gu, Suwon-si,
Gyeonggi-do, Korea 443-813
Tel: (+82) 312 731 884
Fax: (+82) 312 731 885